

ISSN 2076-0612 (print)
ISSN 2523-4617 (online)

MINISTRY OF EDUCATION AND SCIENCE OF UKRAINE

V.N. Karazin Kharkiv National University

МІНІСТЕРСТВО ОСВІТИ І НАУКИ УКРАЇНИ

Харківський національний університет імені В.Н. Каразіна

МИНИСТЕРСТВО ОБРАЗОВАНИЯ И НАУКИ УКРАИНЫ

Харьковский национальный университет имени В.Н. Каразина

PHOTOBIOLOGY AND PHOTOMEDICINE

**Фотобіологія та Фотомедицина
Фотобиология и Фотомедицина**

INTERNATIONAL SCIENTIFIC AND PRACTICAL JOURNAL

24 '2018

Published quarterly

Founded in 1998

Subscription index 49078

Kharkiv 2018

Approved for publication by the Academic Council of the V. N. Karazin Kharkiv National University
(March 28, 2018, Protocol No. 4)

The journal is a specialized publication in the fields of biological, medical, and technical sciences (Orders of Ministry of Education and Science of Ukraine: №515, 16.05.2016, №326, 04.04.2018 and №820, 11.07.2016)

Editor-in-Chief

Korobov A.M. V. N. Karazin Kharkiv National University, Kharkiv, Ukraine

Deputy Editor-in-Chief

Boyko V.V. SI "V.T. Zaitsev Institute of General and Emergency Surgery of NAMS of Ukraine", Kharkiv, Ukraine

Brill G.E. Saratov State Medical University named after V. I. Razumovskiy, Saratov, Russia

Tashyrev O.B. National Antarctic Scientific Center of Ministry of Education and Science of Ukraine, Kyiv, Ukraine

Responsible Secretaries

Chukhraev N.V. SMC "MedInTech", Kyiv, Ukraine

Rusanov K.V. Kharkiv, Ukraine

Utevsky A.Yu. V. N. Karazin Kharkiv National University, Kharkiv, Ukraine

Editorial Board

Anufrik S.S. Yanka Kupala State University of Grodno, Grodno, Belarus

Azarov O.D. Vinnytsia National Technical University, Vinnytsia, Ukraine

Babov K.D. SI "Ukrainian Research Institute of Medical Rehabilitation and Balneology", Odesa, Ukraine

Baybekov I.M. SI "Republican Specialized Center of Surgery named after academician V. Vakhidov", Tashkent, Uzbekistan

Baryakhtar V.G. National Technical University of Ukraine "Igor Sikorsky Kyiv Polytechnic Institute", Kyiv, Ukraine

Bobytsky Ya.V. University of Rzeszow, Rzeszow, Poland

Bogomolets O.V. Dr. Bogomolets Institute of Dermatology and Cosmetology, Kyiv, Ukraine

Boyko V.V. SI "Zaycev V.T. Institute of General and Urgent Surgery of NAMS of Ukraine", Kharkiv, Ukraine

Bozhkov A.I. V. N. Karazin Kharkiv National University, Kharkiv, Ukraine

Chervanov I.G. V. N. Karazin Kharkiv National University, Kharkiv, Ukraine

Dolia G.M. V. N. Karazin Kharkiv National University, Kharkiv, Ukraine

Dyomin O.O. Ministry of Foreign Affairs of Ukraine, Kyiv, Ukraine

Dubenko E.G. V. N. Karazin Kharkiv National University, Kharkiv, Ukraine

Gulyar S.A. A.A. Bogomolets Institute of Physiology of NASU, Kyiv, Ukraine

Ivanova Yu.V. SI "Zaycev V.T. Institute of General and Urgent Surgery of NAMS of Ukraine", Kharkiv, Ukraine

Henshel D. Indiana University Bloomington, Bloomington, USA

Kipensky A.V. National Technical University "Kharkiv Polytechnic Institute", Kharkiv, Ukraine

Klimova O.M. SI "Zaycev V.T. Institute of General and Urgent Surgery of NAMS of Ukraine", Kharkiv, Ukraine

Longo L. Institute of Laser Medicine, Italy

Lisichenko M.L. Kharkiv Petro Vasylenko National Technical University of Agriculture, Kharkiv, Ukraine

Maleev V.Ya. V. N. Karazin Kharkiv National University, Kharkiv, Ukraine

Minaev V.P. STA "IRE-Polyus" IPG Photonics, Fryazino, Russia

Nikolenko E.Ya. V. N. Karazin Kharkiv National University, Kharkiv, Ukraine

Oshyro T. Keio University, Oshiro Clinic, Japanese Medical Laser Laboratory, Minato-ku, Japan

Pavlov S.V. Vinnytsia National Technical University, Vinnytsia, Ukraine

Persky E.E. V. N. Karazin Kharkiv National University, Kharkiv, Ukraine

Popov M.M. Mechnikov Institute of Microbiology and Immunology of the NAMS of Ukraine, SI, Kyiv, Ukraine

Rochkind S. Neurosurgery Institute, Tel Aviv University, Israel

Rozumenko V.D. SI "Romodanov Neurosurgery Institute of NAMS of Ukraine", Kyiv, Ukraine

Rubinov A.N. B. I. Stepanov Institute of Physics, National Academy of Sciences of Belarus, Minsk, Belarus

Samoylova K.A. Institute of Cytology RAS, St. Petersburg, Russia

Shkorbatov Yu.G. V. N. Karazin Kharkiv National University, Kharkiv, Ukraine

Sokol E.I. National Technical University "Kharkiv Polytechnic Institute", Kharkiv, Ukraine

Stranadko E.F. State Scientific Center for Laser Medicine of the Ministry of Health of Russia, Moscow, Russia

Vasylyeva-

Linetska L.Ya. Kharkiv Medical Academy of Postgraduate Education, Kharkiv, Ukraine

Vladimirov Yu.A. Lomonosov Moscow State University, Moscow, Russia

Yabluchansky M.I. V. N. Karazin Kharkiv National University, Kharkiv, Ukraine

Yakimenko I.L. National University of Food Technologies, Kyiv, Ukraine

Zholtkevich G.M. V. N. Karazin Kharkiv National University, Kharkiv, Ukraine

Zhuravleva L.V. Kharkiv National Medical University, Kharkiv, Ukraine

Zlepko S.M. Vinnytsia National Technical University, Vinnytsia, Ukraine

Editorial office

Science and Research Laboratory of Quantum Biology and Quantum Medicine, V.N. Karazin Kharkiv National University

6 Svobody Sq., Kharkiv, 61022, Ukraine

Tel.: +38 (067) 731-14-31, +38 (057) 761-63-09; tel/fax: +38 (057) 707-51-91

E-mail: amkorobov@i.ua; amkorobov@karazin.ua

Web-site: www.fnjournal.univer.kharkov.ua

Articles were reviewed internally and externally

Certificate of State registration KB No.15473-4045 ПР, 29.07.2009

Затверджено до друку рішенням Вченої ради Харківського національного університету імені В.Н. Каразіна (протокол №4 від 28.03.2018)

Журнал є фаховим виданням у галузях біологічних, медичних та технічних наук (накази МОН України: №515 від 16.05.2016 р., №326 від 04.04.2018 р. та №820 від 11.07.2016 р.)

Головний редактор

Коробов А.М. Харківський національний університет імені В.Н. Каразіна, м. Харків, Україна

Заступники головного редактора

Бойко В.В. ДУ «Інститут загальної та невідкладної хірургії імені В.Т. Зайцева НАМН України», м. Харків, Україна

Брілль Г.С. Саратовський державний медичний університет імені В.І. Разумовського, м. Саратов, Росія

Ташіреєв О.Б. Національний антарктичний науковий центр МОН України, м. Київ, Україна

Відповідальні секретарі

Русанов К.В. м. Харків, Україна

Утєвський А.Ю. Харківський національний університет імені В.Н. Каразіна, м. Харків, Україна

Чухраєв М.В. НМЦ «МедІнТех», м. Київ, Україна

Редакційна колегія

Азаров О.Д. Вінницький національний технічний університет, м. Вінниця, Україна

Ануфрієв С.С. Гродненський державний університет імені Янки Купали, м. Гродно, Білорусь

Бабов К.Д. ДУ «Український науково-дослідний інститут медичної реабілітації та курортології», м. Одеса, Україна

Байбеков І.М. ДУ «Республіканський спеціалізований центр хірургії ім. акад. В. Вахідова», м. Ташкент, Узбекистан

Бар'яхтар В.Г. Національний технічний університет України «Київський політехнічний інститут імені Ігоря Сікорського», м. Київ, Україна

Бобицький Я.В. Університет Жешува, м. Жешув, Польща

Богомолець О.В. Інститут дерматології та косметології доктора Богомолець, м. Київ, Україна

Божков А.І. Харківський національний університет імені В. Н. Каразіна, м. Харків, Україна

Бойко В.В. ДУ «Інститут загальної та невідкладної хірургії імені В.Т.Зайцева НАМН України», м. Харків, Україна

Васильєва-

Лінецька Л.Я. Харківська медична академія післядипломної освіти, м. Харків, Україна

Владимиров Ю.А. Московський державний університет імені М.В. Ломоносова, м. Москва, Росія

Гуляр С.О. Інститут фізіології імені Богомольця НАН України, м. Київ, Україна

Доля Г.М. Харківський національний університет імені В. Н. Каразіна, м. Харків, Україна

Дубенко Є.Г. Харківський національний університет імені В. Н. Каразіна, м. Харків, Україна

Дьомін О.О. Міністерство закордонних справ України, м. Київ, Україна

Жолткевич Г.М. Харківський національний університет імені В. Н. Каразіна, м. Харків, Україна

Журавльова Л.В. Харківський національний медичний університет, м. Харків, Україна

Злепко С.М. Вінницький національний технічний університет, м. Вінниця, Україна

Іванова Ю.В. ДУ «Інститут загальної та невідкладної хірургії імені В.Т. Зайцева НАМН України», м. Харків, Україна

Кіпенський А.В. Національний технічний університет «Харківський політехнічний інститут», м. Харків, Україна

Клімова О.М. ДУ «Інститут загальної та невідкладної хірургії імені В.Т. Зайцева НАМН України», м. Харків, Україна

Лисиченко М.Л. Харківський національний технічний університет сільського господарства імені Петра Василенка, м. Харків, Україна

Лонго Л. Інститут лазерної медицини, Італія

Малеєв В.Я. Харківський національний університет імені В. Н. Каразіна, м. Харків, Україна

Мінаєв В.П. НТО «ІРЕ-Полюс», IPG Photonics, м. Фрязіно, Росія

Ніколенко Є.Я. Харківський національний університет імені В. Н. Каразіна, м. Харків, Україна

Ошіро Т. Університет Кейо, Клініка Ошіро, Японська медична лазерна лабораторія, м. Мінато-ку, Японія

Павлов С.В. Вінницький національний технічний університет, м. Вінниця, Україна

Перський Є.Е. Харківський національний університет імені В. Н. Каразіна, м. Харків, Україна

Попов М.М. ДУ «Інститут мікробіології та імунології імені І.І.Мечникова НАМН України», м. Київ, Україна

Розуменко В.Д. ДУ «Інститут нейрохірургії імені Ромоданова НАМН України», м. Київ, Україна

Рочкінд С. Інститут нейрохірургії, Тель-Авівський університет, Ізраїль

Рубінов А.М. Інститут фізики імені Б.І. Степанова Національної академії наук Білорусі, м. Мінськ, Білорусь

Самойлова К.О. Інститут цитології РАН, м. Санкт-Петербург, Росія

Сокол Є.І. Національний технічний університет «Харківський політехнічний інститут», м. Харків, Україна

Странадко Є.Ф. Державний науковий центр лазерної медицини Міністерства охорони здоров'я Росії, м. Москва, Росія

Хеншель Д. Університет Індіани, м. Блумінгтон, США

Черваньов І.Г. Харківський національний університет імені В. Н. Каразіна, м. Харків, Україна

Шкорбатов Ю.Г. Харківський національний університет імені В. Н. Каразіна, м. Харків, Україна

Яблчанський М.І. Харківський національний університет імені В. Н. Каразіна, м. Харків, Україна

Якименко І.Л. Національний університет харчових технологій, м. Київ, Україна

Редакція

Науково-дослідна лабораторія квантової біології та квантової медицини

Харківський національний університет імені В. Н. Каразіна

Майдан Свободи, 6, м. Харків, 61022, Україна

Тел.: +38 (067) 731-14-31, +38 (057) 761-63-09; тел./факс: +38 (057) 707-51-91

E-mail: amkorobov@i.ua; amkorobov@karazin.ua

Web-site: www.fnfjournal.univer.kharkov.ua

Статті пройшли внутрішнє та зовнішнє рецензування

Свідоцтво про державну реєстрацію KB № 15473-4045 ПР від 29.07.2009

Утверждено в печать решением Ученого совета Харьковского национального университета имени В.Н. Каразина (протокол № 4 от 28.03.2018)

Журнал является специализированным изданием в областях биологических, медицинских и технических наук (приказы МОН Украины: № 515 от 16.05.2016 г., № 326 от 04.04.2018 г. и № 820 от 11.07.2016 г.)

Главный редактор

Коробов А.М. Харьковский национальный университет имени В.Н. Каразина, г. Харьков, Украина

Заместители главного редактора

Бойко В.В. ГУ «Институт общей и неотложной хирургии имени В.Т. Зайцева НАМН Украины», г. Харьков, Украина

Брилль Г.Е. Саратовский государственный медицинский университет имени В.И.Разумовского, г. Саратов, Россия

Таширев А.Б. Национальный антарктический научный центр МОН Украины, г. Киев, Украина

Ответственные секретари

Русанов К.В. г. Харьков, Украина

Утевский А.Ю. Харьковский национальный университет имени В.Н. Каразина, г. Харьков, Украина

Чухраев Н.В. НМЦ «МедИнТех», г. Киев, Украина

Редакционная коллегия

Азаров А.Д. Винницкий национальный технический университет, г. Винница, Украина

Ануфрик С.С. Гродненский государственный университет имени Янки Купалы, г. Гродно, Беларусь

Бабов К.Д. ГУ «Украинский научно-исследовательский институт медицинской реабилитации и курортологии», г. Одесса, Украина

Байбеков И.М. ГУ «Республиканский специализированный центр хирургии им. акад. В.Вахидова», г. Ташкент, Узбекистан

Барьяхтар В.Г. Национальный технический университет Украины «Киевский политехнический институт имени Игоря Сикорского», г. Киев, Украина

Бобыцкий Я.В. Университет Жешува, г. Жешув, Польша

Богомолец О.В. Институт дерматологии и косметологии доктора Богомолец, г. Киев, Украина

Божков А.И. Харьковский национальный университет имени В.Н.Каразина, г. Харьков, Украина

Бойко В.В. ГУ «Институт общей и неотложной хирургии имени В.Т. Зайцева НАМН Украины», г. Харьков, Украина

Васильева-Линецкая Л.Я. Харьковская медицинская академия последипломного образования, г. Харьков, Украина

Владимиров Ю.А. Московский государственный университет имени М.В. Ломоносова, г. Москва, Россия

Гуляр С.А. Институт физиологии имени Богомольца НАН Украины, г. Киев, Украина

Демин О.А. Министерство иностранных дел Украины, г. Киев, Украина

Доля Г.Н. Харьковский национальный университет имени В.Н. Каразина, г. Харьков, Украина

Дубенко Е.Г. Харьковский национальный университет имени В.Н. Каразина, г. Харьков, Украина

Жолткевич Г.Н. Харьковский национальный университет имени В.Н. Каразина, г. Харьков, Украина

Журавлева Л.В. Харьковский национальный медицинский университет, г. Харьков, Украина

Злепко С.М. Винницкий национальный технический университет, г. Винница, Украина

Иванова Ю.В. ГУ «Институт общей и неотложной хирургии имени В.Т.Зайцева НАМН Украины», г. Харьков, Украина

Кипенский А.В. Национальный технический университет «Харьковский политехнический институт», г. Харьков, Украина

Климова Е.М. ГУ «Институт общей и неотложной хирургии имени В.Т. Зайцева НАМН Украины», г. Харьков, Украина

Лисиченко Н.Л. Харьковский национальный технический университет сельского хозяйства имени Петра Василенко, г. Харьков, Украина

Лонго Л. Институт лазерной медицины, Италия

Малеев В.Я. Харьковский национальный университет имени В.Н. Каразина, г. Харьков, Украина

Минаев В.П. НТО «ИРЭ-Полус», IPG Photonics г. Фрязино, Россия

Николенко Е.Я. Харьковский национальный университет имени В.Н. Каразина, г. Харьков, Украина

Оширо Т. Университет Кейо, Клиника Оширо, Японская медицинская лазерная лаборатория, г. Минато-ку, Япония

Павлов С.В. Винницкий национальный технический университет, г. Винница, Украина

Перский Е.Э. Харьковский национальный университет имени В.Н. Каразина, г. Харьков, Украина

Попов Н.Н. ГУ «Институт микробиологии и иммунологии имени И.И. Мечникова НАМН Украины», г. Киев, Украина

Розуменко В.Д. ГУ «Институт нейрохирургии имени Ромоданова НАМН Украины», г. Киев, Украина

Рочкинд С. Институт нейрохирургии, Тель-Авивский университет, Израиль

Рубинов А.Н. Институт физики имени Б.И. Степанова Национальной академии наук Беларуси, г. Минск, Беларусь

Самойлова К.А. Институт цитологии РАН, г. Санкт-Петербург, Россия

Сокол Е.И. Национальный технический университет «Харьковский политехнический институт», г. Харьков, Украина

Странадоко Е.Ф. Государственный научный центр лазерной медицины Министерства здравоохранения России, г. Москва, Россия

Хеншель Д. Университет Индианы, г. Блумингтон, США

Черванев И.Г. Харьковский национальный университет имени В.Н. Каразина, г. Харьков, Украина

Шкорбатов Ю.Г. Харьковский национальный университет имени В.Н. Каразина, г. Харьков, Украина

Яблунчанский Н.И. Харьковский национальный университет имени В.Н. Каразина, г. Харьков, Украина

Якименко И.Л. Национальный университет пищевых технологий, г. Киев, Украина

Редакция

Научно-исследовательская лаборатория квантовой биологии и квантовой медицины

Харьковский национальный университет имени В.Н. Каразина

Майдан Свободы, 6, г. Харьков, 61022, Украина

Тел.: +38 (067) 731-14-31, +38 (057) 761-63-09; тел./факс: +38 (057) 707-51-91

E-mail: amkorobov@i.ua; amkorobov@karazin.ua

Web-site: www.fnjournal.univer.kharkov.ua

Статьи прошли внутреннее и внешнее рецензирование

Свидетельство о государственной регистрации КВ № 15473-4045 ПР от 29.07.2009

© Харьковский национальный университет имени В.Н. Каразина, 2018

CONTENTS

CLINICAL PHOTOMEDICINE

IINNOVATIVE LASER TECHNOLOGIES IN BRAIN TUMORS SURGERY <i>V.D. Rozumenko</i>	9
PHOTOTHERAPY IN COMPLEX TREATMENT OF WOUNDS IN PATIENTS WITH ISCHEMIC AND NEUROISCHEMIC FORM OF DIABETIC SYNDROME <i>Yu.V. Ivanova, E.M. Klimova, V.A. Prasol, E.V. Mushenko, A.M. Korobov, M.V. Pogorielov, D.S. Timchenko, M.E. Serbin, D.O. Kirienko</i>	13
MAIN STAGES OF DEVELOPMENT AND MODERN-STATE-OF-ART OF PHOTODYNAMIC THERAPY IN RUSSIA <i>E.Ph. Stranadko, T.I. Malova</i>	21
MATERIALS TO THE HISTORY OF KHARKOV CLINIC ESTABLISHED BY DOCTOR G.A. DAVIDOVICH (1895–1920) <i>K.V. Rusanov, E.G. Rusanova</i>	28

PHOTOBIOLOGY AND EXPERIMENTAL PHOTOMEDICINE

MUTATIONS RATE IN DIFFERENT LINES OF <i>DROSOPHILA MELANOGASTER</i> AFTER THE TREATMENT WITH CAFFEINE AND HE-NE LASER RADIATION <i>O.V. Gorenskaya, N.S. Filiponenko, Yu.G. Shckorbatov</i>	41
MORPHOLOGICAL SUBSTANTIATION OF THE USE OF LASER AND LED IRRADIATION IN EMERGENT TREATMENT OF ULCER COMPLICATIONS <i>I.M. Baybekov, D.T. Pulatov</i>	46
ACCENTS OF THE HUMAN BODY ELECTROMAGNETIC BALANCE REGULATION SYSTEM <i>S.A. Gulyar</i>	52
THERMAL PROCESSES IN HUMAN SKIN UPON IRRADIATION BY LASER PULSES <i>N.G. Kokodii, V.A. Timaniuk, A.M. Korobov</i>	69

PHYSICS AND ENGINEERING IN PHOTOBIOLOGY AND PHOTOMEDICINE

PHOTOTHERAPEUTIC HARDWARE COMPLEX FOR REHABILITATION, PREVENTION AND TREATMENT OF DISEASES OF THE HUMAN CENTRAL NERVOUS SYSTEM <i>A.M. Korobov, M.F. Posokhov, V.A. Korobov, O.V. Kozyr</i>	75
---	----

INFORMATION

INSTRUCTIONS TO AUTHORS	86
--------------------------------	----

ЗМІСТ

КЛІНІЧНА ФОТОМЕДИЦИНА

ІННОВАЦІЙНІ ЛАЗЕРНІ ТЕХНОЛОГІЇ В ХІРУРГІЇ ПУХЛИН ГОЛОВНОГО МОЗКУ <i>В.Д. Розуменко</i>	9
ФОТОТЕРАПІЯ В КОМПЛЕКСІ ЛІКУВАННЯ ПРИ ПЛАСТИЧНОМУ ЗАКРИТТІ РАН У ХВОРИХ З ІШЕМІЧНОЮ ТА НЕЙРОІШЕМІЧНОЮ ФОРМАМИ СТОПИ ДІАБЕТИКА <i>Ю.В. Іванова, О.М. Клімова, В.О. Прасол, Є.В. Мушенко, А.М. Коробов, М.В. Погорелов, Д.С. Тімченко, М.Є. Сербін, Д.О. Кірієнко</i>	13
ОСНОВНІ ЕТАПИ РОЗВИТКУ ТА СУЧАСНИЙ СТАН ФОТОДИНАМІЧНОЇ ТЕРАПІЇ В РОСІЇ <i>Є.Ф. Странадко, Т.І. Малова</i>	21
МАТЕРІАЛИ ДО ІСТОРІЇ ХАРКІВСЬКОЇ ЛІКАРНІ, ЗАСНОВАНОЇ ЛІКАРЕМ Г.А. ДАВИДОВИЧЕМ (1895-1920 рр.) <i>К.В. Русанов, Є.Г. Русанова</i>	28
ФОТОБІОЛОГІЯ ТА ЕКСПЕРИМЕНТАЛЬНА ФОТОМЕДИЦИНА	
ОСОБЛИВОСТІ МУТАЦІЙНОГО ПРОЦЕСУ У РІЗНИХ ЛІНІЙ <i>DROSOPHILA MELANOGASTER</i> ЗА УМОВ СПІЛЬНОЇ ДІЇ КОФЕЇНУ І ВИПРОМІНЮВАННЯ НЕ-НЕ ЛАЗЕРУ <i>О.В. Горенська, Н.С. Філіпоненко, Ю.Г. Шкорбатов</i>	41
МОРФОЛОГІЧНЕ ОБҐРУНТУВАННЯ ВИКОРИСТАННЯ ЛАЗЕРНОГО ТА СВІТЛОДІОДНОГО ВИПРОМІНЮВАННЯ В ЛІКУВАННІ УРГЕНТНИХ УСКЛАДНЕНЬ ВИРАЗКОВОЇ ХВОРОБИ <i>І.М. Байбеков, Д.Т. Пулатов</i>	46
АКЦЕНТИ СИСТЕМИ РЕГУЛЮВАННЯ ЕЛЕКТРОМАГНІТНОГО БАЛАНСУ ОРГАНІЗМУ ЛЮДИНИ <i>С.О. Гуляр</i>	52
ТЕПЛОВІ ПРОЦЕСИ В ШКІРІ ЛЮДИНИ ПІД ЧАС ОПРОМІНЕННЯ ЛАЗЕРНИМИ ІМПУЛЬСАМИ <i>М.Г. Кокодій, В.О. Тіманюк, А.М. Коробов</i>	69
ФІЗИКО-ТЕХНІЧНІ ОСНОВИ ФОТОБІОЛОГІЇ ТА ФОТОМЕДИЦИНИ	
ФОТОТЕРАПЕВТИЧНИЙ АПАРАТНИЙ КОМПЛЕКС ДЛЯ РЕАБІЛІТАЦІЇ, ПРОФІЛАКТИКИ ТА ЛІКУВАННЯ ЗАХВОРЮВАНЬ ЦЕНТРАЛЬНОЇ НЕРВОВОЇ СИСТЕМИ ЛЮДИНИ <i>А.М. Коробов, М.Ф. Посохов, В.А. Коробов, О.В. Козир</i>	75
ІНФОРМАЦІЯ	
ІНСТРУКЦІЯ ДЛЯ АВТОРІВ	86

СОДЕРЖАНИЕ

КЛИНИЧЕСКАЯ ФОТОМЕДИЦИНА

ИННОВАЦИОННЫЕ ЛАЗЕРНЫЕ ТЕХНОЛОГИИ В ХИРУРГИИ ОПУХОЛЕЙ ГОЛОВНОГО МОЗГА <i>В.Д. Розуменко</i>	9
ФОТОТЕРАПИЯ В КОМПЛЕКСЕ ЛЕЧЕНИЯ ПРИ ПЛАСТИЧЕСКОМ ЗАКРЫТИИ РАН У БОЛЬНЫХ С ИШЕМИЧЕСКОЙ И НЕЙРОИШЕМИЧЕСКОЙ ФОРМАМИ СТОПЫ ДИАБЕТИКА <i>Ю.В. Иванова, Е.М. Климова, В.А. Прасол, Е.В. Мушенко, А.М. Коробов, М.В. Погорелов, Д.С. Тимченко, М.Е. Сербин, Д.А. Кириенко</i>	13
ОСНОВНЫЕ ЭТАПЫ РАЗВИТИЯ И СОВРЕМЕННОЕ СОСТОЯНИЕ ФОТОДИНАМИЧЕСКОЙ ТЕРАПИИ В РОССИИ <i>Е.Ф. Странадко, Т.И. Малова</i>	21
МАТЕРИАЛЫ К ИСТОРИИ ХАРЬКОВСКОЙ ЛЕЧЕБНИЦЫ, УЧРЕЖДЕННОЙ ВРАЧОМ Г.А. ДАВИДОВИЧЕМ (1895–1920 гг.) <i>К.В. Русанов, Е.Г. Русанова.</i>	28
ФОТОБІОЛОГІЯ І ЕКСПЕРИМЕНТАЛЬНА ФОТОМЕДИЦИНА	
ОСОБЕННОСТИ МУТАЦИОННОГО ПРОЦЕССА У РАЗЛИЧНЫХ ЛИНИЙ <i>DROSOPHILA MELANOGASTER</i> ПРИ КОМБИНИРОВАННОМ ДЕЙСТВИИ КОФЕИНА И ИЗЛУЧЕНИЯ НЕ-НЕ ЛАЗЕРА <i>О.В. Горенская, Н.С. Филипоненко, Ю.Г. Шкорбатов</i>	41
МОРФОЛОГИЧЕСКОЕ ОБОСНОВАНИЕ ИСПОЛЬЗОВАНИЯ ЛАЗЕРНОГО И СВЕТОДИОДНОГО ИЗЛУЧЕНИЯ В ЛЕЧЕНИИ УРГЕНТНЫХ ОСЛОЖНЕНИЙ ЯЗВЕННОЙ БОЛЕЗНИ <i>И.М. Байбеков, Д.Т. Пулатов</i>	46
АКЦЕНТЫ СИСТЕМЫ РЕГУЛЯЦИИ ЭЛЕКТРОМАГНITНОГО БАЛАНСА ОРГАНИЗМА ЧЕЛОВЕКА <i>С.А. Гуляр</i>	52
ТЕПЛОВЫЕ ПРОЦЕССЫ В КОЖЕ ЧЕЛОВЕКА ПРИ ОБЛУЧЕНИИ ЛАЗЕРНЫМИ ИМПУЛЬСАМИ <i>Н.Г. Кокодий, В.А. Тиманюк, А.М. Коробов</i>	69
ФІЗИКО-ТЕХНІЧЕСКІЕ ОСНОВИ ФОТОБІОЛОГІЇ І ФОТОМЕДИЦИНИ	
ФОТОТЕРАПЕВТИЧЕСКИЙ АППАРАТНЫЙ КОМПЛЕКС ДЛЯ РЕАБИЛИТАЦИИ, ПРОФИЛАКТИКИ И ЛЕЧЕНИЯ ЗАБОЛЕВАНИЙ ЦЕНТРАЛЬНОЙ НЕРВНОЙ СИСТЕМЫ ЧЕЛОВЕКА <i>А.М. Коробов, Н.Ф. Посохов, В.А. Коробов, Е.В. Козырь</i>	75
ІНФОРМАЦІЯ	
ІНСТРУКЦІЯ ДЛЯ АВТОРОВ	86



CLINICAL PHOTOMEDICINE

PHOTOBIOLOGY AND EXPERIMENTAL
PHOTOMEDICINE

PHYSICS AND ENGINEERING IN PHOTOBIOLOGY
AND PHOTOMEDICINE

IINNOVATIVE LASER TECHNOLOGIES IN BRAIN TUMORS SURGERY
V.D. Rozumenko

● **PHOTOTHERAPY IN COMPLEX TREATMENT OF WOUNDS IN PATIENTS
WITH ISCHEMIC AND NEUROISCHEMIC FORM OF DIABETIC SYNDROME**
*Yu.V. Ivanova, E.M. Klimova, V.A. Prasol, E.V. Mushenko, A.M. Korobov,
M.V. Pogorelov, D.S. Timchenko, M.E. Serbin, D.O. Kirienco*

● **MAIN STAGES OF DEVELOPMENT AND MODERN-STATE-OF-ART
OF PHOTODYNAMIC THERAPY IN RUSSIA**
E.Ph. Stranadko, T.I. Malova

● **MATERIALS TO THE HISTORY OF KHARKOV CLINIC ESTABLISHED
BY DOCTOR G.A. DAVIDOVICH (1895–1920)**
K.V. Rusanov, E.G. Rusanova

●

INNOVATIVE LASER TECHNOLOGIES IN BRAIN TUMORS SURGERY

V.D. Rozumenko

*Prof., Dr. Sci. (Med.), Head of the clinic
Clinic of Intracerebral Tumors
SI "Romodanov Neurosurgery Institute of NAMS of Ukraine"
32 Platona Mayborody St., Kyiv, 04050, Ukraine
tel/fax: +38 (044) 483-92-19
e-mail: rozumenko.neuro@gmail.com
ORCID 0000-0002-8774-6942*

The article presents the results of application of innovative laser technologies in the surgical treatment of brain tumors. The article reviews the problems of a differentiated approach to the choice of the laser source as well as optimization of intraoperative application of laser dissection effects, vaporization, coagulation and thermal destruction of tumor tissue, providing increase of surgery efficiency degree and patients' quality of life. The results of studies on the development of laser surgery planning method and intraoperative navigation maintenance for brain tumors laser surgery method are presented.

Key words: brain tumors, laser technologies, neuronavigation.

ІННОВАЦІЙНІ ЛАЗЕРНІ ТЕХНОЛОГІЇ В ХІРУРГІЇ ПУХЛИН ГОЛОВНОГО МОЗКУ

В.Д. Розуменко

ДУ «Інститут нейрохірургії ім. акад. А.П. Ромоданова НАМН України», м. Київ, Україна

У статті представлені результати застосування інноваційних лазерних технологій при хірургічному лікуванні пухлин головного мозку. У статті розглядаються проблеми диференційованого підходу до вибору лазерного випромінювача, а також оптимізація інтраопераційного застосування ефектів лазерного розтину, випаровування, коагуляції та термічного руйнування пухлинної тканини, що забезпечує підвищення ступеня ефективності хірургії та якості життя пацієнтів. Наведено результати досліджень щодо розробки методу планування лазерної хірургії та інтраопераційного навігаційного обслуговування методу лазерної хірургії пухлин головного мозку.

Ключові слова: пухлини мозку, лазерні технології, нейронавігація.

ИННОВАЦИОННЫЕ ЛАЗЕРНЫЕ ТЕХНОЛОГИИ В ХИРУРГИИ ОПУХОЛЕЙ ГОЛОВНОГО МОЗГА

В.Д. Розуменко

ГУ «Институт нейрохирургии им. акад. А.П. Ромоданова НАМН Украины», г. Киев, Украина

В статье представлены результаты применения инновационных лазерных технологий в хирургическом лечении опухолей головного мозга. В статье рассматриваются проблемы дифференцированного подхода к выбору лазерного излучателя, а также оптимизация интраоперационного применения эффектов лазерного рассеечения, испарения, коагуляции и термической деструкции опухолевой ткани, что позволяет повысить эффективность операции и качество жизни пациентов. Представлены результаты исследований по разработке метода планирования лазерной хирургии и интраоперационного навигационного обслуживания метода лазерной хирургии опухолей головного мозга.

Ключевые слова: опухоли головного мозга, лазерные технологии, нейронавигация.

Introduction

The problem of brain tumors surgical treatment is one of the most pressing in modern oncology. The incidence rate of primary benign and malignant brain tumors in industrialized countries is more than 14 cases per 100 thousand people. Metastatic (secondary) brain tumors are being diagnosed in 3–4 times more frequently. The number of brain metastatic tumors increases significantly every year, due to the wide-

spread growth of cancer pathology as a whole. [1] Annually, neurosurgical clinics of Ukraine carry out up to 5000 surgeries for brain tumors. The efficiency of therapeutic interventions in neoplastic brain lesion is defined by the level of applied range of advanced technical means of early highly informative diagnosis and innovative surgical techniques. Such modern methods of neuroimaging diagnostics, as X-ray computed tomography (CT), magnetic resonance imaging

(MRI), positron emission tomography (PET), single photon emission computed tomography (SPECT), allow revealing the tumor brain lesion in the early disease stages, and thus define the appropriate range of therapeutic means of influence on tumor process, providing the treatment efficacy, quality of life and patients life expectancy increase. The key to successful surgical treatment of patients with brain tumors is application of modern microsurgical techniques of tumor removal, neuronavigation, ultrasound and endoscopic techniques. The brand new high level of brain tumors surgery is achieved by laser technologies application. [2-8]

Materials and methods

With the use of surgical laser technology, 660 surgeries for removal of intracerebral and extracerebral brain tumors have been conducted at the SI "Romodanov Neurosurgery Institute, National Academy of Medical Sciences of Ukraine". We have our own experience in clinical application of surgical laser devices of domestic and foreign production, and this allowed the development of innovative technologies for surgical treatment of brain tumors of various sites, histological structure and grade. To remove the brain tumors, we applied the following devices: "Sayany MT" carbon dioxide laser device (emission wavelength of 10.6 micrometers), "Raduga-1" neodymium-YAG laser device (emission wavelength of 1.06 microns), COHERENT "Versa Pulse Select" holmium-YAG laser (emission wavelength of 2.1 micron), "Lika-khirurg" (wavelength 0.808 micron) and "Lika-khirurg M" (wavelength 1.47 microns) semiconductor laser devices.

Preoperative examination included performance of X-ray computed tomography, magnetic resonance imaging, functional magnetic resonance imaging, magnetic resonance angiography, magnetic resonance tractography, single photon emission computed tomography. Comprehensive assessment of the imaging studies findings allow the tumor process verification and obtaining of the diagnostic information about the topography, size, tumor growth areas characteristics, lesions of the surrounding anatomical structures and borderline functionally important and vital brain structures, to identify the main sources tumor blood supply, to determine the degree of tumor vascularization, to establish the presence of cystic component, necrotic changes sites, and foci of intra-tumor hemorrhage.

Currently, the clinic of neuro-oncology Institute of Neurosurgery performs laser brain tumors microsurgery with intraoperative application of "StealthStation TREON Rlus" neuronavigation station (Medtronic, USA), which is equipped with a telemonitoring system in real time mode, which allows for control and correction of all stages of laser-surgical effects on tumor. [1,9] In application of surgical navigation, the results of neuroimaging studies were integrated into the navigation system and spatial modeling of 3D relief of cere-

bral hemispheres surface, brain convolutions and sulci cerebri was performed, anatomical and topographical tumor relationship to the surrounding brain structures, main arteries, venous basin, brain ventricular system was determined, stereotactic calculations and tracing for the best transcortical surgical access to the tumor, tumor segmentation and contouring, as well as the choice of the laser irradiation area was performed. Subsequently, we determined the optimum extent of planned surgical intervention and differentiated use of laser technology, using the developed laser microsurgery techniques and methods of laser tumor removal.

Results and discussion

In laser-surgical brain tumors removal the following methods are used: method of tumor tissue laser incision and excision, method of laser photocoagulation with devascularization of hypervascularized tumor areas, method of layer-by-layer laser vaporization of small tumor parts in there expansion to the functionally important and vital brain areas, method of laser thermal destruction of invasive expanding tumor fragments. The destructive effect of the tumor tissue exposure to high-energy laser radiation is confirmed by morphological studies, including electron microscopy findings. [10-15] Modulating the laser parameters enables achievement of the intended effect of ablative influence on the tumor tissue, providing the surgery efficiency due to the cyto-reduction. At that, it is necessary to apply the differentiated approach to laser radiation of different wavelength, of lasing regime, of radiation power and power density. To remove the tumor tissue using a laser vaporization method, the most appropriate way is to use the infrared carbon dioxide laser, the defocused beam of which allows performance of visually controlled layer-by-layer tumor tissue "evaporation", and this eliminates the factor of traction mechanical effect on adjacent brain structures. Infrared YAG-neodymium laser radiation has good coagulation properties, ensuring the effect of tumor tissue devascularization. Therefore, exposure of hypervascularized tumor areas to the radiation of YAG-Neodymium laser leads to coagulation of newly formed abnormal tumor vessels, resulting in their thrombosing, and then the tumor tissue becomes "bloodless", its size decreases (shrinks), and tumor cells "die" due to hyperthermia. Application of laser destruction method eliminates the need for tumor resection and surgical ablation of tumor tissue fragments directly in functionally important and vital brain areas, intraoperative traumatization of which is associated with the risk of postoperative persistent neurological deficit. YAG-holmium laser radiation allows performance of segmental excision and removal of calcified and ossified high-density tumor tissues. Currently, to remove the tumors of functionally significant speech-motor brain areas, as well as tumors that spread to the vital median brain formations, we use the "Lika-Khirurg" (214 surgeries performed) and

“Lika-KhirurgM” (37 surgeries performed) semiconductor surgical laser devices; at high power density, their radiation provides tumor tissue dissection and vaporization, and when the density is lowered, the effect of laser photocoagulation and laser thermal destruction is achieved. For the removal of tumors, which spread to the “critical” functionally significant (mainly speech-motor areas) and vital (median) brain parts, the laser stage of surgery is performed under control of neuronavigation, which ensures a high degree of laser radiation accuracy in exposure of the tumor tissue within the tumor “node”, without damaging the adjacent brain structures. The final stage of the surgery with application of the defocused laser irradiation includes performance of thermal destruction of tumor infiltration areas of the resected tumor bed walls.

We have developed an innovative method of brain tumors removal with laser, applied together with the multimodal neuronavigation in real time mode, and this allows exposure of the tumor tissue to the laser thermal effect. And imaging of this tissue on the screen is provided due to the computerized integration of MRI, MSCT and SPECT images into the navigation station. The virtual 3D planning of laser surgery is performed at the preoperative stage, when we determine the areas for laser irradiation and adjacent topography of the brain structures, main arterial vessels, and venous basins. [9,16] Thus, using the neuronavigation based on the results of CT, MRI, functional MRI, MR-tractography, MR-venography and SPECT studies surgical access to the tumor and the laser radiation path are planned. In the process of laser-surgical tumor removal, the data of virtual 3D planning of the surgery are directly compared to the image of the surgical area in real time mode, and this allows not only to perform the navigation control of all surgery stages, but also to perform the intraoperative navigation verification of the removed tumor tissue extent.

Conclusion

Laser surgery of brain tumors is a progressive method of modern neurooncology. The brand new highly effective methods of brain tumors removal have been developed, using the laser technologies. Application of innovative laser-surgical methods of brain tumors removal, based on a differentiated use of high-energy laser radiation of different wavelengths and power density, allows reduction of the surgery risks and increasing the surgery efficiency degree, providing the high quality of life for patients, who underwent surgery. Together with multimodal neuronavigation, the method of laser thermal destruction of brain tumors, used in removing of tumors in functionally important and vital brain parts, enables intraoperative orientation in topographic relationship of tumor to the surrounding anatomical structures, and thus the accuracy of tumor tissue exposure to laser is improves and laser

surgical procedures safety is provided. New opportunities of laser surgery in intracerebral malignant tumors are available due to the intraoperative application of fluorescent tumor imaging method with application of 5-aminolevulinic acid; this allows identification of tumor tissue expansion and performance of tumor laser irradiation and thermal destruction, preserving the anatomical and functional integrity of the adjacent brain structures. [5,17] A promising method of laser radiation application in the deep intracerebral tumors is the development of endoscopic navigation controlled laser interstitial thermal therapy method. [11,16,18-20] A combined performance of thermal destruction and photodynamic therapy may be considered, as a highly efficient method of increasing the surgery efficiency in infiltrative intracerebral tumors. [21-24]

References

1. Rozumenko VD. Progressive technologies in surgery of brain tumors. *Onkologiya [Oncology]*. 2012;14(2):97-100. (in Russian)
2. Zozulya YuA, Romodanov SA, Rozumenko VD. *Lazernaya neyrokhirurgiya [Laser neurosurgery]*. Kiev: Zdorovia Publ; 1982. 168 p. (in Russian)
3. Rozumenko VD. Laser surgery of brain tumors. *Fotobiol. ta Fotomed. [Photobiol. and Photomed.]*. 2010;7(3,4):16-22. (in Russian)
4. Ascher PW. *Der CO2-laser in der Neurochirurgie*. Munich: Molden; 1977. 83 p.
5. Eyupoglu IY, Hore N, Savaskan NE, Grummich P, Roessier K, Buchfelder M, et al. Improving the extent of malignant glioma resection by dual intraoperative visualization approach. *PLoS One*. 2012;7(9):e44885.
6. Jain KK. *Handbook of laser neurosurgery*. Springfield: Charles C Thomas Publisher; 1983. 147 p.
7. Krishnamurthy S, Powers SK. Lasers in Neurosurgery. *Lasers Surg Med*. 1994;15(2):126-67.
8. Robertson JH. Carbon dioxide laser in neurosurgery. *Neurosurgery*. 1982;10:780.
9. Rozumenko VD. Neuronavigation technology of virtual 3D planning and intraoperative support of laser thermodestruction of intracerebral tumors of cerebral hemispheres. *Ukr. neirokhirurh. zhurn. [Ukr. Neurosurg. J]*. 2015;3:43-9. (in Russian)
10. Nosov AT, Rozumenko VD, Semenova VM, Medianyuk IO. Morpho-functional changes of the brain under the action of radiation of high-energy carbon dioxide, neodymium-AIH and holmium lasers. *Biul. Ukr. asots. neirokhirurhiv [Bull. of the Ukr. Assoc. of Neurosurgeons]*. 1998;5:136-7. (in Russian)
11. Sigal VL, Bidnenko VN. Mechanism of destruction of tumor tissue with local hyperthermia. *Vestnik novykh meditsinskih tehnologiy [Herald of new medical technologies]*. 2000;4:105-6. (in Russian)
12. Gamache FW, Morgello S. The histopathological effect of the CO2 versus the KTP laser on the brain and spinal cord: a canine model. *Neurosurgery*. 1993;32:100-4.
13. Goebel KR. Fundamentals of laser science. *Acta Neurochirurgica*. 1994;61:20-3.
14. Rossomoff HL, Carroll F. Effect of laser on brain and neoplasm. *Surg Forum*. 1965;16:431-3.

15. Stellar S. A study of the effects of laser light on nervous tissue. Proc 3rd Int Congr Neurol Surg. Copenhagen; 1965; p. 542-51.
16. Rahmathuila G, Recinos PF, Kamian K, Mohammadi AM, Ahluwalia MS, Barnett GH. MRI-guided laser interstitial thermal therapy in neuro-oncology: a review of its current clinical applications. *Oncology*. 2014;87(2):67-82.
17. Eljamel MS, Goodman C, Moseley H. ALA and Photofrin fluorescence-guided resection and repetitive PDT in glioblastoma multiforme: a single centre Phase III randomised controlled trial. *Lasers Med Sci*. 2008;23(4):361-7.
18. Iancu C, editor. *Advances in Endoscopic Surgery*. Croatia: InTech; 2011. Chapter 10, Technical and clinical evolution of modern neuroendoscopy; p. 175-90.
19. Hawasli AH, Kim AH, Dunn GP, Tran DD, Leuthardt EC. Stereotactic laser ablation of high-grade gliomas. *Neurosurg Focus*. 2014 Dec;37(6): E1.
20. Missios S, Bekelis K, Barnett GH. Renaissance of laser interstitial thermal ablation. *Neurosurg Focus*. 2015;38(3):E13.
21. Stranadko EF. Basic mechanisms of photodynamic therapy (literature review). *Fotobiol. ta Fotomed. [Photobiol. and Photomed.]*. 1999;1:36-43. (in Russian)
22. Fedulov AS, Sakovich II, Sliakhtsin SV, Trukhachova TV. Photodynamic therapy of 44 high-grade gliomas with Photolon Results of the open-label randomized clinical trial. *Photodiagn. Photodyn. Ther*. 2008;5:7.
23. Mang TS. Combination studies of hyperthermia induced by the Nd:YAG laser as an adjuvant to photodynamic therapy. *Lasers Surg Med*. 1990;10(2):173-8.
24. Vanaclocha V, Sureda M, Azinovic I, Rebollo J, Cañón R, Sapena NS, et al. Photodynamic therapy in the treatment of brain tumours. A feasibility study. *Photodiagnosis Photodyn Ther*. 2015 Sep;12(3):422-7.

PHOTOTHERAPY IN COMPLEX TREATMENT OF WOUNDS IN PATIENTS WITH ISCHEMIC AND NEUROISCHEMIC FORM OF DIABETIC SYNDROME

Yu.V. Ivanova

*Dr. Sci. (Med.), Principal Researcher
Department of Surgical Infections
SI "Zaycev V.T. Institute of General and Urgent Surgery
of NAMS of Ukraine"
1 Balakirjeva entrance, Kharkiv, 61103, Ukraine
tel.: +38 (057) 349-41-94
e-mail: dr.mushenko@gmail.com
ORCID 0000-0001-8773-6827*

V.A. Prasol

*Dr. Sci. (Med.), Head of the department
Department of Acute Vascular Diseases
SI "Zaycev V.T. Institute of General and Urgent Surgery
of NAMS of Ukraine"
1 Balakirjeva entrance, Kharkiv, 61103, Ukraine
tel.: +38 (057) 349-41-71
e-mail: dr.mushenko@gmail.com
ORCID 0000-0002-0556-6981*

A.M. Korobov

*Cand. Sci. (Phys.-Math.), Head of the laboratory
Science and Research Laboratory of Quantum Biology
and Quantum Medicine
V.N. Karazin Kharkiv National University
6 Svobody Sq., Kharkiv, 61022, Ukraine
tel.: +38 (057) 707-51-91
e-mail: amkorobov@karazin.ua
ORCID 0000-0001-8237-7159*

D.S. Timchenko

*Researcher
Science and Research Laboratory of Quantum Biology
and Quantum Medicine
V.N. Karazin Kharkiv National University
6 Svobody Sq., Kharkiv, 61022, Ukraine
tel.: +38 (050) 011-11-30
e-mail: dimatimchenko2020@gmail.com
ORCID 0000-0002-7456-0583*

D.O. Kirienko

*Postgraduate
Surgery Department No.1
Kharkiv National Medical University
4 Nauky Av., Kharkiv, 61022, Ukraine
tel.: +38 (067) 750-18-73
e-mail: kirden27@gmail.com
ORCID 0000-0001-5290-1159*

E.M. Klimova

*Dr. Sci. (Biol.), Prof., Head of the laboratory
Diagnostic Laboratory with Immunoenzyme and
Immunofluorescence Analysis
SI "Zaycev V.T. Institute of General and Urgent Surgery
of NAMS of Ukraine"
1 Balakirjeva entrance, Kharkiv, 61103, Ukraine
tel.: +38 (050) 303-31-72
e-mail: labionhnamnu@gmail.com
ORCID 0000-0002-4007-6806*

E.V. Mushenko

*Cand. Sci. (Med.), Senior Researcher
SI "Zaycev V.T. Institute of General and Urgent Surgery
of NAMS of Ukraine"
1 Balakirjeva entrance, Kharkiv, 61103, Ukraine
tel.: +38 (057) 349-41-50
e-mail: dr.mushenko@gmail.com
ORCID 0000-0003-0244-3289*

M.V. Pogorielov

*Dr. Sci. (Med.)
Medical Institute
Sumy State University
2 Rymskogo-Korsakova St., Sumy, 40007, Ukraine
tel.: +38 (066) 900-54-48
e-mail: m.pogorielov@gmail.com
ORCID 0000-0001-9372-7791*

M.E. Serbin

*Researcher
Science and Research Laboratory of Quantum Biology
and Quantum Medicine
V.N. Karazin Kharkiv National University
6 Svobody Sq., Kharkiv, 61022, Ukraine
tel.: +38 (095) 202-53-73
e-mail: makserbin@gmail.com
ORCID 0000-0002-0519-3361*

The aim of the study was to improve results of wound healing in patients with ischemic and neuroischemic forms of diabetic foot syndrome by using a combination of phototherapy, platelet-derived growth factor and modern cover materials

The results of surgical treatment of 48 patients with ischemic and neuroischemic diabetic foot syndrome, which were divided into main group (24 patients) and comparison group (24 patients). All these patients who underwent treatment in the Department of acute vascular diseases in the Clinic of the SI "Institute of General and Urgent Surgery named after V.T. Zaitsev of the National Academy of Sciences of Ukraine" suffered from

diabetes mellitus type II and had IV degree of foot ischemia according to Fontaine. The diagnostic was performed for all patients according to a standard algorithm. Analysis of the results of clinical, laboratory, non-invasive and invasive methods of examination in the preoperative period enabled to determine the degree of disorder in blood flow, the nature of collateral circulation and microcirculation. Patients of both groups underwent femoro-tibial and femoro-popliteal bypass, as well as hybrid reconstructions. The parameters of regional hemodynamics in patients of main group and the comparison group before and after revascularization were comparable.

The patients of main group used the treatment technology developed by us. In cases of development of phlegmons of the foot after the opening of the abscess, vacuum therapy was performed for 7–14 days until the wound was completely cleaned. In the preoperative preparation complex, phototherapy was performed, according to local situation, wounds were irradiated with different wavelengths (405, 470 or 525 nm). After the wounds were cleaned, the wound defect was covered with PCL coating (Nanopharma, Czech Republic) with the application of a fibrin clot and platelet-rich plasma without fibrin, after which further local treatment was accompanied by irradiation of wounds with A. Korobov-V. Korobov photon matrices “Barva-Flex” (the wavelength of the maximum of the emission band of 660 nm). In two cases, the closure of bone defects with ILAYAOSTEOGEN® “A.A. PARTNERS” L.L.C. bone implants of medical company “ilaya” was used.

Using these tactics, allow to achieve complete wound healing in 91.7% of patients and partial healing (more than 50%) in 8.3% of patients in main group. The terms of treatment of these patients did not exceed 2 months, high amputations were not required. In patients of comparison group against the background of traditional local treatment, the wounds healed within 2–4 months; in eight cases, repeated hospitalization was required to perform a plastic closure; in two cases amputation was performed below the knee.

Thus, phototherapy and plastic closure of wounds of the lower extremities after revascularization in ischemic diabetic foot syndrome is indicated in cases where the wounds have no tendency to spontaneous healing; introduction of the developed tactics of treatment of “problem” wounds of the lower extremities allowed to achieve complete healing in 91.7% of patients, partial (more than 50%) healing in 8.3% of patients and avoid high amputations; the use of a complex of treatment including phototherapy, wound closure with a synthetic coating with platelet growth factor, and the closure of bone defects with implants is an extremely effective stimulator of development in the wound of granulation tissue suitable for further autodermoplasty.

Key words: ischemic diabetic foot syndrome, dermoplasty, synthetic coatings, phototherapy, platelet growth factor, bone implants.

ФОТОТЕРАПІЯ В КОМПЛЕКСІ ЛІКУВАННЯ ПРИ ПЛАСТИЧНОМУ ЗАКРИТТІ РАН У ХВОРИХ З ІШЕМІЧНОЮ ТА НЕЙРОІШЕМІЧНОЮ ФОРМАМИ СТОПИ ДІАБЕТИКА

Ю.В. Іванова¹, О.М. Клімова¹, В.О. Прасол¹, Є.В. Мушенко¹, А.М. Коробов³,
М.В. Погорєлов⁴, Д.С. Тімченко³, М.Є. Сербін³, Д.О. Кірієнко²

¹ДУ «Інститут загальної та невідкладної хірургії імені В.Т.Зайцева НАМН України», м. Харків, Україна;

²Харківський національний медичний університет, м. Харків, Україна;

³Харківський національний університет імені В.Н. Каразіна, м. Харків, Україна;

⁴Сумський державний університет, м. Суми, Україна

Метою проведеного дослідження було поліпшення результатів лікування ран у хворих з ішемічною та нейроішемічною формами синдрому стопи діабетика шляхом застосування в комплексі лікування фототерапії, тромбоцитарного фактора росту і сучасних покривних матеріалів.

В роботі представлені результати хірургічного лікування 48 пацієнтів з синдромом ішемічної та нейроішемічної діабетичної стопи, які відповідно до завдань дослідження були розділені на основну групу (24 пацієнта) і групу порівняння (24 пацієнта). Всі ці пацієнти, які проходили лікування у відділенні гострих захворювань судин клініки ДУ «Інститут загальної та невідкладної хірургії імені В.Т. Зайцева НАМН України», страждали на цукровий діабет ЦД II типу і мали IV ступінь ішемії стопи по Fontaine. Діагностику проводили всім хворим за стандартним алгоритмом. Аналіз результатів клінічних, лабораторних, неінвазивних і інвазивних методів обстеження в передопераційному періоді дозволяв визначити ступінь порушення магістрального кровотоку, характер колатерального кровообігу і мікроциркуляції. Пацієнтам обох груп виконувалися стегново-гомількове і стегново-підколінне шунтування, а також гібридні реконструкції. Показники регіонарної гемодинаміки у пацієнтів основної групи і групи порівняння до і після ревазуляризації можна було порівняти.

У пацієнтів основної групи застосовувалася розроблена нами технологія лікування. У випадках розвитку флегмон стопи після розтину гнійника проводилася вакуумна терапія ран протягом 7–14 діб до повного очищення рани. У комплексі передопераційної підготовки проводили фототерапію – в залежності від локальної ситуації обробляли рани випромінюванням з різними довжинами хвиль (405, 470 або 525 nm). Після очищення ран від некротів рановий дефект закривали покриттям PCL (Nanopharma, Чехія)

с аппликацією фибринового згустку і плазми, збагаченої тромбоцитарним фактором росту без фібрину, після чого подальше місцеве лікування супроводжувалося опроміненням ран фотонними матрицями Коробова А.-Коробова В. «Барва-Флекс» (довжина хвилі максимуму смуги випромінювання 660 нм). У двох випадках використовувалося закриття дефектів кісток кістковими імплантатами ILAYAOSTEOGEN® «А.А. PARTNERS» L.L.C., medical company «ilaya».

Використання розробленої тактики дозволило досягти повного загоєння ран у 91,7% хворих і часткового загоєння (більше 50%) у 8,3% хворих основної групи. Терміни лікування цих пацієнтів не перевищували 2 місяців, виконання високих ампутацій не було потрібно. У хворих групи порівняння на тлі застосування традиційного місцевого лікування рани гоїлися протягом 2–4 місяців; у восьми спостереженнях була потрібна повторна госпіталізація для виконання пластичного закриття; в двох випадках були виконані ампутації на рівні гомілки.

Таким чином, фототерапія і пластичне закриття ран нижніх кінцівок після операції ревазуляризації при синдромі ішемічної діабетичної стопи показано у випадках, коли рани не мають тенденції до спонтанного загоєння; впровадження розробленої тактики лікування «проблемних» ран нижніх кінцівок дозволило досягти повного загоєння у 91,7% хворих, часткового (більше 50%) загоєння — у 8,3% хворих і уникнути виконання високих ампутацій; застосування комплексу лікування, що включає фототерапію, закриття ран синтетичним покриттям з тромбоцитарним фактором росту, а також закриття кісткових дефектів імплантатами є надзвичайно ефективним стимулятором розвитку в рані грануляційної тканини, придатної для подальшої аутодермопластики.

Ключові слова: синдром ішемічної діабетичної стопи, дермопластика, синтетичні покриття, фототерапія, тромбоцитарний фактор росту, кісткові імплантати.

ФОТОТЕРАПИЯ В КОМПЛЕКСЕ ЛЕЧЕНИЯ ПРИ ПЛАСТИЧЕСКОМ ЗАКРЫТИИ РАН У БОЛЬНЫХ С ИШЕМИЧЕСКОЙ И НЕЙРОИШЕМИЧЕСКОЙ ФОРМАМИ СТОПЫ ДИАБЕТИКА

**Ю.В. Иванова¹, Е.М. Климова¹, В.А. Прасол¹, Е.В. Мушенко¹, А.М. Коробов³,
М.В. Погорелов⁴, Д.С. Тимченко³, М.Е. Сербин³, Д.А. Кириенко²**

¹ГУ «Институт общей и неотложной хирургии имени В.Т.Зайцева НАМН Украины», г. Харьков, Украина;

²Харьковский национальный медицинский университет, г. Харьков, Украина;

³Харьковский национальный университет имени В.Н. Каразина, г. Харьков, Украина;

⁴Сумской государственной университет, г. Сумы, Украина

Целью проведенного исследования было улучшение результатов лечения ран у больных с ишемической и нейроишемической формами синдрома стопы диабетика путем применения в комплексе лечения фототерапии, тромбоцитарного фактора роста и современных покровных материалов.

В работе представлены результаты хирургического лечения 48 пациентов с синдромом ишемической и нейроишемической диабетической стопы, которые в соответствии с задачами исследования были разделены на основную группу (24 пациента) и группу сравнения (24 пациента). Все эти пациенты, проходившие лечение в отделении острых заболеваний сосудов клиники ГУ «Институт общей и неотложной хирургии имени В.Т. Зайцева НАМН Украины», страдали сахарным диабетом СД II типа и имели IV степень ишемии стопы по Fontaine. Диагностику проводили всем больным по стандартному алгоритму. Анализ результатов клинических, лабораторных, неинвазивных и инвазивных методов обследования в предоперационном периоде позволял определить степень нарушения магистрального кровотока, характер коллатерального кровообращения и микроциркуляции. Пациентам обеих групп выполнялись бедренно-берцовое и бедренно-подколенное шунтирование, а также гибридные реконструкции. Показатели регионарной гемодинамики у пациентов основной группы и группы сравнения до и после ревазуляризации были сопоставимы.

У пациентов основной группы применялась разработанная нами технология лечения. В случаях развития флегмон стопы после вскрытия гнойника проводилась вакуумная терапия ран в течение 7–14 суток до полного очищения раны. В комплексе предоперационной подготовки проводили фототерапию — в зависимости от локальной ситуации обрабатывали раны излучением с различными длинами волн (405, 470 или 525 нм). После очищения ран от некрозов раневой дефект закрывали покрытием PCL (Naporhagma, Чехия) с аппликацией фибринового сгустка и плазмы, обогащенной тромбоцитарным фактором роста без фибрина, после чего дальнейшего местного лечения сопровождалось облучением ран фотонными матрицами Коробова А.-Коробова В. «Барва-Флекс» (длина волны максимума полосы излучения 660 нм). В двух случаях использовалось закрытие дефектов костей костными имплантатами ILAYAOSTEOGEN® «А.А. PARTNERS» L.L.C., medical company «ilaya».

Использование разработанной тактики позволило добиться полного заживления ран у 91,7% больных и частичного заживления (более 50%) у 8,3% больных основной группы. Сроки лечения этих пациентов не превышали 2 месяцев, выполнения высоких ампутаций не потребовалось. У больных

группы сравнения на фоне применения традиционного местного лечения раны заживали в течение 2–4 месяцев; в восьми наблюдениях потребовалась повторная госпитализация для выполнения пластического закрытия; в двух случаях были выполнены ампутации на уровне голени.

Таким образом, фототерапия и пластическое закрытие ран нижних конечностей после операции реваскуляризации при синдроме ишемической диабетической стопы показано в случаях, когда раны не имеют тенденции к спонтанному заживлению; внедрение разработанной тактики лечения «проблемных» ран нижних конечностей позволило достичь полного заживления у 91,7% больных, частичного (более 50%) заживления — у 8,3% больных и избежать выполнения высоких ампутаций; применение комплекса лечения, включающего фототерапию, закрытие ран синтетическим покрытием с тромбоцитарным фактором роста, а также закрытие костных дефектов имплантатами является чрезвычайно эффективным стимулятором развития в ране грануляционной ткани, пригодной для дальнейшей аутодермопластики.

Ключевые слова: синдром ишемической диабетической стопы, дермопластика, синтетические покрытия, фототерапия, тромбоцитарный фактор роста, костные имплантаты.

Introduction

Treatment of wounds in patients with ischemic diabetic foot syndrome presents certain difficulties in connection with the feature of the course of the wound process. [1] Monckeberg's sclerosis and arterial calcification are intrinsic for patients with diabetes. These pathological changes are most often determined in the arteries of the shins and feet. In contrast to patients with atherosclerosis with proximal lesions of the arterial bed with a pronounced clinic of shin and foot ischemia and intermittent claudication, patients with diabetes mellitus typically have an occlusive-stenotic lesion of the distal arteries, which often excludes the development of classical intermittent claudication in association with the absence of ischemia of the lower leg muscles, and the combination with the phenomena of diabetic polyneuropathy neutralizes the pain syndrome. All this leads to the fact that manifestation of the disease is most often the development of necrosis of the foot and gangrene of the toes. [1,2]

The presence of polyneuropathy is also of great importance in the pathogenesis of the wound process, in particular, disorder of wound healing processes caused by pathological regeneration. Healing of an ischemic ulcer or a wound of the foot after a debridement is the final goal of surgical treatment, provided the restoration of the blood supply of the foot by a revascularization surgery. [3] However, self-healing of wounds and ulcers is not always possible due to the vastness of the soft tissue defect, sometimes with bone damage, presence of infection, disorder of regeneration against diabetic polyneuropathy, localization of the wound in the "problem area" that is chronically traumatized due to walking, etc. [4]

The aim of the study was to improve the results of wound healing in patients with ischemic and neuroischemic forms of diabetic foot syndrome by using phototherapy (FT), platelet-derived growth factor (TGF), also modern cover materials and bone implants in the complex.

Materials and methods

The results of treatment of 48 patients with ischemic and neuroischemic forms of diabetic foot syndrome were analyzed, which were divided into two groups, according to the purpose of the study. The main

group consisted of 24 patients with ischemic necrosis of toes or feet, who were treated in the Department of Acute Vascular Diseases in the Clinic of the State Institution "Zaycev V.T. Institute of General and Urgent Surgery of NAMS of Ukraine" (SI IGUS) in 2016–2018. The mean age of patients was 67 ± 3.6 years, the duration of diabetes was 11 ± 1.4 years. All patients had type II diabetes and had the IV degree of foot ischemia according to Fontaine.

The comparison group included 24 patients with ischemic necrosis of the toes or foot and wounds after debridement, which were treated in same department of the SI IGUS in 2013–2015. The average age of patients was 64 ± 4.2 years, the duration of the disease of type II diabetes mellitus was 10 ± 1.6 years; all patients had the IV degree of foot ischemia by Fontaine.

The analysis of the results of clinical, laboratory, non-invasive and invasive methods of examination of patients in the preoperative period enabled to determine the extent of the disorder of the blood flow, the nature of the collateral circulation and microcirculation. Diagnostics was done to all the patients according to a standard algorithm:

1) History of disease, clinical and laboratory examination: duration of the disease, intermittent claudication, pain at rest, presence and nature of necrosis, pulse on the main arteries; analysis of laboratory methods of research and anamnesis of comorbidity .

2) Non-invasive examination included determination of the index of regional systolic pressure on the arteries of the foot using a portable ultrasound device "Super Dopplex" (China); ultrasound dopplerography using the Hitachi EUB 7500 device (Japan) with linear sensor L 5–10 MHz; the determination of the oxygen tension (TcPO₂) in the foot tissues percutaneously with the aid of the TCM 400 apparatus "Radiometer Copenhagen" (Denmark).

3) As an invasive study, angiography was performed using "Philips Integris Allura" device (Holland).

In the postoperative period, a control determination of the index of the regional systolic pressure on the arteries of the foot, ultrasound examination of the arterial reconstruction zone and the determination of TcPO₂ in the foot tissues were done.

From 24 patients in the main group, 4 patients underwent femoro-tibial bypass, in 15 cases — fem-

oral-popliteal reconstruction; 5 patients underwent a hybrid reconstructive surgery (femoral-popliteal reconstruction in combination with balloon angioplasty of tibial arteries). 15 patients had wounds after debridement and small amputations on the foot, which could not be closed with auto-dermoplasty; 2 patients had foot phlegmon, and 3 has infected wounds; in 4 patients, wounds were localized on the plantar surface of the foot; in 2 cases there were marginal lesions of the foot bones.

From 24 patients in the comparison group, 18 had a femoral-popliteal reconstruction, 2 had femoral-femoro-tibial bypass, and 4 had a hybrid reconstruction. 13 patients had wounds after necroctomy and small amputations on the foot, 3 patients had foot phlegmon, and 3 had infected wounds; in 5 patients, wounds were localized on the plantar surface of the foot.

Treatment for patients of both groups was prescribed according to the following scheme: compensation of diabetes mellitus (transfer to fractional insulin therapy); metabolic therapy, antibacterial, anticoagulant and vasotrophic therapy; physical methods of treatment; therapy aimed at treating osteoporosis (calcium drugs).

The patients of the comparison group underwent traditional treatment of wounds of the foot after debridement using daily dressings with antiseptics, ointments, sorbents, etc.

In order to improve the results of treatment of wounds and ulcers of the lower extremity, the following treatment methods and their combinations were used in the patients of the treatment group: phototherapy; stage closure of tissue defects with a synthetic coating of polycaprolactone (PCL, Nanopharma, Czech Republic) with application of a fibrin clot and plasma enriched with TGF without fibrin; vacuum therapy with Acti VAC apparatus manufactured by KCI (USA); autodermpoplasty according to Thiersch; free autodermpoplasty with split-thickness skin graft.

For phototherapy in the complex of local treatment of wounds, A. Korobov-V. Korobov flexible photonic (LED) matrices "Barva Flex" were used with different wavelengths of the maximum emission band — 405 nm, 470 nm, 525 nm and 660 nm, which corresponded to violet, blue, green and red spectral ranges, with various therapeutic effects. [5] Indications for the use of FT were long-term ischemia with necrobiosis of wound tissues; the presence of an infected or purulent wound.

The use of vacuum therapy for treatment of wounds of the foot ensured the purification of the wound and the stimulation of the growth of the granulation tissue in the wound for further closure it with a synthetic coating or the performance of autodermpoplasty.

Closure of wounds with a synthetic coating with the application of a fibrin clot and plasma enriched with TGF without fibrin prevented the development of secondary infection, stimulated the growth of connective (granulation) tissue in the wound for subsequent

autodermpoplasty or healing it under the coating by wound contraction. Indications for use of this method for treating wounds in ischemic diabetic foot syndrome were the presence of a defect in the foot tissues, which cannot be closed by autodermpoplasty (the bottom of the wound is represented by bone or adipose tissue, tendons) or the presence of a defect in the foot tissues requiring for closing with own tissues of bone resection, which significantly worsens the foot supportability.

Autodermpoplasty was used for final closure of the wound of the foot after the preliminary stage of treatment. Indications for autodermpoplasty were the presence of a healthy granulation tissue on the bottom of the wound and absence of a tendency to spontaneous healing.

The purpose of closure of the bone defects with the ILAYAOSTEOGEN® ("A.A. PARTNERS" L.L.C., medical company "ilaya") implants was to prevent the development of osteomyelitis and stimulation of osteogenesis.

We developed and applied the following scheme of treatment of the ischemic and neuroischemic diabetic foot.

At the stage of preparation for the revascularization, in the presence of pronounced edema, 3–5 sessions of blue light FT were performed (wavelength of 440–470 nm, duration of the session of 5–10 minutes). In the absence of perifocal edema, light treatment of wounds was done by conducting 3–5 irradiation sessions with green light (wavelength of 520–550 nm, duration of the session of 3–5 minutes). The radiation power density at FT was in the range of 0.1–1.0 W/cm², and the time of exposure to the wound varied depending on its area. The density of the radiation supplied to the wound was on average 30–40 J/cm².

If necessary, phlegmons were opened, surgical treatment of wounds with excision of necrosis and elimination of purulent fouling and vacuum therapy were performed.

After stabilization of hemodynamic parameters and formation of a clear demarcation zone, debridement or amputation of necrotic toes with resection of heads of metatarsal bone was performed. The open wound surfaces were covered with a synthetic coating of polycaprolactone (while modeling the contour congruently to the edges of the wound and fixing with the Prolene 5 suture material, if necessary) with the application of a fibrin clot and plasma enriched with TGF without fibrin.

The plasma was obtained as follows: 20 ml of blood were taken without a preservative from the cubital vein. The blood was ultracentrifuged to obtain a fraction enriched with TGF. A day later, during the second dressing, the remains of the fibrin clot were removed, and the wound coating was irrigated with plasma enriched with an auto-platelet-derived growth factor. In two cases, marginal bone resections were performed with the replacement of defects with

ILAYAOSTEOGEN® (“A.A. PARTNERS” L.L.C., medical company “ilya”) bone implants of appropriate size.

After that, the daily irradiation of wounds with red light was performed (wavelength of 630–660 nm, duration of FT sessions of 10–15 minutes, the frequency of sessions depended on the area of wounds), until conditions appeared for performing plastic closure of defects or healing by wound contraction.

Subsequently, daily dressings were performed with the treatment of the coating with antiseptics (Dioxidin, Octenisept, etc.). If there were no signs of suppuration under the coating, the dressings were performed for 14–32 days with a gradual cutting of the edges of the synthetic coating as wound contraction and marginal epithelialization occurred. In the absence of a tendency to heal wounds after 1 month, the coating was removed and autodermoplasty according to Thiersch or with a split perforated skin graft was planned. With obvious signs of suppuration under the coating (2 cases), it was removed, the wound was sanitized for 3–5 days, and then the wound closure procedure with a synthetic coating was repeated or a system for vacuum treatment of wounds was installed.

In cases of manifestation of infection in the wounds of the feet after revascularization and phlegmon formation, abscesses were opened with the installation of the vacuum system for 7–14 days before the wound was cleaned, after which the developed treatment complex (5 patients) was applied.

When the wound was localized on the plantar surface of the foot (in 4 cases), which complicated the autodermoplasty, the developed method of closure with a synthetic coating was used (the duration of treatment was 1–2 months).

In all cases, the patients signed an agreement for participation in the study. The entire list of studies and the methods of treatment used was approved by the Ethical Commission of the State Institution “Zaycev V.T. Institute of General and Urgent Surgery of NAMS of Ukraine”.

Results and discussion

The parameters of regional hemodynamics in patients of main group before and after various revascularization operations are given in Table 1.

When examining patients of the comparison group after revascularization operations, comparable indicators of regional hemodynamics were determined.

Among the patients of the treatment group, who had the closure of wounds of the foot with the use of polymer coating, in 13 patients spontaneous epithelialization of wounds under the coating in the period up to 35 days occurred. In 9 patients, after the removal of the coating and the surgical treatment of the wound before contact bleeding, autodermoplasty was performed: grafting with split perforated flap for 6 patients and that according to Thiersch for 3 patients. One patient refused autodermoplasty, the wound was gradually healed by secondary tension for 4 months with epithelialization by 70%. In all patients after grafting with a split perforated skin graft, a full epithelialization of the wound was determined after 1 month. In one case, partial (more than 50%) epithelialization of the wound was achieved after grafting according to Thiersch, which required repeated skin grafting.

In 5 patients of the treatment group, who were treated with the use of a vacuum system for phlegmon or infected wounds, it was possible to achieve cleansing of the wounds after 7–14 days of treatment. Subsequently, the developed treatment tactics was applied. The healing time for the wounds was 4–6 weeks.

Of the 24 patients in the comparison group, who received traditional treatment, the wounds were completely healed by secondary tension for 2–4 months and by wound contraction in 8 cases. Reduction of wound area to 50% was observed in 6 patients. In 10 patients, there was no tendency for wound healing and there was a progression of the necrotic process, which in 8 cases required re-hospitalization and plastic closure of the wound, and in 2 cases it caused amputation below the knee.

Clinical case. Patient K., 68 years old, was admitted to the hospital with CLI critical limb ischemia of the right lower extremity in the background of type II diabetes mellitus. He was treated for 2 months in the central district hospital at his place of residence, where an amputation of the first toe with a metatarsal bone was performed for him. According to ultrasound examination and angiography, an extended occlusion of the popliteal and anterior tibial artery was noted. There is extensive necrosis on the foot (in the region of the

Table 1

Indicators of regional hemodynamics in patients of the treatment group before and after revascularization

Type of surgery	Femoro-tibial bypass — 4 (16.7%) cases		Femoral-popliteal bypass — 15 (62.5%) cases		Hybrid reconstructive surgery — 5 (20.8%) cases	
	Before the surgery	After the surgery	Before the surgery	After the surgery	Before the surgery	After the surgery
Index of regional systolic pressure on the arteries of the foot	0.34 ± 0.04	0.82 ± 0.06	0.27 ± 0.03	0.67 ± 0.08	0.19 ± 0.06	0.91 ± 0.05
TcPO ₂ (mm Hg) at the foot	16.8 ± 4.6	48.6 ± 7.5	9.4 ± 3.5	39.6 ± 6.7	5.3 ± 2.5	32.9 ± 5.7

distant 1st toe and the metatarsal bone, in the bottom of one of the wounds, the bonesaw-line of the metatarsal bone with signs of osteomyelitis is visualized (Fig. 1).

After preoperative preparation, which included, in addition to traditional measures, phototherapy with green light (wavelength of 520–550 nm, duration of the session of 3–5 minutes, the frequency of 5 sessions, see Fig. 2), in a planned manner, the femoro-tibial autovenous bypass was performed.

After the revascularization operation, 3 sessions of FT with green light were performed in the local treatment complex, followed by debridement (Fig. 3).



Fig. 1. Patient K., 68 years old. Type of foot at admission



Fig. 2. Phototherapy at the stage of preoperative preparation



Fig. 3. Type of wound after debridement (3 days after surgery)

Later, during dressings, the wound was treated with solutions of antiseptics and daily irradiated with red light (wavelength of 630–660 nm, duration of sessions of 10 minutes).

On 10 day after the revascularization in the dressing room, an edge resection of the changed part of the metatarsal bone was performed, the defect was closed with the ILAYAOSTEOGEN® (“A.A. PARTNERS” L.L.C., medical company “ilaya”) bone implant (Fig. 4). The implementation of phototherapy continued.

On 12 day of treatment in the dressing room, the wound was closed with a synthetic coating of polycapro-



Fig. 4. The wound after surgical treatment and installation of the ILAYAOSTEOGEN® bone implant (shown by an arrow)



Fig. 5. The wound with a fibrin clot (shown by an arrow)



Fig. 6. The wounds are covered with a synthetic coating of polycaprolactone (the appearance of wounds on the 3rd day after the manipulation)

lactone (with contour modeling congruently to the wound edges), and the application of a fibrin clot with plasma enriched with TGF without fibrin according to the developed technique was performed (Fig. 5, Fig. 6).

The patient was discharged on the day 15 after the operation. Later, local treatment was performed in the regime of a day hospital. The wounds healed on the day 31 after the surgery.

Conclusions

1. Phototherapy and plastic closure of wounds of the lower extremities after a revascularization operation in ischemic diabetic foot syndrome is indicated in cases when the wounds have no tendency to spontaneous healing.

2. Implementation of the developed tactics of treatment of “problem” wounds of the lower extremities allowed to achieve their complete healing in 91.7% of patients, partial healing (more than 50%) in 8.3% of patients, and avoid high amputations.

3. In our opinion, the use of a complex of treatment including phototherapy, wound closure with a synthetic coating with TGF, and the closure of bone defects with implants ILAYAOSTEOGEN® is an extremely effective stimulator of development in the wound of granulation tissue suitable for subsequent autodermoplasty.

4. We consider the researching of cellular regeneration mechanisms and histological study of the stages of development of connective tissue under the influence of phototherapy, allodermoplasty and TGF, as well as the feasibility of using a combination of synthetic coatings and TGF with vacuum therapy to be promising directions for the development of this method of treatment.

References

1. Norgren L, Hiatt WR, Dormandy JA, Nehler MR, Harris KA, Fowkes FG; TASC II Working Group. Inter-society consensus for the management of peripheral arterial disease (TASC II). *J Vasc Surg.* 2007 Jan;45:5.
2. Eskelinen E, Luther M, Eskelinen A, Lepantalo M. Infrapopliteal bypass reduces amputation incidence in elderly patients: a population-based study. *Eur J Vasc Endovasc Surg.* 2003;26:65.
3. Eltzhig HK, Collard CD. Vascular ischaemia and reperfusion injury. *Br Med Bull.* 2004;70:71-86.
4. Gibbons GW. Lower extremity bypass in patients with diabetic foot ulcers. *Surg Clin North Am.* 2003;83:659.
5. Korobov AM, Korobov VA, Lesnaya TA. Fototerapevticheskie apparaty Korobova serii “Barva” [Phototherapy Korobov devices of the “Barva” series]. 2nd ed. Harkov: Kontrast Publ.; 2008. 176 p. (in Russian)

MAIN STAGES OF DEVELOPMENT AND MODERN-STATE-OF-ART OF PHOTODYNAMIC THERAPY IN RUSSIA

E.Ph. Stranadko

*Dr. Sci. (Med.), Prof., Head of the department
Department of Laser Oncology and Photodynamic
Therapy
State Scientific Center for Laser Medicine of the Ministry
of Health of Russia
40 Studencheskaya St., Moscow, 121165, Russia
tel.: +7 (917) 533-26-88
e-mail: seph04@yandex.ru
ORCID 0000-0002-1589-7661*

T.I. Malova

*Director general
LLC "Veta-Grand"
38 Malaya Gruzinskaya St., korp. 1, Moscow, 123557,
Russia
tel.: +7 (917) 533-26-88
e-mail: seph04@yandex.ru
ORCID 0000-0003-0689-3754*

The article discusses main stages of 25-year development of photodynamic therapy (PDT) in Russia. It underlines that the initiator of PDT development in Russia was Academician Prof. Oleg Skobelkin, director of the Clinical and Research Center for Laser Medicine, Healthcare Ministry of Russian Federation. He united efforts of some institutions of chemical and physical profile so as to develop home-made photosensitizers (PS) and to develop laser devices for PDT application. In 1990 a group of scientists headed by prof Mironov from Moscow State University of Fine Chemical Technologies named after Lomonosov developed the first Russian PS out of the group of hematoporphyrine derivatives – Photohem. In the State Research and Clinical Center for Laser Medicine Photohem preclinical trials had been conducted, the material and technical basis for clinical trials had been prepared, a permission from Pharmacological Committee of Russia for clinical trials had been received. After that in February, 1992, PDT was used for treating patients with recurrent and metastatic tumors which were absolutely non-perspective for traditional curative techniques.

In the last six years a number of PS of the second generation (Photosense, Alasense, Photoditazine, Radachlorine, etc.) have been developed in Russia; Russian laser devices for PDT and fluorescent diagnostics have been worked out too. PDT clinical application has acquired a wide-scale character. PDT is used in tumors of external and visceral locations, in early and extended pathology stages (palliative) as a component of combined and complex cancer treatment. Currently, PDT is widely used in a number of non-tumoral pathologies in ophthalmology, gynecology, purulent surgery, dermatology, etc. PDT is used not only in institutes and research centers but also in practical medicine. The PDT course is included into educational programs for physicians' post-diploma education. Russian scientists take an active part in international scientific meetings including those of World Photodynamic Association as well as in international research projects.

Key words: photodynamic therapy, stages of development it in Russia, modern-state-of-art.

ОСНОВНИ ЕТАПИ РОЗВИТКУ ТА СУЧАСНИЙ СТАН ФОТОДИНАМІЧНОЇ ТЕРАПІЇ В РОСІЇ

Є.Ф. Странадко¹, Т.І. Малова²

¹ФДБЗ «Державний науковий центр лазерної медицини
Федерального медико-біологічного агентства Росії», м. Москва, Росія;

²ТОВ «ВЕТА-ГРАНД», м. Москва, Росія

В статті представлені основні етапи 25-річного розвитку фотодинамічної терапії (ФДТ) в Росії. Відзначено, що ініціатором розробки методу ФДТ був директор ГНЦ лазерної медицини, член-кореспондент РАМН, професор О.К. Скобелкін. Він об'єднав зусилля низки інститутів хімічного та фізичного профілю для створення вітчизняних фотосенсибілізаторів (ФС) та розробки лазерних апаратів для ФДТ. У 1990 році в Московському інституті тонкої хімічної технології ім. М.В. Ломоносова під керівництвом професора А.Ф. Міронова був розроблений перший вітчизняний фотосенсибілізатор із групи гематопорфірину – Фотогем. У ГНЦ лазерної медицини були проведені прециклічні випробування Фотогема, підготовлена матеріально-технічна база для проведення клінічної ФДТ, отримано дозволи Фармакологічного комітету на клінічні випробування і з лютого 1992 року ми почали застосовувати ФДТ у пацієнтів з рецидивними та метастатичними пухлинами, абсолютно безперспективними для традиційних методів лікування.

В наступні 6 років створено цілий ряд фотосенсибілізаторів другого покоління (фотосенс, аласценс, фотодитазин, радахлорін та ін.) та розроблена вітчизняна лазерна техніка для ФДТ та флюоресцентної

діагностики. Клінічне застосування ФДТ придбало широкомасштабний характер. В даний час ФДТ застосовується при пухлинах зовнішніх та віцеральних локалізацій ракових, ранніх і поширених стадій процесу (паліативна ендоскопічна ФДТ), як компонент комбінованого та комплексного лікування раку різноманітних локалізацій. ФДТ в Росії знайшла широке застосування в цілій низці непухлинних захворювань: у офтальмології, в гнійній хірургії, в оториноларингології, гінекології, дерматології та ін. ФДТ застосовується не тільки в інститутах і наукових центрах, але і в практичних лікувальних установах. В інститутах викладається предмет ФДТ на курсах підвищення кваліфікації лікарів. Російські вчені беруть активну участь у міжнародному співробітництві та виступають з науковими доповідями на конгресах Всесвітньої фотодинамічної асоціації та конференціях з лазерної медицини як в Росії, так і за кордоном.

Ключові слова: фотодинамічна терапія, етапи розвитку, сучасний стан.

ОСНОВНЫЕ ЭТАПЫ РАЗВИТИЯ И СОВРЕМЕННОЕ СОСТОЯНИЕ ФОТОДИНАМИЧЕСКОЙ ТЕРАПИИ В РОССИИ

Е.Ф. Странадко¹, Т.И. Малова²

¹ФГБУ «Государственный научный центр лазерной медицины
Федерального медико-биологического агентства России», г. Москва, Россия;

²ООО «ВЕТА-ГРАНД», г. Москва, Россия

В статье приведены основные этапы 25-летнего развития фотодинамической терапии (ФДТ) в России. Отмечено, что инициатором разработки метода ФДТ был директор ГНЦ лазерной медицины, член-корреспондент РАМН, профессор О.К. Скобелкин. Он объединил усилия ряда институтов химического и физического профиля для создания отечественных фотосенсибилизаторов (ФС) и разработки лазерных аппаратов для ФДТ. В 1990 году в Московском институте тонкой химической технологии им. М.В. Ломоносова под руководством профессора А.Ф. Миронова разработан первый отечественный фотосенсибилизатор из группы производных гематопрופирина — Фотогем. В ГНЦ лазерной медицины были проведены предклинические испытания Фотогема, подготовлена материально-техническая база для проведения клинической ФДТ, получено разрешение Фармакологического комитета на клинические испытания и с февраля 1992 года мы начали применять ФДТ у больных с рецидивными и метастатическими опухолями, абсолютно бесперспективных для традиционных методов лечения.

В последующие 6 лет создан целый ряд фотосенсибилизаторов второго поколения (фотосенс, аласенс, фотодитазин, радахлорин и другие) и разработана отечественная лазерная аппаратура для ФДТ и флюоресцентной диагностики. Клиническое применение ФДТ приобрело широкомасштабный характер. В настоящее время ФДТ применяется при опухолях наружных и висцеральных локализациях рака, ранних и распространенных стадиях процесса (паллиативная эндоскопическая ФДТ), как компонент комбинированного и комплексного лечения рака различных локализаций. ФДТ в России нашла широкое применение при целом ряде неопухолевых заболеваний: в офтальмологии, в гнойной хирургии, в оториноларингологии, гинекологии, дерматологии и др. ФДТ применяется не только в институтах и научных центрах, но и в практических лечебных учреждениях. В институтах ведется преподавание предмета ФДТ на курсах повышения квалификации врачей. Российские ученые принимают активное участие в международном сотрудничестве и выступают с научными докладами на конгрессах Всемирной фотодинамической ассоциации и конференциях по лазерной медицине как в России, так и за рубежом.

Ключевые слова: фотодинамическая терапия, этапы развития, современное состояние.

Twenty five years of development and practical application of photodynamic therapy (PDT) is marked in Russia. Among the European countries, Russia was one of the pioneers of development of clinical PDT. The initiator of the development of the PDT was the head of the Institute, the corresponding member of the Russian Academy of Medical Sciences (RAMS), Professor O.K. Skobelkin. He organized a group of enterprising researchers to create and develop domestic photosensitizers (PS) and develop laser devices for PDT [1-4]. He combined efforts of some institutions of chemical and physical profile. The work was carried out simultaneously in a number of directions. As a result of the experimental studies conducted in the State Scientific Center of Laser Medicine (SSCLM) of Ministry of Health of the Russian Federation, at a

stage of preclinical study of general-toxic and specific types of action of hematoporphyrine derivative, average lethal doses of hematoporphyrine derivative had been determined, the acute dark and light toxicity had been studied, boundaries of therapeutic dose had been determined, depending on various light modes, regularities of a photosensitizing tanatogenesis had been described in the first, which played an important role in the subsequent in development of morphological criteria for the efficiency of PDT in the clinical trials of various PS.

In numerous experiments features of pharmacokinetics at intravenous and intra-abdominal introduction methods of a PS had been studied, indisputable advantages of derivative hematoporphyrine for diagnostics and treatment of malignant tumors before to

other dyes had been fitted. In experiments on rats the high efficiency of PDT at intravenous administration of a PS was proved [5-9]. Special interest in porphyrines was caused by a unique combination of spectral energy and chemical characteristics, which provide not only intensive absorption of light radiation in the visible range of light, but also its transformation with high intensity in energy of highly reactive intermediates, capable to cause deep damages of various components of biological structures, first of all malignant tumors. However, nowhere in the interested research establishments institutes of the country, the clinical trials of PDT with foreign and domestic PS has not conducted yet. In 80th years of the XX century in the Moscow Institute of Fine Chemical Technology named after M.V.Lomonosov under the leadership of the professor A.F.Mironov the extensive studies on the screening of various dyes for detection of photosensitizing properties and chemical modification of hematoporphyrine were deployed. These efforts quickly proved to be very successful and in 1990 it resulted in receiving the first domestic PS from the group of hematoporphyrine derivatives, which was named Photohem [10-14].

Despite of the appearance of the dosage form of Photohem, it wasn't found in clinical conditions of its photosensitizing properties, effective therapeutic dose, the breadth of therapeutic action, the optimal parameters of laser radiation, the phototoxicity and possible other adverse reactions and complications.

Based on previously conducted in SSCLM pre-clinical studies of specific photosensitizing (light toxicity) and general toxic (dark toxicity) of Photohem action, pre-clinical trials of PDT of transplantable tumor in experimental animals [5-7], documents were prepared, permission to clinical trials of Pharmacological Committee of the USSR were obtained, and in February, 1992 was used for clinical trials of the PDT with Photohem [13,15-23].

In SSCLM the material and technical base for conducting clinical PDT had been prepared by that time: the room was equipped and purchased the dye laser "Innova-200", pumped by argon laser, from American firm "Coherent" (wavelength of the light radiation was 630 nm, output power of radiation in continuous mode 5 W). Concurrently domestic lasers and non-laser light sources for PDT with Photohem were developed in the SSCLM together with technical collaborators according to the Programme of development and implementation of the method of PDT in Russia [1,2,4,24-26].

The drug Photohem is the lyophilized sodium salt of hematoporphyrine derivative, obtained from the defibrinated blood and exhibit powerful properties of sensitization tissues to the light radiation of visible range of the spectrum, low toxicity, moderately expressed immunostimulating action. The clinical trials had shown that Photohem is the effective tumor remedy, possessing big and therapeutic breadth, and that it was similar to known foreign PS from group of hematoporphyrine derivatives.

PDT was used for most accessible tumors of exterior locations: skin cancer, intracutaneous metastases of breast cancer and melanoma, cancers of the tongue and oral mucosa. The first patients were with recurrent and metastatic tumors, absolutely unpromising for the traditional methods of treatment (surgery, radiotherapy, combined and even complex). PDT was performed in a hospital, in a specially equipped darkened wards, after tests on a medicinal allergy to Photohem and sensitivity to laser light.

It should be noted that initial clinical trials carried out quite intensely. During the first year 33 patients with various malignant tumors had been treated by the method of PDT. Despite the severe contingent of the patients subjected to PDT, 30 patients of them (91%) were obtained positive effect, including 16 patients (48,5%) which were complete resorption of tumors. The results of the first year of clinical trials of PDT with Photohem were reported at the 1st European Congress from 1 to 3 September, 1993, in Budapest (Hungary) [13]. Based on the results of the first courses of PDT with full or pronounced (more than 50%) resorption of superficial tumors in the absence of complications, we have started to apply interstitial PDT of breast cancer since April, 1992, and in September 1, 1992 for the first time in Russia used endoscopic PDT with central cancer of the lower lobe of the left lung with atelectasis [15-19].

In October, 1992 Moscow Oncology Research Institute named after P.A.Herzen joined the program of clinical studies of PDT [27,28]. In the next years, the clinical application of PDT in Russia had acquired a wide-scale character. Along with 4 capital institutions (SSCLM of Healthcare Ministry of Russia, Moscow Oncology Research Institute named after P.A.Herzen, Oncological and Research centre of RAMS and faculty surgical clinic of I.M.Sechenov Moscow Medical Academy), PDT began to be used in Medical Radiological Research Center of RAMS (Obninsk), the number of regional centers of laser medicine, at the clinical basis of departments of medical universities and in practical medical institutions [11,27,29-33].

In 1994 the PS of second generation Photosens – sulphurized phthalocyanine aluminum (wavelength of the exciting light 675 nm) in SSC "NIOPIK" had been synthesized and submitted for clinical trials. First we reported clinical application of PDT for cancer treatment with various localizations at the Joint Conference of the European Laser Association and International Society of Biomedical Optics, in Lille (France) from 9 to 10 September, 1994 [21]. Subsequently in SSC "NIOPIK" the foreign analog of 5-aminolevulinic acid (ALA) Alasens had been developed and of new PS had been continued development. In future clinical trials of PDT with Photosense within the cooperated clinical trials had been developed and in other Moscow research institutes and in practical medical institutions [4,11,22,23,31,34,35].

Our experience of the first 5 years of clinical application of PDT was reflected in the articles in the first issue of the journal "Laser medicine" [36]. By that time PDT was conducted with 288 patients with 1210 foci of tumors of various localizations.

In 1996-1998 in the Institute of Biomedical Chemistry RAMS named after V.N.Orehovich professor G.V.Ponomarev and his students created a number of the second generation of PS, which were derivatives of chlorin E6 (Photoditazine, Radachlorin, etc.) with a wavelength of 662 nm excitation light, and already in 1998 in the SSCLM had been started clinical trials of Photoditazin [32,37-40]. It was conducted on 78 tumors of the external and internal locations in 72 patients. Photoditazin has a number of advantages over the first generation PS: a high quantum yield of singlet oxygen, a contrast gradient "tumor/normal tissue" 10/1, rapid clearance (short time of a delay in the normal tissues of the body, less than 2 days) and it completely solves the problem of long-term skin phototoxicity, typical for PS of the first generation. With application of Photoditazin the good results of PDT have been received: 70% of tumors have subjected complete resorption. At the present time Photoditazin is the most popular PS for PDT of cancer and many non-neoplastic diseases [35,38,40-45] in Russia. All of the above mentioned PS of the Russian production was registered in the Healthcare Ministry of Russia and have the permission of Pharmacological Committee to application in clinical practice.

The domestic laser equipments for fluorescent diagnostics and PDT were created [1,4,25,35]. In the leading scientific centers of Russia, specialized in laser medicine, oncology and medical physics, experimental and clinical studies of new PS, the methods of fluorescence diagnostics and clinical protocols for PDT of tumors of the main localizations are developed, also of a number of nonneoplastic diseases [46-54]. The offices or the wards of PDT in many territorial centers of laser medicine, regional and city oncology clinics had been organized. For popularization of knowledge of PDT and association of efforts of separate research institutes and centers of laser medicine, we conducted the all-Russian Symposium of photodynamic therapy on the basis of the SSCLM in 1995. In the subsequent, similar symposiums with international participation had carried out every 2 years (1997, 1999, 2001) with the publication of papers on clinical, experimental and technical research [37,55-57].

The breakout sessions of PDT in the framework of All-Russian Scientific-Practical Conference of Laser Medicine have been conducted since 2003. The works of these conferences are published in the journal "Laser medicine" (in Russian). In SSCLM, Moscow Oncology Research Institute named after P.A.Herzen and some educational institutes began to teach a course of laser and photodynamic therapy. The Russian medical press had been published reports of more than 5000 patients

treated with PDT method, which had about 10000 lesions [12,36,58]. Most of these patients were treated for skin cancer. On the one hand, it is connected with availability of lesions of cancer skin, a high efficiency of PDT with this localization of cancer and good cosmetic results, and on the other hand, the fact that skin cancer in Russia (even without melanoma are more than 65,000 new cases annually) since 2007, it occupies the frequency first among all malignant tumors [59,60]. In addition, the widespread introduction of PDT of skin cancer is caused by simplicity of this method in comparison with traditional methods of treatment like surgery and radiation therapy. PDT opens up opportunities of effective treatment for thousands of Russians in the countryside, outside big cities, in which there are surgical and oncological clinics and radiation therapy is conducted.

Another perspective direction of application of this method in Russia is the palliative endoscopic PDT of occlusive malignant tumors of the trachea, large bronchi, esophagus and forestomach, esophageal-intestinal and esophageal-gastric anastomoses [61-65]. One of the last localizations of cancer, which is successfully used in PDT is a cancer of the large duodenal papilla and extrahepatic bile ducts [45,61,62,66,67].

A new promising direction of research is studying the role of PDT in the composition of multicomponent methods of treatment of malignant tumors, which are intensively conducted in the last decade in oncological and X-ray-radiological institutes of Moscow, St. Petersburg, Novosibirsk, Obninsk and other cities of Russia [26,29,33,68-73].

Increasingly popular in Russia becomes anti-bacterial PDT treatment of long-term non-healing wounds with antibiotic-resistant flora, and trophic ulcers of the vascular etiology, acne vulgaris and other inflammatory diseases of soft tissues [46-50,54]. PDT is used for treating of chronic inflammatory diseases of ENT-organs.

The Russian scientists take an active part in the international forums on laser medicine and PDT: at the Congress of the European Laser Association (from 14 to 16 September, 1995, Barcelona, Spain) Russian scientists had made 15 reports, including 9 clinical of PDT. In Vancouver (Canada) at the 8th World Congress of Photodynamic Association from 5 to 9 June, 2001, the Russian scientists had made 6 reports, at the 9th Congress from 20 to 23 May, 2003 (Miyazaki, Japan) — 14 reports, in Munich (Germany) at the 10th World Congress of Photodynamic Association — 11 reports. At the 15th International Congress of the European Medical Laser Association from 20 to 23 August, 2010 (Helsinki, Finland) Russian scientists had made more than 30 clinical reports of PDT and experimental laser biology and medicine.

Currently the international cooperation in the field of researches on the problem PDT continues to expand [20,28,74].

References

1. Armichev AV, Stranadko EPh, Sokolov VV, et al. Experience of using lasers based on copper vapour, gold and dye solutions for photodynamic therapy. In: Mezhd. konf. Novyye napravleniya lazernoy meditsiny [Intern. Conf. The new directions of laser medicine]. M.; 1996; p. 353. (in Russian)
2. Skobelkin OK, Stranadko EPh, Armichev AV, et al. The possibility of creating complex for diagnostics and photodynamic therapy. In: Mezhdunar. konf. Perspektivnyie napravleniya lazernoy meditsiny [Intern. Conf. Perspective directions of laser medicine]. Moscow–Odessa; 1992; p. 434–5. (in Russian)
3. Skobelkin OK, Litvin GD, Stranadko EPh, et al. A new stage of development of PDT of malignant tumors in Russia: the photosensitizer chlorin E6 and solid-state laser of red wavelength range. In: Mezhdunar. konf. Novyye dostizheniya lazernoy meditsiny [Intern. Conf. New achievements in laser medicine]. M.–SPb.; 1993; p. 216–7. (in Russian)
4. Stranadko EPh. Fotodinamicheskaya terapiya. Prime-nenie nizkointensivnyih lazerov v klinicheskoy praktike [Photodynamic therapy. Application of low-intensity lasers in clinical practice]. Skobelkin OK, editor. Moscow; 1997; p. 173–84. (in Russian)
5. Litvin GD, Petukhov MI, Kolobanova AS, Stranadko EPh, Andreeva KP. Research of dark toxicity of Photohem. In: Mezhdunar. konf. Perspektivnyie napravleniya lazernoy meditsiny [Intern. Conf. Perspective directions of laser medicine]. Moscow–Odessa; 1992; p. 74–6. (in Russian)
6. Petukhov MI, Stranadko EPh, Andreeva KP, Kolobanov AC. Study of the light toxicity of Photohem. In: Mezhdunar. konf. Perspektivnyie napravleniya lazernoy meditsiny [Intern. Conf. Perspective directions of laser medicine]. Moscow–Odessa; 1992; p. 428–31. (in Russian)
7. Petukhov MI, Skobelkin OK, Stranadko EPh, et al. Experimental study of specific properties of Photohem. Lazeryi v meditsinskoy praktike [Lasers in medical practice]. Moscow; 1992; p. 274–6. (in Russian)
8. Klebanov GI, Stranadko EPh, Teselkin YO, et al. Interaction of photosensitizers with membranes of liposomes and of erythrocytes. Photochemotherapy: photodynamic therapy and other modalities II, Stanley B. Brown, Benjamin Ehrenberg, Johan Moan, Editors, Proc. SPIE 2924, 1996; p. 205–11.
9. Skobelkin OK, Barabash RD, Andreeva CP, et al. The comparative light toxicity of porphyrin photosensitizers. In: Int. Conf. on PDT, Sofia, 1989; p. 65.
10. Skobelkin OK, Stranadko EPh, Mironov APh, Kolobanov AC, et al. Progress of clinical application of photodynamic therapy of malignant tumors. In: Mezhdunar. konf. Perspektivnyie napravleniya lazernoy meditsiny [Intern. Conf. Perspective directions of laser medicine]. Moscow–Odessa; 1992; p. 3–7. (in Russian)
11. Sokolov VV, Stranadko EPh, Zharkova NN, et al. Photodynamic therapy of malignant tumors of the main localizations with drugs Photohem and Photosens (the results of 3-year observations). Voprosyi onkologii [Questions of Oncology]. 1995;41(2):134–8. (in Russian)
12. Stranadko EPh, Skobelkin OK, Vorozhtsov GN, Mironov APh, et al. Five years experience of clinical application of photodynamic therapy. Ros. onkol. zhurnal [Russian biotherapeutic magazine]. 1998;4:13–8. (in Russian)
13. Stranadko EPh, Skobelkin OK, Mironov AF. Photodynamic therapy of cancer by photogem. Photodynamic therapy of cancer, Giulio Jori, Johan Moan, Willem Star, Editors, Proc. SPIE 2078; 1994; p. 499–501.
14. Stranadko EPh, Skobelkin OK, Vorozhtsov GN, et al. Four-year clinical experience in photodynamic therapy. Photochemotherapy: Photodynamic Therapy and Other Modalities II, Stanley B. Brown, Benjamin Ehrenberg, Johan Moan, editors, Proc. SPIE. 1996; Vol. 2924; p. 298–304.
15. Stranadko EPh. Lazernaya i magnitnaya terapiya v eksperimentalnyih i klinicheskikh issledovaniyah [Laser and magnetic therapy in experimental and clinical studies]. Obninsk, 1993. Chast I, The first experience of photodynamic therapy of cancer in Russia; p. 69–72. (in Russian)
16. Stranadko EPh, Skobelkin OK, Litvin GD, et al. Analysis of the immediate results of photodynamic therapy of malignant tumors. In: Mezhdunar. konf. Novyye dostizheniya lazernoy meditsiny [Intern. Conf. New achievements in laser medicine]. M.–SPb.; 1993; p. 218–20. (in Russian)
17. Stranadko EPh, Astrakhankina TA. Photodynamic therapy of breast cancer. In: Mezhdunar. konf. Novyye dostizheniya lazernoy meditsiny [Intern. Conf. New achievements in laser medicine]. M.–SPb.; 1993; p. 221–3. (in Russian)
18. Stranadko EPh. Experimental and clinical method of laser photodynamic therapy of malignant tumors with using of first and second generation domestic photosensitizers. Lazer-market [Laser market]. 1994;11–12:20–6. (in Russian)
19. Stranadko EPh, Astrakhankina TA. Photodynamic therapy of malignant tumors of the skin. Fizicheskaya meditsina [Physical medicine]. 1994;4(1–2):80–1. (in Russian)
20. Sobolev AS, Stranadko EPh. Photodynamic therapy in Russia: clinical and fundamental aspects. Int. Photodynamics. 1997;1(6):2–3.
21. Stranadko EPh, Skobelkin OK, Litwin GD, Astrakhankina TA. Clinical photodynamic therapy of malignant neoplasms. Photodynamic therapy of cancer II, Daniel Brault, Giulio Jori, Johan Moan, Benjamin Ehrenberg, Editors, Proc. SPIE 2325, 1995; p. 240–46.
22. Stranadko EPh, Skobelkin OK. Our experience of PDT of cancer with two russian produced photosensitizers. Optical Methods for Tumor Treatment and Detection: Mechanisms and Techniques in Photodynamic Therapy IV, Thomas J. Dougherty, Editor, Proc. SPIE, 1995; Vol. 2392, p. 93–105.
23. Stranadko EPh., Skobelkin OK, Litwin GD, Astrakhankina TA. Photodynamic therapy of human malignant tumors: a comparative study between photogem and tetrasulfonated aluminium phthalocyanine. Photochemotherapy: photodynamic therapy and other modalities, Benjamin Ehrenberg, Giulio Jori, Johan Moan, Editors, Proc. SPIE 2625, 1995; p. 440–8.
24. Stranadko EPh, Sloeva AI, Ryabov MV. Photodynamic therapy of malignant tumors in otorhinolaryngology. Yubileyniy sbornik Saratovskogo gos. med. universiteta “Problemyi fizicheskoy biomeditsiny”, posvyaschennyiy 100-letiyu kafedryi patologicheskoy fiziologii im. A.A. Bogomoltsa [The anniversary collection of the Saratov State Medical University “Problems of physical Biomedicine”, dedicated to the 100th anniversary of the Department of pathological physiology named after A.A. Bogomoltsa]. Saratov; 2011; p. 116–31. (in Russian)

25. Stranadko EPh, Armichev AV, Geynits AV. Sources of light for photodynamic therapy. *Lazernaya meditsina [Laser medicine]*. 2011;15(3):63–9. (in Russian)
26. Stranadko EPh, Titova VA, Petrovskiy VYu. Photodynamic therapy: a multimodal programme for the treatment of various localizations cancer. *Lazernaya meditsina [Laser medicine]*. 2012;16(3):4–7. (in Russian)
27. Chissov VI, Skobelkin OK, Mironov APh, Stranadko EPh, et al. Photodynamic therapy and fluorescent diagnostics of malignant tumors with Photohem. *Hirurgiya [Surgery]*. 1994;12:3–6. (in Russian)
28. Betz CS, Raushning W, Stranadko EPh, et al. Optimization of treatment parameters for Foscan-PDT of basal cell carcinomas. *Lasers Surg Med*. 2008;40:300–11.
29. Arsenyev AI, Gelfond ML, Klimenko VN. Intraoperative FDT in the combined treatment of primary and secondary damages of a pleura. *Ros. bioter. zhurnal [Russian biotherapeutic magazine]*. 2008;7(4):12–5. (in Russian)
30. Vasiliev NE, Ogirenko PA. Antimicrobial photodynamic therapy. *Lazernaya meditsina [Laser medicine]*. 2002;6(3):32–8. (in Russian)
31. Volgin VN, Stranadko EPh, Sokolova TV, Lamotkin IA, Ryabov MV. Optimization of the modes of photodynamic therapy of basal cell carcinoma of skin with Photosens. *Lazernaya meditsina [Laser medicine]*. 2007;11(1):50–4. (in Russian)
32. Volgin VN, Stranadko EPh, Sadovskaya MV, Ryabov M.V. Experience of application of photodynamic therapy of basal cell skin carcinoma of different locations with the photosensitizer FOTODITAZIN. *Ros. bioter. zhurnal [Russian biother. magazine]*. 2009;2:31–2. (in Russian)
33. Gelfond M, Arseniev A, Gafton G, et al. Radical and palliative PDT programs in combined treatment of malignant neoplasms. *Proceedings of the III International Symposium "Topical problems of biophotonics". St.-Petersburg–Nizhny Novgorod, Russia*. 2011; p. 323.
34. Lukyanets EA. New photosensitizers for photodynamic therapy. *Ros. himich. zhurnal [Russian biotherapeutic magazine]*. 1998;HLII(5):9–16. (in Russian)
35. Stranadko EPh, Ivanov AV. Modern state of a problem photodynamic therapy of cancer and non-neoplastic diseases. *Biofizika [Biophysics]*. 2004;49(2):380–3. (in Russian)
36. Stranadko EPh, Skobelkin OK, Markichev NA, Ryabov MV. Photodynamic therapy of cancer (five years boundary). *Lazernaya meditsina [Laser medicine]*. 1997;1(1):13–7. (in Russian)
37. Ponomarev GV, Reshetnikov AV, Ivanov AV, Stranadko EPh. Assessment of the biological activity of a new photosensitizer for clinical use of complex chlorin E6 (Fotoditazin). In: *III Vserossiyskiy simpozium. Fotodinamicheskaya terapiya [The III All-Russian Symposium. Photodynamic therapy]*. Moscow; 1999; p. 133–141. (in Russian)
38. Stranadko EPh, Volgin VN, Lamotkin IA, et al. Photodynamic therapy of basal cell skin carcinoma with the photosensitizer Fotoditazin. *Ros. bioter. zhurnal [Russian biotherapeutic magazine]*. 2008;7(4):7–11. (in Russian)
39. Stranadko EPh, Ponomarev GV, Meshkov VM, et al. The first experience of photodithazine clinical application for photodynamic therapy of malignant tumors. *Optical methods for tumor treatment and detection: mechanisms and techniques in photodynamic therapy IX*, Thomas J. Dougherty, Editor, Proc. SPIE 3909, 2000; p. 138–44.
40. Stranadko EPh, Purtskhvanidze VA, Radaev AA. Photodynamic therapy for skin cancer with chlorine derivatives under the outpatient conditions. *Photodiag. Photodyn. Ther.* 2008;5(1):24.
41. Volgin VN, Stranadko EPh. Study of the pharmacokinetics of Fotoditazin basal cell skin carcinoma. *Lazernaya meditsina [Laser medicine]*. 2011;15(1):33–7. (in Russian)
42. Geynits AV, Stranadko EPh. Possibilities of photodynamic therapy with Fotoditazin in Oncology. *Ros. bioter. zhurnal [Russian biother. magazine]*. 2009;2:31–2. (in Russian)
43. Stranadko EPh, Titova VA, Riabov MV, Petrovskiy VYu. Photodynamic therapy of squamous-cellular cancer of head and neck. *Photodiag. Photodyn. Ther.* 2008;5(1):18.
44. Stranadko EPh, Titova VA, Riabov MV, Petrovskiy VYu. Photodynamic therapy as an optimal technique for treating lower lip cancer. *Photodiag Photodyn Ther.* 2010;7(1):18.
45. Stranadko EPh. Photodynamic therapy of the most aggressive forms of malignant neoplasms. *Proceedings of the III International Symposium. Topical problems of biophotonics. St.Petersburg–Nizhny Novgorod, Russia*; 2011; p. 336–338.
46. Stranadko EPh, Tolstykh PI, Teplyashin AS, Koraboev UM. Perspectives of application of photodynamic therapy for treatment of purulent wounds. *Problemy neotlozhnoy hirurgii [Problem of emergency surgery]*. 1998;4:108–9. (in Russian)
47. Stranadko EPh, Koraboev UM, Tolstykh MP. Photodynamic therapy of purulent diseases of soft tissues. *Hirurgiya [Surgery]*. 2000;9:67–70. (in Russian)
48. Stranadko EPh, Tolstykh PI, Urinova Ya, et al. Photodynamic therapy of purulent-inflammatory diseases of soft tissues at patients of elderly and senile age. *Klinich. gerontol. [Clin. gerontol.]*. 2000;6(5–6):43–5. (in Russian)
49. Stranadko EPh, Ivannikov SV, Zharova TA, Shesternya NA. Arthroscopic photodynamic therapy of pigment-villena gonarthroniengitis. *Lazernaya meditsina [Laser medicine]*. 2013;17(3):57–60. (in Russian)
50. Shin PhE, Tolstykh PI, Stranadko EPh, et al. Photodynamic therapy of experimental burn wounds. *Lazernaya meditsina [Laser medicine]*. 2009;13(3):55–60. (in Russian)
51. Fyodorov SN, Kopaeva VG, Andreev YV, Stranadko EPh, et al. First experience of application of photodynamic therapy in keratoplasty. *Laser in Ophthalmology IV*. R. Dirngruber, A.F. Fercher, Ph. Sourdille, Editors, Proc. SPIE 2930, 1996; p. 63–5.
52. Fyodorov SN, Kopaeva VG, Andreev YuV, Stranadko EPh, et al. Photochemical destruction of the newly formed vessels at neovascularization of corneal transplant. *Ophthalmoscope*. 1996(7):46–7.
53. Kopaeva VG, Andreev YV, Stranadko EPh, Ponomarev GV. Photodestruction of neovascular vessels in neovascularization of corneal transplant. In: *The XI-th Congress of International Society for Laser Surgery and Medicine*. Buenos Aires; 1995; p. 129–30.
54. Stranadko EPh, Tolstykh PI, Kuleshov IYu. Antibacterial photodynamic therapy for treating non-healing purulent wounds and trophic ulcers. *Photodiag. Photodyn. Ther.* 2010;7(1): 37.
55. Stranadko EPh. Photodynamic therapy of malignant tumors and non-neoplastic diseases. In: *2-y Vserossiyskiy simpozium. Fotodinamicheskaya terapiya zlokachestven-*

- nyih novoobrazovaniy [The 2nd All-Russian Symposium. Photodynamic therapy of malignant tumors]. M.; 1997; p. 20–3. (in Russian)
56. Stranadko EPh, Garbuzov MI, Markichev NA, Ryabov MV. Photodynamic therapy of recurrent and residual tumors of oropharyngeal area in an outpatient setting. In: 2-y Vserossiyskiy simpozium. Fotodinamichekaya terapiya zlokachestvennyih novoobrazovaniy [The 2nd All-Russian Symposium. Photodynamic therapy of malignant tumors]. M.; 1997; p. 40–6. (in Russian)
57. Stranadko EPh, Ryabov MV, Markichev NA, Volkova NN. The results of the first stages of clinical use of photodynamic therapy for the treatment of malignant neoplasms. In: III Vserossiyskiy simpozium. Fotodinamichekaya terapiya [The III All-Russian Symposium. Photodynamic therapy]. M.; 1999; p. 72–82. (in Russian)
58. Stranadko EPh, Ryabov MV, Furltova NM, et al. The study of antibacterial activity of photodynamic therapy with a new photosensitizer of chlorin range in the experiment *in vitro*. Lazernaya meditsina [Laser medicine]. 2002;6(1):44–7. (in Russian)
59. Chissova VI, Starinskogo VV, Petrovov GV, editors. Zlokachestvennyie novoobrazovaniya v Rossii v 2007 godu (zabolevaemost i smertnost) [Malignant tumors in Russia in 2007 (morbidity and mortality)]. Moscow; 2009. 242 p. (in Russian)
60. Chissova VI, Starinskogo VV, Petrovov GV, editors. Zlokachestvennyie novoobrazovaniya v Rossii v 2011 godu (zabolevaemost i smertnost) [Malignant tumors in Russia in 2011 (morbidity and mortality)]. Moscow; 2013. 289 p. (in Russian)
61. Stranadko EPh, Vasilenko YuV, Lobakov AI, et al. Possibilities of palliative photodynamic therapy in endoscopic practice. Annalyi hirurgii [Annals of surgery]. 2003;2:20–4. (in Russian)
62. Stranadko EPh, Lobakov AI, Vasilenko YuV, Ryabov MV, Mokin AV. Palliative endoscopic photodynamic therapy. Fotobiol. ta Fotomed [Photobiol. and Photomed.]. 2007;1–2:38–42. (in Russian)
63. Stranadko EPh, Lobakov AI, Morohotov VA, Ibragimov TM. Photodynamic therapy of the large duodenal papilla cancer, gall bladder and common bile duct. Ros. bioter. zhurnal [Rus. biother. magazine]. 2009(2):42–3. (in Russian)
64. Stranadko EPh, Mazurin VS, Shabarov VL, Mayorov GA. Treatment of patients with cancer of a gullet by the method of endoscopic photodynamic therapy. Lazer. med. [Laser med.]. 2011;15(2):72–3. (in Russian)
65. Stranadko EPh, Mazurin VS, Shabarov VL. Photodynamic therapy in esophageal cancer. Photodiag. Photodyn. Ther. 2010;7(1):7.
66. Stranadko EPh, Meshkov VM, Vasilenko YuV, et al. Photodynamic therapy of the vater papilla cancer. Lazer. med. [Laser med.]. 2002;6(1):9–13. (in Russian)
67. Stranadko EPh, Lobakov AI, Riabov MV, Ibragimov TM. Photodynamic therapy for papilla of Vater cancer and common bile duct cancer. Photodiag. Photodyn. Ther. 2008;5(1):88.
68. Petrovskiy VYu, Titov VA, Stranadko EPh, Ryabov MV. Photodynamic therapy in multicomponent programmes of treatment of oropharyngeal cancer. Sibirskiy onkol. zhurnal [Siberian oncol. mag.]. 2006;1:84–5. (in Russian)
69. Stranadko EPh, Ryabov MV, Titova VA, Petrovskiy VYu. Photodynamic therapy as the main component of the combined and complex treatment of squamous cell cancer of the head and neck. In: XI mezhdunar. konf. Novyie meditsinskie tehnologii i kvantovaya meditsina [The XI Intern. Conf. New medical technologies and quantum medicine]. Moscow; 2005; p. 105. (in Russian)
70. Stranadko EPh, Titov VA, Ryabov MV, Petrovskiy VYu. Photodynamic therapy of cancer of the lower lip: an experience of use in combination with the traditional method of prevention of metastasis. Lazer. med. [Laser med.]. 2006;10(3):41–7. (in Russian)
71. Stranadko EPh, Titov VA, Ryabov MV, Petrovskiy VYu. Photodynamic therapy in programs multicomponent organ-preserving treatment of squamous cell cancer of the head and neck. In: XXX mezhdunar. nauch.-prakt. konfer. Primenenie lazerov v meditsine i biologii [The XXX Internat. Scient.-Pract. Conf. Application of lasers in medicine and biology]. Yalta; 2008; p. 58–60. (in Russian)
72. Stranadko EPh, Titov VA, Ryabov MV, Petrovskiy VYu. The Role of photodynamic therapy in combined treatment of squamous cell cancer of the head and neck. In: III Evraziyskiy kongress po med. fizike i inzhenerii. Meditsinskaya fizika — 2010 [The III Eurasian Congress on medical physics and engineering. Medical physics — 2010]. Moscow; 2010; 4; p. 269–71. (in Russian)
73. Titova VA, Kharchenko NV, Stranadko EPh, et al. Photodynamic therapy in multimodality treatment of locally advanced and recurrent oral cancer. Photodiag. Photodyn. Ther. 2008;5(1):20.
74. Betz ChS, Raushning W, Stranadko EPh, Ryabov MV, Volgin VN, Albrecht V, Nifantiev NE, et al. Long-Term Outcomes Following Foscan-PDT of basal cell carcinomas. Lasers in surgery and medicine. 2012;44:533–40.

MATERIALS TO THE HISTORY OF KHARKOV CLINIC ESTABLISHED BY DOCTOR G.A. DAVIDOVICH (1895–1920)

K.V. Rusanov

Independent researcher

8 Kosmonavtov St., Ap. 12, Kharkiv, 61103, Ukraine

tel.: +38 (068) 607-64-93

e-mail: kokamoka51@gmail.com

ORCID 0000-0001-6580-2387

E.G. Rusanova

Engineer

Science and Research Laboratory of Quantum Biology
and Quantum Medicine

V.N. Karazin Kharkiv National University

4 Svobody Sq., Kharkiv, 61022, Ukraine

tel.: +38 (093) 849-41-35

e-mail: kokamoka51@gmail.com

ORCID 0000-0001-9820-122X

In memory of Professor Leonid Dmitrievich Tondiy (1933-2018)

Rationale and purpose of the study. At the end of XIX century, in Kharkov, a large private clinic was opened, with modern equipment for physiotherapy. Its work, the names of employees and the role in the development of urban medicine are poorly and unclearly highlighted in the literature. The purpose of the work is to establish according to the source materials the main stages of the history of the hospital and the names of the doctors who played key roles in it.

Sources. The study used annual guides published in Kharkov (city and special medical) and in St. Petersburg (“Russian Medical List”), “Lists of students of the Imperial Kharkov University”; “Kharkov Medical Journal”, the newspapers “Kharkov Provincial Gazette” and “Southern Region”.

Results. It is established that the surgical clinic with an in-patient facility was opened in Kharkov in 1893; the head of the department was the doctor G.A. Davidovich, and the resident physician was P.A. Litsyn, both graduates of Kharkov University. In 1895, G.A. Davidovich became the owner of the clinic (including its building), and P.A. Litsyn became the head; the list of services was added with the treatment of internal and nervous diseases. During the years 1896–1898, a new three-story building was built for the hospital with a special project, and emphasis in its equipment was placed on water treatment and phototherapy. Here, one of the first in Russia electric light baths invented in the early 1890s by an American physician D.H. Kellogg, were installed.

However, in the same year of 1898, G.A. Davidovich died, and the clinic was inherited by his widow Sophia; P. Litsyn remained the head of the department. In 1899, doctor B.I. Spivakov, who graduated from the Kharkov University, was admitted to work in the hospital. Over the next 20 years, yesterday’s student made a great contribution to the further development of the hospital as a physiotherapy hospital.

After the nationalization of the clinic by the Bolsheviks, it became a city hospital, where P.A. Litsyn and B.I. Spivakov continued to work. The latter became an assistant professor, and in 1930 the head of the department of physiotherapy of the Institute for Advanced Training of Physicians. In the mid-1920’s, on the basis of the former clinic of Davidovich, the Ukrainian Institute of Physiotherapy and Balneology was opened.

Conclusion. The hospital of Davidovich, and especially its employee B.I. Spivakov played a significant role in the development of Kharkov medicine, especially in the improvement of physical methods of treatment.

Key words: history of physiotherapy, Kharkov, hospital, electric light baths, doctors, G.A. Davidovich, P.A. Litsyn, B.I. Spivakov.

МАТЕРІАЛИ ДО ІСТОРІЇ ХАРКІВСЬКОЇ ЛІКАРНІ, ЗАСНОВАНОЇ ЛІКАРЕМ Г.А. ДАВІДОВИЧЕМ (1895-1920 рр.)

К.В. Русанов¹, Є.Г. Русанова²

¹Незалежний дослідник, м. Харків, Україна;

²Харківський національний університет імені В.Н. Каразіна,

Науково-дослідна лабораторія квантової біології та квантової медицини, м. Харків, Україна

Обґрунтування і мета дослідження. У кінці XIX ст. в Харкові відкрилася велика приватна лікарня, оснащена сучасним обладнанням для фізіотерапії. Її робота, імена співробітників і роль у розвитку міської медицини слабо і неясно висвітлені в літературі. Мета роботи — встановити за першоджерелами основні етапи історії лікарні та імена лікарів, які відіграли в ній ключові ролі.

Джерела. У дослідженні використані щорічні довідники, видані в Харкові (загальноміські та спеціальні медичні) і в Петербурзі («Російський медичний список»), «Списки студентів Імператорського

Харківського університету»; «Харківський медичний журнал», газети «Харківські губернські відомості» і «Південний край».

Результати. Встановлено, що хірургічна лікарня зі стаціонаром відкрилася у Харкові в 1893 р.; завідувачем служив лікар Г.А. Давидович, а ординатором — лікар П.А. Ліцин, обидва — випускники Харківського університету. У 1895 р. Г.А. Давидович став власником лікарні (включаючи і її будівлю), а П.А. Ліцин — завідувачем; в перелік послуг було додано лікування внутрішніх і нервових хвороб. За 1896-1898 рр. для лікарні був побудований новий триповерховий будинок за спеціальним проектом, а при її обладнанні зроблений акцент на водолікування та світлолікування. Тут були встановлені одні з перших в Росії електросвітлові ванни, винайдені на початку 1890-х рр. американським лікарем Д.Х. Келлогом.

Однак у тому ж 1898 р. Г.А. Давидович помер, і лікарня перейшла до його вдови Софії; завідувачем залишився П.А. Ліцин. У 1899 р. на роботу в лікарню був прийнятий лікар Б.І. Співаков, який закінчив Харківський університет. За 20 наступних років вчорашній студент вніс великий внесок у подальший розвиток лікарні саме як фізіотерапевтичного стаціонару.

Після націоналізації лікарні більшовиками вона стала міською лікарнею, де продовжували працювати П.А. Ліцин і Б.І. Співаков. Останній став доцентом, а в 1930 р. — завідувачем кафедрою фізіотерапії Інституту удосконалення лікарів. В середині 1920-х рр. на базі колишньої лікарні Давидовича відкрився Український інститут фізіотерапії та курортології.

Висновок. Лікарня Давидовича і особливо її співробітник Б.І. Співаков зіграли значну роль в розвитку харківської медицини, особливо в удосконаленні фізичних методів лікування.

Ключові слова: історія фізіотерапії, Харків, лікарня, електросвітлові ванни, лікарі, Г.А. Давидович, П.А. Ліцин, Б.І. Співаков.

МАТЕРИАЛЫ К ИСТОРИИ ХАРЬКОВСКОЙ ЛЕЧЕБНИЦЫ, УЧРЕЖДЕННОЙ ВРАЧОМ Г.А. ДАВИДОВИЧЕМ (1895–1920 гг.)

К.В. Русанов¹, Е.Г. Русанова²

¹Независимый исследователь, г. Харьков, Украина;

²Харьковский национальный университет имени В.Н. Каразина,

Научно-исследовательская лаборатория квантовой биологии и квантовой медицины, г. Харьков, Украина

Обоснование и цель исследования. В конце XIX ст. в Харькове открылась крупная частная лечебница, оснащенная современным оборудованием для физиотерапии. Ее работа, имена сотрудников и роль в развитии городской медицины слабо и неясно освещены в литературе. Цель работы — установить по первоисточникам основные этапы истории лечебницы и имена врачей, сыгравших в ней ключевые роли.

Источники. В исследовании использованы ежегодные справочники, изданные в Харькове (общегородские и специальные медицинские) и в Петербурге («Российский медицинский список»), «Списки студентов Императорского Харьковского университета»; «Харьковский медицинский журнал», газеты «Харьковские губернские ведомости» и «Южный край».

Результаты. Установлено, что хирургическая лечебница со стационаром открылась в Харькове в 1893 г.; заведующим служил врач Г.А. Давидович, а ординатором — врач П.А. Лицын, оба — выпускники Харьковского университета. В 1895 г. Г.А. Давидович стал владельцем лечебницы (включая и ее здание), а П.А. Лицын — заведующим; в перечень услуг было добавлено лечение внутренних и нервных болезней. За 1896-1898 гг. для лечебницы было построено новое трехэтажное здание по специальному проекту, а при ее оборудовании сделан акцент на водолечении и светолечении. Здесь были установлены одні из первых в России электросветовые ванны, изобретенные в начале 1890-х гг. американским врачом Д.Х. Келлогом.

Однако в том же 1898 г. Г.А. Давидович умер, и лечебница перешла к его вдове Софье; заведующим остался П.А. Лицын. В 1899 г. на работу в лечебницу был принят врач Б.И. Спиваков, окончивший Харьковский университет. За 20 последующих лет вчорашній студент внес большой вклад в дальнейшее развитие лечебницы именно как физиотерапевтического стационара.

После национализации лечебницы большевиками она стала городской больницей, где продолжали работать П.А. Лицын и Б.И. Спиваков. Последний стал доцентом, а в 1930 г. — заведующим кафедрой физиотерапии Института усовершенствования врачей. В середине 1920-х гг. на базе бывшей лечебницы Давидовича открылся Украинский институт физиотерапии и курортологии.

Заключение. Лечебница Давидовича и особенно ее сотрудник Б.И. Спиваков сыграли значительную роль в развитии харьковской медицины, особенно в усовершенствовании физических методов лечения.

Ключевые слова: история физиотерапии, Харьков, лечебница, электросветовые ванны, врачи, Г.А. Давидович, П.А. Лицын, Б.И. Спиваков.

In 1998, twenty years ago, the first issue of the journal "Photobiology and Photomedicine" was published in Kharkov. It contained an article by Professor L.D. Tondiy [1] on how phototherapy was developing in our city, starting from the 1860s when, according to Leonid Dmitrievich, the scientists of Kharkov University, who were at the origins of the organization of the resort "Berezovsky Mineral Waters", offered to use sun treatment in the period of recovery.

Later the leading place in photomedicine was taken by artificial — electrical — light therapy. In his article L.D. Tondiy [1] referred the peak of this tendency in Kharkov to the 1920s–1930s. During this period, the Ukrainian Institute of Physiotherapy and Balneology (until 1934), and then the Ukrainian Institute of Experimental Physiotherapy (until 1937) functioned in our city. Specialists in light therapy were trained by the Department of Physiotherapy of the Ukrainian Institute for Advanced Training of Physicians (currently Kharkov Medical Academy of Postgraduate Education), where professor E.A. Chernikov and Associate Professor B.O. Spivakov worked. In Kharkov, the First (1925) and the Third (1935) All-Union congresses of physiotherapists were held. [1]

Due to the constant interest of Professor L.D. Tondiy in the history of photomedicine, we took up the solution of a number of forgotten or controversial issues of the past, related to phototherapy in Kharkov. We managed to make a more accurate picture of the first period of the formation of the Berezovsky Mineral Waters, to find information about some forgotten light-therapy rooms that operated in Kharkov in the 1900s, and so on. [2–4]

In the times of the Russian Empire, phototherapy in our city was used by doctors who were the owners of private phototherapeutic rooms or complex clinics, which included such offices. Kharkov citizens borrowed methods of treatment with light and equipment for it either abroad, or in representative offices of foreign manufacturers in Russia.

The popularity of phototherapy among doctors and patients was facilitated by the well-known success of the Dane N.R. Finsen, the Nobel Prize winner in Physiology and Medicine in 1903, awarded to him "in recognition of his merits in the treatment of diseases — especially lupus — with the help of concentrated light radiation". Thanks to this award and well-organized PR, the Finsen's method was known as the only theoretically grounded method of phototherapy. Therefore, the

Kharkov doctor N.P. Sudeykin [3] not coincidentally named his light therapy office as Finsen in advertising.

There were dozens of private hospitals and medical offices in Kharkov; in the 1900s–1910s approximately half of them offered certain types of light therapy. At the same time, because of competition, most of the private hospitals and offices in the city had huge financial difficulties; their owners often changed, they closed and reappeared.

On this unsteady, unstable background, "The clinic established by Dr. G.A. Davidovich" on the Blagoveshchensk street (until recently — Karl Marx) remained the symbol of stability in our city for many years. And in it, of course, there was a light therapy room (Fig. 1) equipped with equipment modern at the time.

However, the project of G.A. Davidovich did not immediately acquire a physiotherapeutic profile; at first, it was a purely surgical hospital. Its transformation is described in the book I.Yu. Robak "Організація охорони здоров'я в Харкові за імперської доби (початок XVIII ст. — 1916 р.)". [5] However, the author of this monograph almost did not provide exact dates, confining of terms like "first", "later", "soon", etc. He did not report the address of the Davidovich's clinic, nor the names of the doctors who worked in it or the biography its founder Grigory Abramovich Davidovich.

According to I.Yu. Robak, the Davidovich's clinic held its genealogy from the "Surgical clinic established by Professor V.F. Grube" on the Blagoveshchensk street in 1890. University surgeon V.F. Grube was the founder and director of this medical institution, but the *actual owner* of the latter was named by I.Yu. Robak as G.A. Davidovich. [5] Later (when?) the clinic was named after Dr. Davidovich; the latter soon died, but "managed to open a hydropathical establishment in a neighboring building (which?) and equip it with popular at that time imported hydrotherapeutic devices. The institution was named "Hydropathical establishment and clinic of the widow of Dr. S.V. Davidovich", its owner not only continued her husband's business but also expanded it. In a separate building (the third?) there



Fig. 1. Fragment advertising the hospital Davidoviche from the directory "All of Kharkov" second half of the 1900's.

was a boarding house for mentally disabled patients. Treatment of sexual disorders was started. For the hydropathical establishment, the baths and showers of all existing systems and other new equipment were purchased". [5]

* * *

It is possible to clarify this complicated question only by relying on the facts cited in the original sources. What was the purpose of our research.

In the "List of students of the Imperial Kharkov University for the 1880–1881 academic year", Davidovich Grigory Abramovich, a Jew from the merchant class, was under number 14 in the medical department among the students in the fourth year, who entered the university on August 16, 1876 after the graduation of the Third Kharkov gymnasium. From other sources, it is known that the student Davidovich was born in 1856. But his birthplace is not indicated, so we have no reason to consider Grigory Abramovich (sometimes – Avramovich) as a Kharkovite.

G.A. Davidovich gained a doctor's diploma in 1882. In addition, the annual "Russian Medical Lists" reported that in the late 1880s he practiced freely in the city of Lugansk, Ekaterinoslav province, and in the early 1890s he was a doctor of the Lugansk city training school and obtained a rank of a collegiate assessor. G.A. Davidovich moved to Kharkov no earlier than the end of 1892. Here he was considered a freely practicing physician up to 1897, inclusive, after which he was permanently withdrawn from the lists. Grigory Abramovich was never a doctor of medicine.

Urban annual reference books "Kharkov Calendar" for 1890–1892 did not report the existence of a "Surgical Clinic established by Professor V.F. Grube". The first mention of it was made in the "Kharkov calendar" in 1893:

"Surgical clinic established by prof. V.F. Grube (Blagoveshchenskaya Str., 12). The head of the clinic is Dr. G.A. Davidovich, the resident doctor is Dr. P.A. Litsyn.

There is room for 25 surgical patients. In addition to separate rooms, there are common chambers. The operations are carried out by the founder and director Prof. V.F. Grube. Payment for operations and premises is agreed. At the hospital, there is one free bed, and there are two for emergency cases".

This information is repeated in the "Kharkov calendars" for 1894–1895.

Neither V.F. Grube nor his above-mentioned employees were then owners of houses on the Blagoveshchenskaya Street. According to the "Lists of landlords of Kharkov for 1890", house number 10 belonged to the heirs of Captain A.P. Strakhov, and house number 12 – the noblewoman E.N. Boguslavskaya.

Apparently, the famous Kharkov surgeon V.F. Grube (1827–1898) chose G.A. Davidovich and P.A. Litsyn as employees of the hospital because he knew them and

trusted them. He probably remembered these doctors as his students at the university.

However, we did not find the data on the medical specialization of Grigory Davidovich (and his interest in physiotherapy). But P.A. Litsyn exactly was a surgeon: in advertising of his home appointment, he invited patients with surgical and dental diseases. At the same time he worked in the hospital on the Blagoveshchensky Street for over 30 years and, of course, became part of its history.

From the "List of students of the Imperial Kharkov University for the 1879–1880 academic year" it can be seen that Pavel Litsyn, born in 1854 and being a fifth-year student, was of the Orthodox faith, came from a merchant class, graduated from a gymnasium in Taganrog and, on August 16, 1874, he entered the medical department and studied at his own expense. "Russian medical lists" reported on P.A. Litsyn that, having received a doctor's diploma in 1880, he remained to live in Kharkov, where he worked as a railway doctor.

Pavel Anastasievich was born in a Taganrog merchant family which originated from Greek immigrants: his father was a merchant of the Third Guild, who traded "red goods", and his mother, born Makropulo, was the daughter of a rich Taganrog merchant.

The road to the medical faculty in Kharkov was laid for Pavel by his elder (13 years) brother Nikolai Litsyn (1841–1920), who got a medical diploma in our university in the 1860s. N.A. Litsyn went to work in his native city, where he became famous – though not so much in medical, as other activities. For a long time he was the chairman of the first Mutual Credit Society in Taganrog, the foreman of the Taganrog exchange committee; was the head of city training schools; from 1872 he was elected as a member of the town council (in the meeting room of which his portrait was posted), and from 1897 to 1905 he was the city head of Taganrog.

In addition, Nikolai Litsyn rose to the "general" rank of an actual state councillor, had the Order of St. Anna of the 2nd degree, the Order of St. Vladimir of the 3rd degree, etc.

However, his brother Pavel was much more modest. He did not have real estate in Kharkov and lived in a rented apartment on the Ekaterinoslavskaya street (now the Poltava route), in the house No. 37. P.A. Litsyn did not rise to ranks, and he did not get a doctor's degree. He avoided politics, which later contributed to the longevity of the doctor.

In contrast to him, G.A. Davidovich, who was at first the hired manager of the "Surgical Hospital", launched activities aimed at moving the latter into his own hands. Most likely, he did this with the consent of the already very old V.F. Grube.

As can be seen from the "List of homeowners of Kharkov" in 1895, Grigory Abramovich bought the house No. 10 on the Blagoveshchenskaya street with an estimated value of 3120 rubles. (the owner of the house No. 12, valued at 12060 rubles, remained

E.N. Boguslavskaya). At the same time, G.A. Davidovich registered a new charter of the clinic through the authorizing bodies, where he himself was already the owner (Fig. 2).

On November 29, 1894, the charter was approved by the Minister of the Interior and the Director of the Medical Department. Here are some fragments from this document (there are more than 20 clauses in it):

“1. The hospital was established with the aim of delivering medical aid, accommodation, care and maintenance that meet modern requirements of science for patients, especially for non-residents, for a moderate charge, as well as aseptic and antiseptic requirements for operated patients.

2. The clinic consists of an outpatient facility and rooms both general and separate for the placement of inpatients; there is also an operating room equipped with all kinds of instruments; laboratory for the preparation of sterilized material and disinfectant liquids; the insulation room; a special room for admitting visiting patients, a pharmacy (without the right to free sale) with the medicines required to provide initial assistance; a bathroom, electrical appliances and so on.

3. The hospital belongs to Dr. G.A. Davidovich who is the head of the clinic; in addition, it involves one or two permanent resident physicians who visit patients twice a day at certain times or more, if necessary, at any time; and there is a sufficient staff of experienced servants in the clinic. <...>

5. Persons of both sexes of all ages are admitted as inpatients at all times, and the female patients are placed in rooms separate from men: a) with diseases requiring surgical assistance, including eye, urogenital and gynecological diseases, with a department for obstetric cases; b) with internal diseases. The incoming patients are admitted daily at certain times.

6. The insane patients and those suffering from acute infectious diseases (typhoid, smallpox, diphtheria, etc.) are not admitted to the institution. If any of those admitted to the hospital have this kind of disease, then his relatives and the administration must take measures to remove such a patient from the hospital. If this proves impossible, then such a patient must be transferred to an isolation room at the clinic.

7. Every patient entering the clinic is required to submit a legalized residence permit, which, upon presentation to the police, is kept by the head of the clinic and returned to the patient upon his exit from the clinic. <...>

9. Every patient admitted to the hospital enjoys full ready maintenance and treatment, such as: a room, lighting, table and bed linen, food, servants, baths and bandages and all the medical aids of the clinic, as well as advice and care of the entire medical staff. In addition, the patient uses the library, magazines, newspapers of the clinic, and other entertainment permitted for patients. With the permission of the head, the patients can use the clothes, linen and bed brought

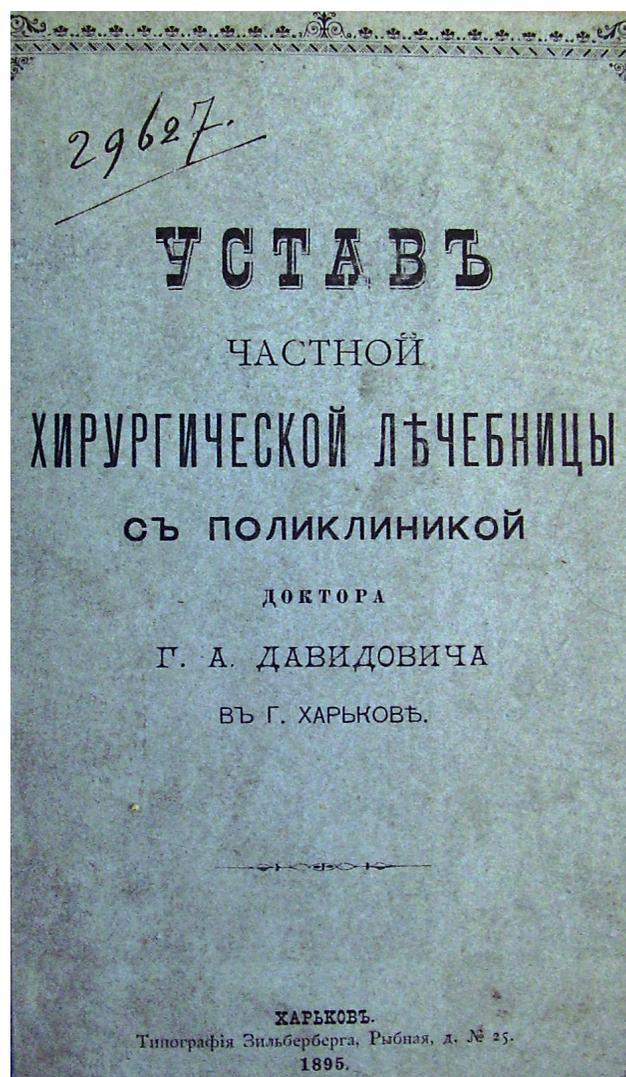

Fig. 2. The cover of the statute of the clinic G.A Davidovich [6]

with them but, in this case, all these things must be preliminarily subjected to thorough disinfection in a device specially designed in the hospital for this purpose. <...>

12. Payment for maintenance, medical care, dressings and dressing material, baths and others at the indication of a specialist who treats this patient, is determined by mutual agreement. Its size (from 2 rubles 50 kopecks a day and 60 rubles per month) depends on the complexity and difficulty of treating a certain case, the patient's requirements, the degree of his material well-being and the duration of his stay in the clinic. Accordingly, as well as the scientific interest, in this case, one and not more than two patients can be also taken free of charge. The fee is paid by patients in advance when they enter the hospital for all the period determined for him or her in the clinic or for 10 days. In the event that the patient leaves the institution before the expiration of the term, the fee is returned back to him with the calculation.

13. In the event of the death of a patient and the absence of relatives, the clinic takes appropriate measures to bury the deceased at its own expense and

promptly notifies the Medical Department and the police about each death case. The document of the deceased, as well as the remaining money and things, is forwarded to the proper institution". [6]

The other paragraphs of the charter of the clinic contained the rules for carrying out the operations; registration of patients and their deposit of clothing, money and things. It was reported on the regular supervision of the hospital by the governor and the provincial medical department, the need to report annually on its activities. It was required from patients to observe the regime established in the clinic "in the forms of successful activities"; meetings with relatives were permitted provided that the visitors gave in the clothes and all the things brought for disinfection.

Information about the opened clinic, published in the "Kharkov calendar" for 1896, added several new details to the charter:

"The hospital of Dr. G.A. Davidovich (Blagoveshchenskaya Str., 12). Senior resident Dr. P.A. Litsyn.

The hospital accepts patients with the following diseases: a) surgical, including for operations of the eye, genitourinary and female organs, and b) internal and nervous. The clinic can accommodate up to 32 patients with separate rooms. Two beds are free; one of them is for eye diseases named after prof. L.L. Girschman."

In addition, in this guide, it was reported that G.A. Davidovich lives on the Blagoveshchenskaya Street, in his own house No. 10.

The above data (repeated in the "Kharkov calendars" in 1897 and 1898) showed that at first in the "clinic of Dr. Davidovich" the physiotherapeutic methods of treatment by no means dominated: the baths and electric appliances were mentioned in the charter tangentially.

* * *

However, during these years Grigory Abramovich rebuilt his own house No. 10 — in fact, he built in its place a new three-story building, specially designed for the hospital of physiotherapy profile. City guide, printed in early 1898, was published before the opening of the latter, and the newspapers were the first which told the Kharkovites about this event.

"**Kharkov Province Gazette**" published such a note on August 6, 1898:

"A large therapeutic institution will be opened soon in Kharkov on Blagoveshchenskaya street — a hydropathic clinic of Dr. Davidovich, built with all sorts of devices for treating with water, electricity, steam, gymnastics, massage, etc.

The entire building with a water-raising tower with a height of 35 arshins was built by the city architect Dashkevich.

The interior is characterized with the elegance of the decoration and comfort. The bathing room is designed in Moorish style with waterproof floors and

walls and with the latest ventilating devices. In this room, besides the pool, there are baths of all kinds and purposes, ranging from simple bathing ones to such novelties in the field of electrotherapy as an *electric light bath for sweating*. There are also various tools for general, local showers etc. For those who do not want to use the baths in the common room, there are several isolated rooms.

In addition to hydrotherapy, the new clinic will widely use electrotherapy, for which there are various special devices.

The heating of the clinic is steam-electric, and the lighting is electric, for which there is own electric generator. For visitors or seriously ill, a boarding house is arranged. The hospital is administered by the doctors Dikansky and Litsyn."

"Southern Region" on October 14, 1898, reported the opening of the hydropathic clinic of Dr. G.A. Davidovich already *post factum*, noting in particular that "for the first time in Russia, carbon dioxide and electric light baths are used" in it.

Electric light (otherwise — photoelectric) baths were invented in the early 1890s by an American physician John Harvey Kellogg. According to the Soviet textbook of physiotherapy, these devices were a multi-faceted box-cupboard (Fig. 3). [7] The patient was sitting inside the bath on a chair; in the upper lid, there was a neck slot for the head to be outside during the procedure. On the inner surface of the bath, there were incandescent lamps (usually coal, of 16 or 25 candles) with reflectors made of metal mirrors or milk glass tiles. The lamps could be switched on in various amounts and combinations to achieve the desired effect.

This was considered to be profuse sweating coming faster and at a lower temperature than in a hot air-dry bath. A strong effect of electric light baths was attributed to the "direct effect on the body of radiant energy in the form of infrared and visible rays of numerous light bulbs". [7]

D.H. Kellogg (see below about him) reported on the favorable results he achieved with this method in case of obesity, diabetes and the Bright disease (nephritis). Electric light baths quickly gained popularity in Europe; they began to treat other metabolic diseases (for example, gout), poisoning, rheumatism, even heart diseases and bronchial asthma.

The manufacturers of medical electrical equipment have developed the designs of electric light baths with more efficient use of radiant energy due to the special form of lamps and reflectors. In Russia, representative offices of Western companies offered electric light baths of "intensive" class at a price of up to 1500 rubles — Radiotherm (Reiniger, Gebbert and Schall) and Polysol (Sanitas).

Even at the turn of the century, local electric light baths were used widely enough — to affect any one part of the body; there is every reason to think that they

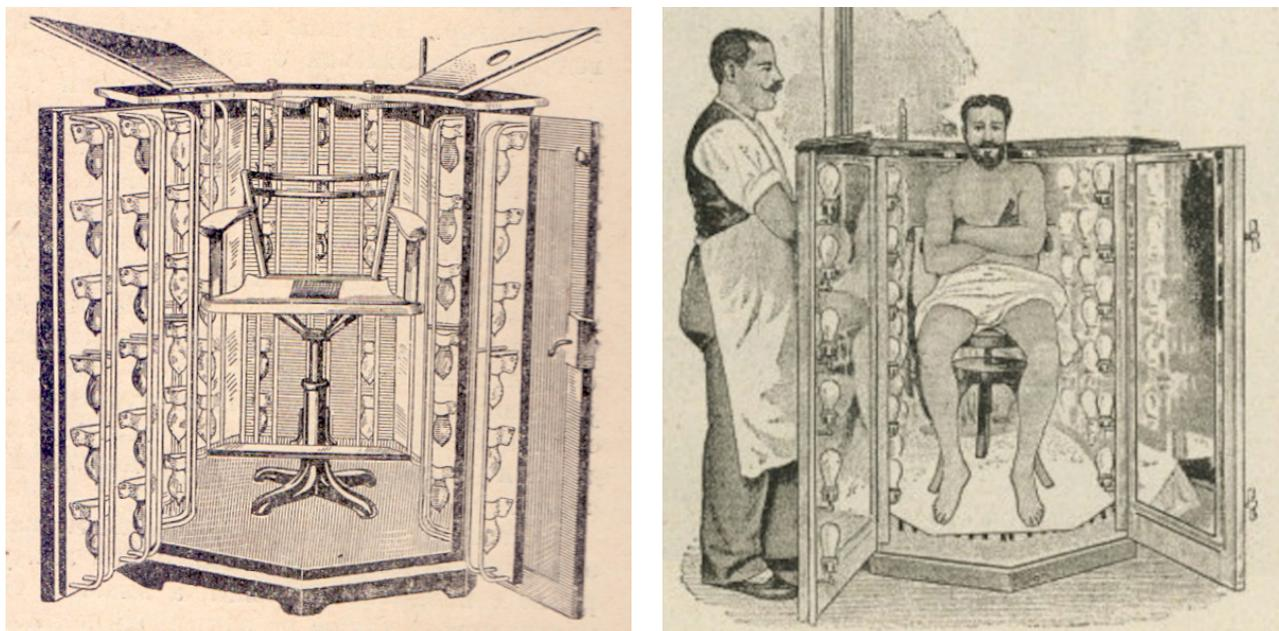

Fig. 3. General electrolight bath: on the left — a picture from the book [7]; right — American advertising early XX century

were available in the hospital of Davidovich. These devices, also equipped with incandescent lamps, had a different size and shape (Fig. 4). It is easy to see that they were prototypes of modern devices for phototherapy of the diabetic foot syndrome, where miniature light-emitting diodes are used as radiation sources.

But back to the newspaper note, to pay attention to two important details. The new building of the clinic was designed by Mikhail (Mitrofan) Irodionovich Dashkevich, the city architect in Kharkov since 1893. By the way, it had an estimated value of 33,300 rubles which was more than 10 times more expensive than the one bought by G.A. Davidovich (data from the “List of homeowners of Kharkov” in 1909, where the owner was the widow of collegiate assessor Sofya Vladimirovna Davidovich).

Grigory Abramovich himself was named in the “Provincial Gazette” only as the founder of the institution, whereas the directors were Litsyn and Dr. Dikansky already known to us. Yakov Lazarevich (Eleazarovich) Dikansky, of the same age as G.A. Davidovich, entered the medical faculty of Kharkov University in 1880, four years later. At the same time Ya.L. Dikansky was a fellow countryman of P.A. Litsyn in Taganrog, he also was from a merchant, but Jewish family. Having received a doctor’s degree in internal medicine in 1886, Yakov Lazarevich settled in Kharkov for the next 30 years. He was engaged almost all the time in private practice at Yaroslavskaya str., 2.

Most likely, Ya.L. Dikansky, personally acquainted

with P.A. Litsyn and G.A. Davidovich, was the head of the clinic because Grigory Abramovich died by the middle of 1898, or could no longer work. And the son-heir of the founder, Alexander Grigorievich Davidovich, was still a boy: he was born in 1888 and got a doctor’s degree in nervous diseases in 1916. [8] So the clinic was re-registered with Sofya Vladimirovna, while continuing to be called “established by Dr. G.A. Davidovich”.

Ya.L. Dikansky, a decorative figure, was soon replaced in the hospital by other doctors. It’s advertising in the guide (Fig. 5) contained their surnames: A.A. Govseev and B.O. Spivakov. [9]

“Alphabetical list of students of the Imperial Kharkov University” for the autumn semester of 1893-1894 reported that the student Alexander Gosveev, of a Jewish faith, was studying at the third year of the medical faculty and granted relief from fees for learning by the University Board.

According to the “Russian Medical Lists”, Alexander Akimovitch Gosveev was born in 1872, gained the title of a physician for internal diseases in 1895, after which he was a supernumerary resident physi-

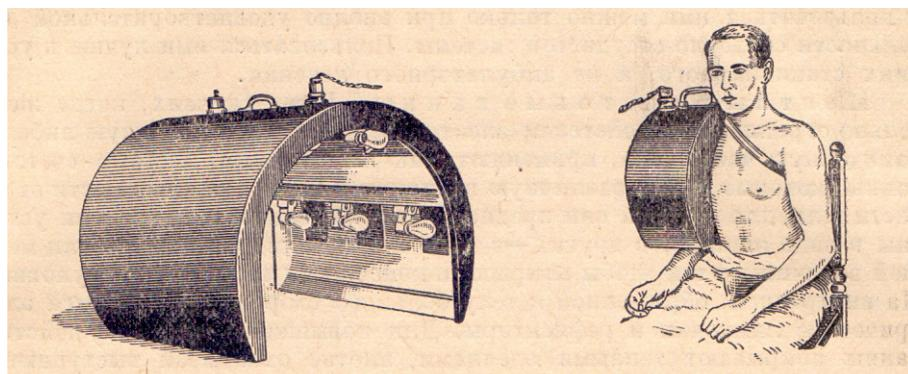

Fig. 4. Apparatus for local electrolight baths [7]: on the left — for the trunk and legs of the patient; right — for the shoulder joint

cian of the clinic (probably university) for several years in Kharkov. He had two older brother-doctors (one of them was a doctor of medicine), who lived in other cities.

Without having any kindred support in Kharkov (and, apparently, craving for physical methods), Gosveev Jr. did not stay long in the Davidovich hospital. Already in 1903 he was a territorial sanitary doctor in Lugansk, later engaged in private medical practice in Yekaterinoslav (with his brother Albert), and in 1915 he was the head of the territorial sanitary bureau in Kiev.

The future associate professor Boris Osipovich Spivakov was a completely different person, who was noted by L.D. Tondiy in the article. [1] Unfortunately, later on, Leonid Dmitrievich added very little to Spivakov's description. In the last work it was noted only that "in 1930 the Department of Physiotherapy (in Kharkov) was headed by B.O. Spivakov, an experienced therapist and balneologist, who was the head of the hydropathic institution in the building No. 10 on Karl Marx street (Blagoveshchenskaya) and worked in the scientific council of the Kharkov Scientific Society". [10]

But today we can already say that the Davidovich's hospital was the first (and desired!) place of service for the young doctor Boris Spivakov after graduating from Kharkov University. Over the years of work in this private medical institution, Spivakov grew into an ideological leader, we believe that it was he (and not the nominal head, the surgeon Litsyn) that determined the direction of the development of the clinic.

From the "List of students of the Imperial Kharkov University," it is clear that the student Spivakov Bention Iosifovich was born on June 13, 1875, in Odessa, a Jewish middle-class family, graduated from the Third Odessa City Gymnasium and on September 6, 1894, entered the Medical Department.

In 1897, he studied in the third year, and in 1899 received a doctor's degree in internal and nervous diseases. In 1901 a talented Odessa resident lived in

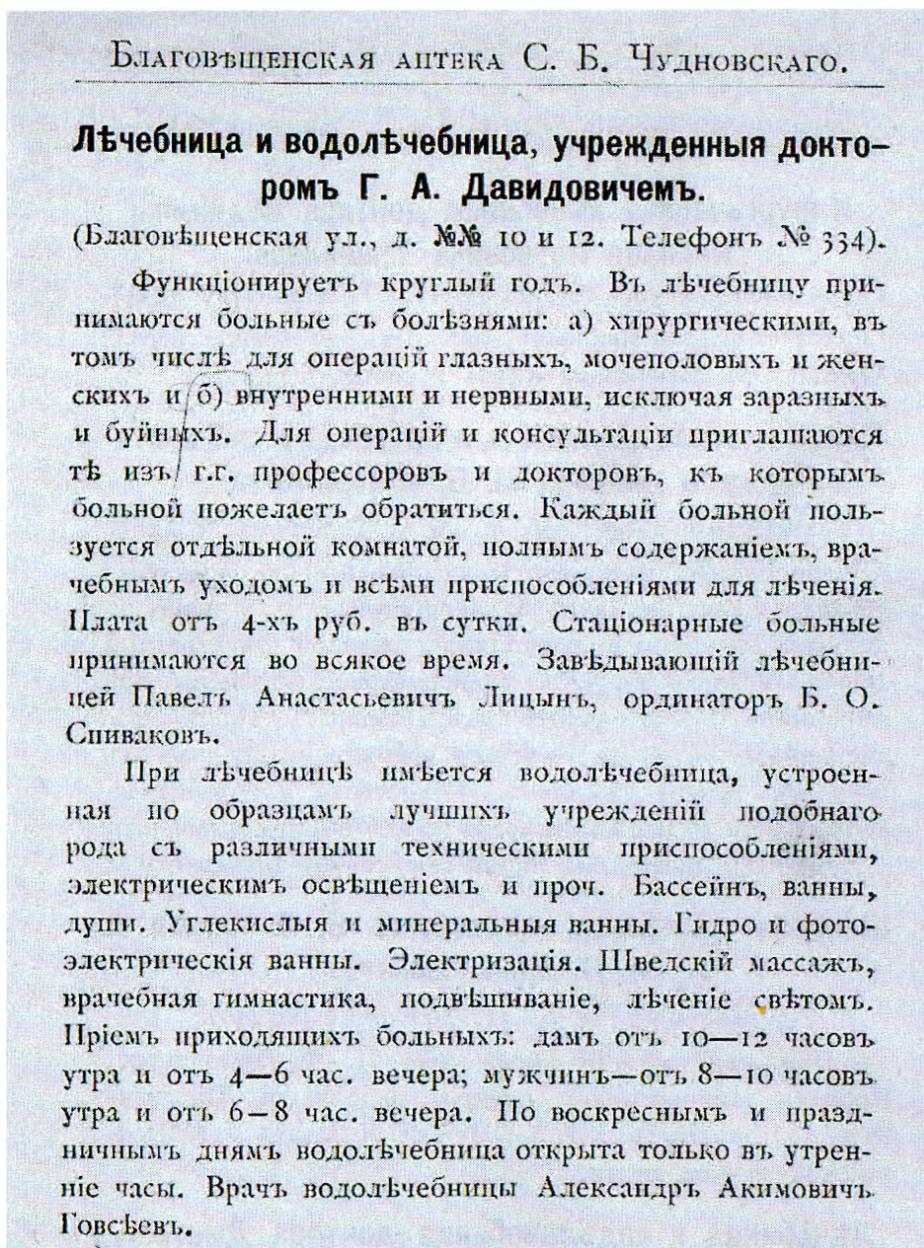

Fig. 5. Fragment of the reference book [9]

Kharkov at the address: Blagoveshchenskaya str., 10, that is, directly at the place of work. [9]

It is known that he often went abroad to the conference on physical methods of treatment and, having returned, he made reports for his colleagues in Kharkov about new products in this area. So, on May 18, 1913, B.I. Spivakov reported on the topic "Radium therapy and electrotherapy at the 4th Congress on Physiotherapy in Berlin" at a meeting of the Kharkov Medical Society.

Actually, the formulary list of Bention Iosifovich Spivakov, the resident of the private clinic of Davidovich in Kharkov, which was compiled in 1911, is kept in the Russian State Historical Archive (Fund 1349, inventory 2, portfolio 404, sheets 71–73). Now it is beyond our reach, but in Soviet times it was not so difficult to look at this document.

* * *

On the bookshelf in the office of Boris Spivakov on the Blagoveshchenskaya street, 10, there certainly was the fundamental work of the inventor of electric light baths (Fig. 6).

Dr. D.H. Kellogg was not a hereditary physician, his father had a factory in the town of Battle Creek (Michigan) for making brooms. But the young John refused to make brooms, he graduated from the Medical Department of New York University and for half a century (1877–1929) published many books about a healthy lifestyle and treatment. According to Dr. Kellogg, electric light baths 2–3 times a week were the means not only of treating many diseases and purifying the body of harmful substances but, along with vegetarianism, etc., a part of the correct way of life. His book on light therapy is available in the Internet today.

Dr. Kellogg had a portfolio of three-volume “Rational Hydrotherapy: A manual of the physiological and therapeutic effects of the hydratic procedures and the technique of their application in the treatment of disease” republished more than once, and a more frugal in a number of sheets work “The Art of Massage: Practical manual for the student, the nurse and the practitioner”. Both in 1901 (Fig. 5) and in 1914, when the advertisement of the Davidovich hospital was published, shown in Figure 7, and water treatment (hydrotherapy), and massage were included in the range of means at the disposal of B.I. Spivakov. Boris

Iosifovich, who had now risen to the position of the head of the water-electro-light-healing hospital, simply had to have these manuals as handbooks.

The author of the latter was a personality that was vivid and attractive in its own way, albeit ambiguous. So, John Kellogg with his brother Will invented and produced “Kellogg’s Corn Flakes”; the sensational advertising campaign of these breakfasts in women’s magazines has revolutionized the grocery. At the same time, Dr. D.H. Kellogg was religious to fanaticism and possessed the qualities of an excellent preacher.

Turning to the Davidovich hospital, we must add that in 1914, it already had an X-ray room, where the well-known in Kharkov roentgenologist Yu.A. Goldinger worked. By 1917, the hospital had its own chemical and bacteriological laboratory for analysis. Boris Spivakov certainly had a hand in expanding the services in these fields. In the city guide of 1917, he was designated as a specialist not only for internal and nervous diseases but already for physical methods of treatment.

B.I. Spivakov, like P.A. Litsyn, were permanent employees of the Davidovich hospital; other doctors who worked in it, were replaced from time to time, especially in the years of war (1904–1905 and 1914). They were random people who did not reveal their skills, and there is no sense in monitoring their personnel assets. Thus, before the onset of the World War, the resident physicians of the clinic were doctors N.F. Burrov and S.D. Fogelson (Fig. 7). But already in the guide

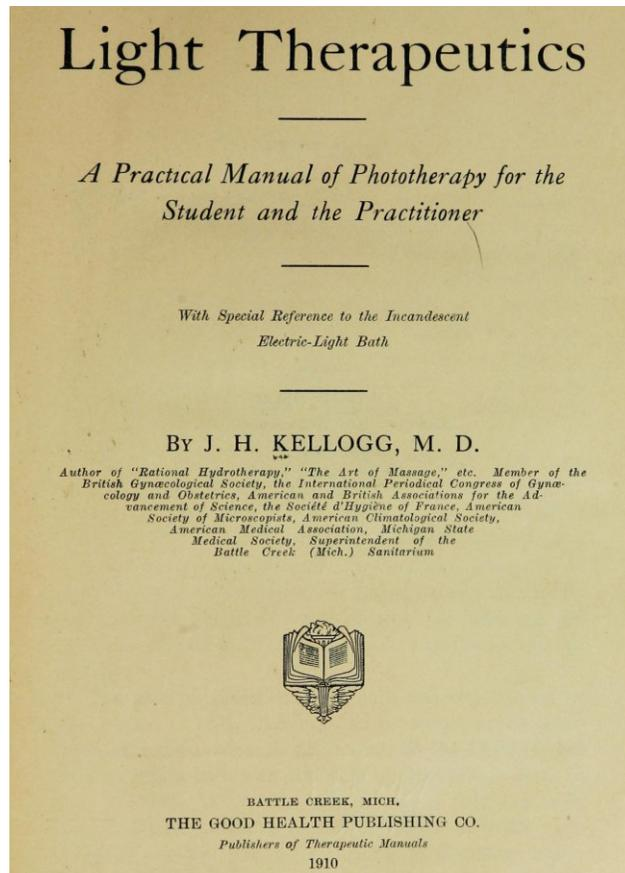

Fig. 6. American physician John Harvey Kellogg (left, source — Wikipedia) and title page of his work on light therapy (right)

Лѣчебница, водолѣчебница, электро-свѣто-лѣчебница и Рентгеновскій кабинетъ, учрежд. докторомъ

Г. А. ДАВИДОВИЧЕМЪ

Харьковъ, Благовѣщенская ул., соб. домъ № 10-12.

ПРИЕМЪ БОЛЬНЫХЪ СТАЦИОНАРНЫХЪ и ПРИХОДЯЩИХЪ.

Лѣчебница съ постоянными кроватями открыта для приема больныхъ нервными, сердечн., почечн., желудочно-кишечными, женскими заболѣван. и разстройствомъ обмѣна веществъ (ожиреніе, подагра, сахарное мочеизнуреніе и хроническій ревматизмъ). Въ лѣчебницу больные принимаются какъ для лѣченія, такъ и для всѣхъ видовъ изслѣдованія, а также для клиническ. наблюденій и консультацій, необходимыхъ зъ цѣляхъ діагноза и плана лѣченія.

Заразные, психич. и эпилептики вовсе не принимаются.

При лѣчебницѣ постоянное дежурство врачей.

Завѣд. лѣчебн. д-ръ П. А. Лищинъ. Ординат. лѣчебн. д-ра Н. О. Буровъ и С. Д. Фогельсонъ.

ВОДОЛѢЧЕБНИЦА

снабжена всѣми новѣйшими приспособленіями для гидро-бальнео-термотерапіи: въ томъ числѣ паровыя и суховоздушныя ванны, общія и частичныя (проф. Вieg'a), частичныя грязевыя ванны, минеральныя и углекислыя ванны, искусств. «Нарзанъ» и «Наугеймъ». Примѣненіе гидриатич. процедуръ производится подъ постояннымъ наблюденіемъ врача водолѣчебницы.

Водолѣчебница и электро-свѣтолѣчебница открыты круглый годъ.

Приемные часы для приходящихъ: мужчинъ отъ 8—10 ч. утра и 6—8 ч. веч., дамъ отъ 11—12 ч. дня и 4—6 ч. веч. Врачъ водо-электро-свѣто-лѣчебницы д-ръ Б. І. Спиваковъ.

ЭЛЕКТРО-СВѢТОЛѢЧЕБНИЦА

оборудована приборами для полученія токовъ. гальванич., фарадич., статич., синусоид., пульсиров., токовъ высокаго напряженія и большой частоты Тесла д'Арсонваля, апп. для диатерміи, приспособ. для гидро-электрич. ваннъ: двухнѣзд. и четырехнѣзд. системы д-ра Шнейа, а также аппаратами для мѣстнаго и общаго свѣтолѣченія.

Рентгеновскій кабинетъ снабженъ новѣйшими усовершенствованіями по діагностикѣ и терапіи. Приемъ больныхъ ежедневно 10—12 час. дня, 4—6 час. веч. въ экстренныхъ случаяхъ по соглашенію.

Завѣдующій рентгеновскимъ кабин. д-ръ Ю. А. ГОЛЬДИНГЕРЪ.

Отдѣльный кабинетъ для врачебной гимнастики и массажа: ручного и вибраціоннаго.

from them. According to the guide, Pavel Anatsayevich Litsyn worked in the Soviet hospital as an ordinary doctor; and Boris Iosifovich Spivakov remained in the then capital of the Ukrainian SSR, who was finally re-qualified as a physiotherapist. [8] Even the heir of the founder of the clinic, Alexander Grigorievich Davidovich, worked as a doctor for nervous diseases in the 4th working polyclinic at Pushkinskaya str., 32.

In the years of the NEP it was time to restore and repair the long-standing idle light and ordinary baths of the 3rd Soviet hospital. Probably not coincidentally in the neighborhood, on the Ekaterinoslavskaya street (now named after Y.M. Sverdlov) a private "electro-medical and mechanical workshop" was opened, which specialized just on physiotherapy electric appliances (Fig. 8). And advertising of the corresponding devices of German production returned to the medical periodical publications of the USSR, which greatly increased in the 1920s.

Fig. 7. Advertising of the hospital Davidovichey in the Kharkov Medical Journal (1914)

"All Kharkov in the pocket" for 1915, V.E. Filips and G.K. Nagel were named as the resident physicians.

The clinic of Davidovich, as it usually happens, only lost from the revolutions and the Civil War, both with the Reds and with the Whites. 19.08.1919, when the city was occupied by Denikin's army, local newspapers reported: "The thieves robbed the apartment of the famous Kharkov doctor A. Davidovich at Blagoveshchenskaya Street, 12. Property worth 65,000 rubles was stolen."

And the Bolsheviks, having occupied Kharkov at the end of the year, nationalized the clinic entirely, renamed it the 3rd working (Soviet) hospital for 40 beds. Despite this, the permanent staff of the clinic preferred cooperation with the expropriators to escape

It must be said that the Bolshevik government did not spare currency for the technical equipment of medicine and the development of science. As a result, in the second half of the 1920s the 3rd Soviet hospital gained deservedly the status of the "Physico-therapeutic institute" (as it was

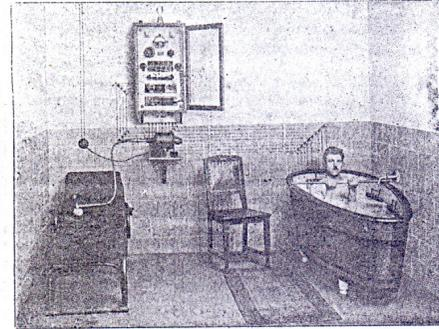

ЭЛЕКТРО-МЕДИКО-МЕХАНИЧЕСКАЯ МАСТЕРСКАЯ

В. С. ЛАПЕНКО

ХАРЬКОВ, улица Свердлова, № 22.

ВЫПОЛНЯЕТ ВСЕВОЗМОЖН. ЗАКАЗЫ ПО ОБОРУДОВАНИЮ

ЭЛЕКТРО-СВЕТОВОДО-ЛЕЧЕБНЫХЪ КАБИНЕТОВ

и отдельныхъ установокъ, какъ то:

СТАТИЧЕСКИЕ МАШИНЫ, СОЛЮКСЫ, СУХОВОЗДУШНЫЕ ВАННЫ (ЭЛЕКТРО-ТЕРМ. по д-ру Линденману) ВАННЫ 4-камери., РАСПРЕДЕЛИТ. ДОСКИ и т. д.

Fig. 8. Advertising from the Kharkov journal "Medical Practice" (1924)

written in the guides of that time) with an outpatient clinic, in other words, it became the Ukrainian Research Institute of Physiotherapy, which was described by Prof. L.D. Tondiy [1] in the article. That, of course, testified about the saved experience and authority of the medical institution which entered the period of maturity.

* * *

Today, the three-story building of the Davidovich's former clinic, which has not lost its external presentability for 120 years (Fig. 9), continues to serve health care: according to the signs, the Sanitary and epidemiological station of the Kharkov Line Department of the Southern Railway and the BAT (bioanalytical technologies) Medical Laboratory are located here. But physical methods of treatment are now not prescribed.

Since the thirties of the last century, there have been many changes that did not have the best effect on the status of the city (Kharkov ceased to be the first capital of the Ukrainian SSR, lost a number of scientific institutions, etc.), and the role of light therapy in medicine. For a long time, pharmacotherapy pushed aside the physical methods of treatment for the role of additional and auxiliary ones.

A huge gap in traditions between the time of the early rise of phototherapy in Kharkov and the current renaissance of photomedicine, which is now based on new sources of light and new forms of arranging medical treatment, has led to an almost complete loss of historical memory of the events of the 1890s–1920s and about the doctors who played a key role in these events.

Meanwhile, in our opinion, the activity of G.A. Davidovich, P.A. Litsyn and B.I. Spivakov should be carefully examined by current medical entrepreneurs; as the hospital on the Blagoveshchenskaya street developed successfully the physiotherapy course under the conditions of capitalism — the very one that since the 1990s was restored in the countries of the former USSR.

References

1. Tondiy LD. On the development of light-laser therapy in Slobozhanshchina. Fotobiol. ta fotomed. [Photobiol. and photomed.] 1998;1:126-30. (in Russian)
2. Rusanov KV, Rusanova EG. Berezovsky mineral waters in the 1860s. In: Materialy IV Mizhnar. nauk. internet-konf. Istorychni, ekonomichni, sotsialno-filosofski ta osvitchni aspekty rozvytku okhorony zdorovia [Materials of the IV Intern. scien. Internet conf. Historical, economical, socio-philosophical and educational aspects of health care development]; 2016 Nov 1-4; Kharkiv: Kolehium Publ.; 2016; p. 47-51; Rusanova EG, Rusanov KV. Lukyan Gurvich is a pioneer of the Berezovsky mineral waters. Ibid; p. 51-5. (in Russian)

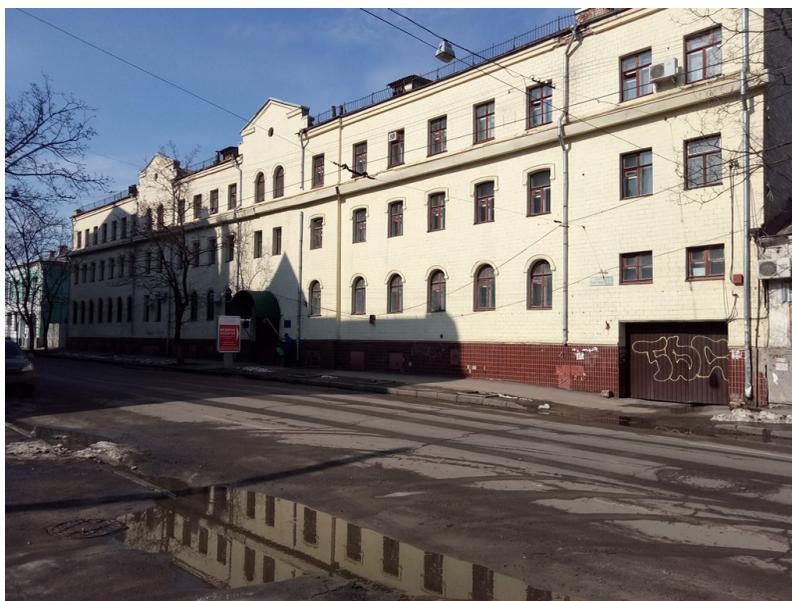

Fig. 9. The building of the former clinic of Davidoviche on the street. K. Marx (Blagoveshchensk), 10. Source: yandex.ua/maps

3. Rusanov KV, Rusanova EG. "Iron light" of Dr. Sudeikin: the history of phototherapy in Kharkov. In: Materialy 45-y Mezhdunar. nauchno-prakt. konf. Primenenie lazerov v meditsine i biologii [Materials of the 45th Internat. Scient. and Practic. Conf. Application of lasers in medicine and biology]; 2016 Oct 6-8; Harkiv-Bukovel. Harkiv: Petrov V.V. Publ.; 2016; p. 150-3. (in Russian)
4. Rusanov KV, Rusanova EG. The history of treatment with blue light in Kharkov. In: Materialy 44-y Mezhdunar. nauchno-praktich. konf. Primenenie lazerov v meditsine i biologii; 2016 May 26-28; Harkiv. Harkiv: Petrov V.V. Publ.; 2016; p. 133-6. (in Russian)
5. Robak IYu. Orhanizatsiia okhorony zdorovia v Kharkovi za imperskoi doby (pochatok XVIII st. – 1916 r.) [Healthcare Organization in Kharkiv during the Imperial Era Age (beginning of the 18th century – 1916)]. Kharkiv: Kharkov State Medical University Publ.; 2007. 346 p. (in Ukrainian)
6. Ustav chastnoy hirurgicheskoy lechebnitsyi s poliklinikoy doktora G.A. Davidovicha v g. Harkove [The charter of a private surgical hospital with a polyclinic of Dr. G.A. Davidovich in the city of Kharkov]. 1895. 7 p. (in Russian)
7. Anikin MM, Varserver GS. Osnovy fizioterapii: posobie dlya vrachey i studentov [Fundamentals of Physiotherapy: a guide for physicians and students]. Moscow - Leningrad: Biomedgiz Publ.; 1936. 722 p. (in Russian)
8. Spisok meditsinskih vrachey S.S.S.R. na 1 yanvarya 1924 g. [List of medical doctors of USSR on January 1, 1924]. Moscow: - Publ. of the People's Commissariat of Health, RSFSR; 1925. 827 p. (in Russian)
9. Meditsinskiy ukazatel g. Harkova [Medical guide of Kharkov]. The publication of the Blagoveshchensk pharmacy of S.B. Chudnovsky. Harkov; 1901. 82 p. (in Russian)
10. Zinchenko EK, Tondiy LD, Vasilyeva-Linetskaya LYa, Rozdiiskaya ON, Nechipurenko ON, Kas IS, et al. Department of Physiotherapy, Balneology and Restorative Medicine of the Kharkov Medical Academy of Postgraduate Education is 90 years. Shidnoevrop. zhurn. vnutrishnoyi ta simeynoyi med. [The Eastern Europ. Journal of Internal Med. and Family Med.]. 2017;2:54-61. (in Russian)

CLINICAL PHOTOMEDICINE

● **PHOTOBIOLOGY AND EXPERIMENTAL
PHOTOMEDICINE**

PHYSICS AND ENGINEERING IN PHOTOBIOLOGY
AND PHOTOMEDICINE

**MUTATIONS RATE IN DIFFERENT LINES OF *DROSOPHILA MELANOGASTER*
AFTER THE TREATMENT WITH CAFFEINE AND HE-NE LASER RADIATION**

O.V. Gorenskaya, N.S. Filiponenko, Yu.G. Shckorbatov

● **MORPHOLOGICAL SUBSTANTIATION OF THE USE OF LASER AND LED
IRRADIATION IN EMERGENT TREATMENT OF ULCER COMPLICATIONS**

I.M. Baybekov, D.T. Pulatov

● **ACCENTS OF THE HUMAN BODY ELECTROMAGNETIC BALANCE REGULATION
SYSTEM**

S.A. Gulyar

● **THERMAL PROCESSES IN HUMAN SKIN UPON IRRADIATION BY LASER
PULSES**

N.G. Kokodii, V.A. Timaniuk, A.M. Korobov

MUTATIONS RATE IN DIFFERENT LINES OF *DROSOPHILA MELANOGASTER* AFTER THE TREATMENT WITH CAFFEINE AND HE-NE LASER RADIATION

O.V. Gorenskaya

Cand. Sci. (Biol.), Assoc. Prof.
Dep. Genetics and Cytology
V.N. Karazin Kharkiv National University
4 Svobody Sq., Kharkiv, 61022, Ukraine
tel.: +38 (096) 971-83-99
e-mail: olgavg2014@gmail.com
ORCID: 0000-0003-0028-2522

N.S. Filiponenko

Senior Assistant
Dep. Genetics and Cytology
V.N. Karazin Kharkiv National University
4 Svobody Sq., Kharkiv, 61022, Ukraine
tel.: +38 (066) 611-07-03
e-mail: filiponenkon@gmail.com
ORCID: 0000-0002-8116-9101

Yu.G. Shckorbatov

Dr. Sci. (Biol.), Prof.
Dep. Molecular Biology and Biotechnology,
V.N. Karazin Kharkiv National University
4 Svobody Sq., Kharkiv, 61022, Ukraine
tel.: +38 (050) 401-58-57
e-mail: yuriy.shckorbatov@gmail.com
ORCID: 0000-0002-3315-0932

The frequency of dominant lethal mutations (DLM) after combined effect of caffeine (1,3,7-trimethylxanthine) and helium-neon laser radiation in *Drosophila* has been studied. Caffeine is a natural substance which is presented in many drinks, widely applied in medicine and reveals moderately toxic action and some mutagenicity/genotoxicity effects; red laser radiation is applied in medicine and can disrupt the processes of DNA and RNA biosynthesis. The aim of this work was to study the characteristics of the mutation process in *Drosophila melanogaster* under the influence of caffeine and red laser radiation, depending on the genotype.

We used wild type *Drosophila melanogaster* stocks *Canton-S* (*C-S*) and *Oregon* (*Or*), carrying an *ebony* mutation, respectively: *ebony_{C-S}* and *ebony_{Or}*; and mutant stock *ebony*. Control flies were grown in standard conditions, and in experiments with caffeine it was added in culture medium in concentration 0.5 mg/ml. Virgin flies were exposed to a helium-neon laser light (wavelength of 632,8 nm) with a surface power density of 0.03 mW/cm², the exposure time was 5 minutes.

The influence of caffeine causes an increase in the frequency of early DLM on 40% in mutant line *ebony*, and on 70.5% in the line *ebony_{C-S}*. Irradiation by light of helium-neon laser either reduces the incidence DLM, or has no effect in all lines used in this work. The simultaneous effect of two external factors induces diverse answers in different genotypes: it increases early DLM in line *C-S* and early and late DLM in line *ebony*; but has no effect in lines *ebony_{Or}* and *ebony_{C-S}*. The two-way analysis ANOVA F-test showed that the DLM frequency dependence impact of external factors is characterized by $F = 3.87$; of genotype $F = 5.14$; of the combined effects of genotype and external factors $F = 5.69$. The power of influence of external factors – 8.1%; of genotype 6.9%; and of the combined effects of the genotype and two external factors studied – 31.4%.

Conclusions. Irradiation with laser light had no mutagenic effect on *Drosophila*, and even revealed anti-mutagenic effect. Caffeine induced the DLM increase, but the combined caffeine and laser light impact increased DLM rate in line *ebony* and not influenced it in lines: *ebony_{Or}* and *ebony_{C-S}*.

Key words: dominant lethal mutations; *Drosophila* development; mutagenic effect; antimutagenic effect.

ОСОБЛИВОСТІ МУТАЦІЙНОГО ПРОЦЕСУ У РІЗНИХ ЛІНІЙ *DROSOPHILA MELANOGASTER* ЗА УМОВ СПІЛЬНОЇ ДІЇ КОФЕЇНУ І ВИПРОМІНЮВАННЯ HE-NE ЛАЗЕРУ

О.В. Горенська, Н.С. Філіпоненко, Ю.Г. Шкорбатов

Харківський національний університет імені В.Н. Каразіна, м. Харків, Україна

Досліджено частоту домінантних летальних мутацій (ДЛМ) у дрозофіли після спільного впливу кофеїну (1,3,7-триметилксантин) і гелій-неонового лазера. Метою даної роботи було вивчення особливостей мутаційного процесу у *Drosophila melanogaster* під впливом кофеїну і випромінювання гелій-неонового лазера в залежності від генотипу.

Експерименти проводили на лініях дикого типу *Drosophila melanogaster Canton-S* (*CS*) і *Oregon* (*Or*), які несуть мутантний ген *ebony*, і мутантної лінії *ebony*. Лінії були взяті з колекції ліній дрозофіли

кафедри генетики і цитології біологічного факультету Харківського національного університету імені В.Н. Каразіна. У контролі мух вирощували в стандартних умовах, у дослідах кофеїн додавали в середовище для культивування мух в концентрації 0,5 мг/мл. Віргіних мух піддавали впливу гелій-неонового лазерного випромінювання (632,8 нм) з щільністю потоку енергії 0,03 мВт/см² (тривалість впливу — 5 хвилин).

Результати роботи показали, що вплив кофеїну збільшує частоту ранніх ДЛМ на 40 % у мутантної лінії *ebony* і на 70,5 % у лінії *ebony_{c-s}*. Опромінення світлом гелій-неонового лазера призводить до зниження частоти ДЛМ. Одночасна дія зовнішніх чинників викликає різноспрямований ефект, залежний від генотипу досліджуваної лінії: збільшується частота ранніх ДЛМ у лінії *C-S* і ранніх і пізніх ДЛМ у лінії *ebony*. У ліній *ebony_{or}* і *ebony_{c-s}* рівень ембріональної смертності не відрізняється від контрольних значень. Двохфакторний дисперсійний аналіз показав, що частота ДЛМ визначається зовнішнім впливом ($F = 3,87$); генотипом ($F = 5,14$) і поєднаною дією зовнішніх і внутрішніх факторів ($F = 5,69$). Сила впливу зовнішніх факторів — 8,1%; генотипу 6,9%; спільної дії зовнішніх і внутрішніх факторів — 31,4%. Досліджена частота доміантних летальних мутацій у лінії дикого типу *Canton-S*, мутантної лінії *ebony* і ліній з заміщеним генотипом *ebony_{c-s}* та *ebony_{or}* при одночасній дії кофеїну (1,3,7-trimethylxanthine) і лазерного випромінювання. Показано, що сумарна частота виникаючих доміантних летальних мутацій залежить від усіх розглянутих у роботі факторів: від генотипу $F = 5,14$, від впливу досліджуваних зовнішніх факторів $F = 3,87$, і від поєднаної дії генотипу і зовнішніх факторів $F = 5,69$. В цьому випадку сила впливу генотипу склала 6,9%, зовнішніх факторів — 8,1% і поєднаної дії обох досліджуваних факторів — 31,4%.

Висновки. Опромінення лазерним випромінюванням не мало мутагенного ефекту на *Drosophila*, і навіть виявило антимутагенний ефект. Кофеїн викликав збільшення ДЛМ, але комбінований вплив кофеїну та лазерного випромінювання збільшив частоту ДЛМ у лінії *ebony* і не вплинув на частоту ДЛМ в лініях *ebony_{or}* та *ebony_{c-s}*.

Ключові слова: доміантні летальні мутації; розвиток дрозофіли; мутагенний ефект; антимутагенний ефект.

ОСОБЕННОСТИ МУТАЦИОННОГО ПРОЦЕССА У РАЗЛИЧНЫХ ЛИНИЙ *DROSOPHILA MELANOGASTER* ПРИ КОМБИНИРОВАННОМ ДЕЙСТВИИ КОФЕИНА И ИЗЛУЧЕНИЯ НЕ-НЕ ЛАЗЕРА

О.В. Горенская, Н.С. Филиппоненко, Ю.Г. Шкорбатов

Харьковский национальный университет имени В.Н. Каразина, г. Харьков, Украина

Исследована частота доминантных летальных мутаций (ДЛМ) у дрозофилы после совместного воздействия кофеина (1,3,7-триметилксантина) и гелий-неонового лазера. Целью данной работы было изучение особенностей мутационного процесса у *Drosophila melanogaster* под влиянием кофеина и излучения гелий-неонового лазера в зависимости от генотипа.

Эксперименты проводились на линиях дикого типа *Drosophila melanogaster Canton-S (C-S)* и *Oregon (Or)*, несущих мутантный ген *ebony*, и мутантной линии *ebony*. Линии были взяты из коллекции линий дрозофил кафедры генетики и цитологии биологического факультета Харьковского национального университета имени В.Н. Каразина. В контроле мухи выращивали в стандартных условиях, в опытах кофеин добавляли в среду для культивирования мух в концентрации 0,5 мг/мл. Виргинские мухи подвергались воздействию гелий-неонового лазерного излучения (длина волны 632,8 нм) с плотностью потока энергии 0,03 мВт/см² (время воздействия — 5 минут).

Результаты работы показали, что воздействие кофеина увеличивает частоту ранних ДЛМ на 40 % у мутантной линии *ebony* и на 70,5 % у линии *ebony_{c-s}*. Облучение светом гелий-неонового лазера приводит к снижению частоты ДЛМ. Сочетанное действие внешних факторов вызывает разнонаправленный эффект, зависящий от генотипа исследуемой линии: увеличивается частота ранних ДЛМ у линии *C-S* и ранних и поздних ДЛМ у линии *ebony*. У линий *ebony_{or}* и *ebony_{c-s}* уровень эмбриональной смертности не отличались от контрольных значений. Двухфакторный дисперсионный анализ показал, что частота ДЛМ определяется внешними воздействиями ($F = 3,87$); генотипом ($F = 5,14$) и сочетанием действия внешних и внутренних факторов ($F = 5,69$). Сила влияния внешних факторов — 8,1%; генотипа 6,9%; совместного действия внешних и внутренних факторов — 31,4%.

Выводы. Облучение лазерным светом не имело мутагенного эффекта на *Drosophila*, а также выявило антимутагенный эффект. Кофеин вызвал увеличение ДЛМ, комбинированное воздействие кофеина и лазерного излучения увеличило частоту ДЛМ в линии *ebony* и не повлияло на частоту ДЛМ в линиях *ebony_{or}* и *ebony_{c-s}*.

Ключевые слова: доминантные летальные мутации; развитие дрозофилы; мутагенный эффект; антимутагенный эффект.

Introduction

The studies of mutation rate in organisms in the process of their adaptation now become particularly relevant in relation to environmental issues. Caffeine is a natural substance which is presented in tea and coffee, is widely applied in medicine and reveals moderately toxic action and some mutagenicity/genotoxicity and carcinogenicity effects [1]. Radiation of helium-neon laser is applied in medicine and has many biological activities [2]. Among the basic model objects to study the mechanisms of influence on adaptive stress is *Drosophila*. The study of the mutation process of organisms in stressful conditions in relation to genotype is important for understanding the mechanisms of adaptation to adverse conditions and also in connection with differences in adaptive capacity of different genotypes.

Thus, the aim of this work was to study the characteristics of the mutation process in *Drosophila melanogaster* under the influence of caffeine and radiation of helium-neon laser, depending on the genotype.

Materials and methods

We used wild type *Drosophila melanogaster* lines *Canton-S* (*C-S*) and *Oregon* (*Or*), mutant line *ebony*, and also lines bearing *ebony* mutation which were obtained by saturating crosses of *ebony* line with lines *C-S* on *Or*, respectively: *ebony_{C-S}* and *ebony_{Or}*. All *Drosophila* lines were cultivated in standard culture vessels in sugar-yeast medium in an incubator at temperature of $23 \pm 0,5$ °C. Sorting flies by sex was performed on the first day after flies leaving the puparium. In the experiment were taken only virgin flies. The diethyl ether was used for narcotizing flies.

Control flies were grown in standard conditions and in experiments with caffeine it was added in culture medium in concentration 0.5 mg/ml. Virgin flies were exposed to a helium-neon laser red light (wavelength of 632.8 nm) with a surface power density of 0.03 mW/cm², the exposure time was 5 minutes. The experiment was done in two variants — after the development of flies in the medium with caffeine and after the development of flies in standard conditions.

The frequency of dominant lethal mutations (DLM) was assessed by a percentage of eggs that are not developed of the total number of fertilized eggs. Dead eggs were classified in two groups: the transparent and light opaque eggs — as bearing the early lethal mutations (death of the embryo occurred in the period up to 6–9 h of embryonic development); dark eggs — as bearing late lethal mutations (the death of the embryo occurred later 9 h of embryonic development) [3].

The statistical analysis was done using the program Biostat 2009 (AnalystSoft, USA). Statistical significance of differences between mean values was determined by the two-sided Student's t-test (at $P < 0,05$). Statistical significance and the power of factors was assessed using two-factor analysis of variance (ANOVA) by the Snedecor's method.

Results

The results of the study of early and late dominant lethal mutations frequency in mutant lines and wild-type *Drosophila* lines depending on the combined effects of caffeine and laser irradiation treatment are shown in Figures 1–4.

The influence of caffeine causes an increase in the frequency of early DLM on 40% in mutant line *ebony*, and on 70.5% — in the line *ebony_{C-S}* (Fig. 2, 3).

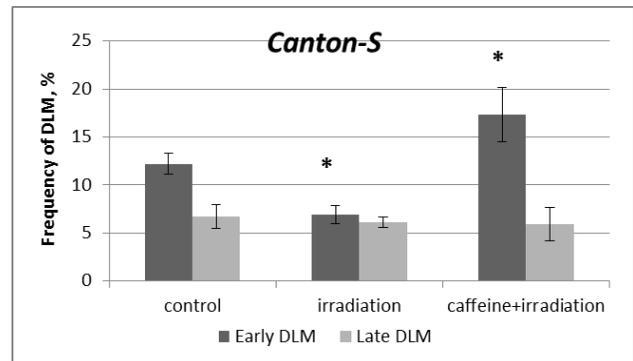

Fig. 1. Frequency of early and late DLM in wild type line *Canton-S*, depending on the action of caffeine and red laser light.

*Statistical significance of difference from control $P < 0.05$

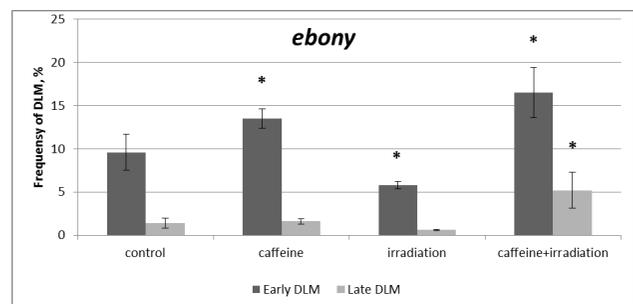

Fig. 2. Frequency of early and late DLM in line *ebony* after action of physical and chemical factors.

*Statistical significance of difference from control $P < 0.05$

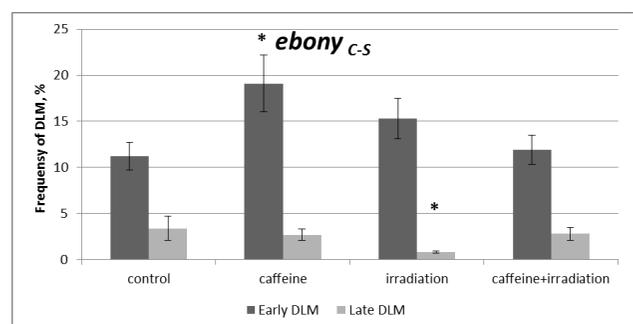

Fig. 3. Frequency of early and late DLM mutant line *ebony_{C-S}* after the action of physical and chemical factors.

*Statistical significance of difference from control $P < 0.05$

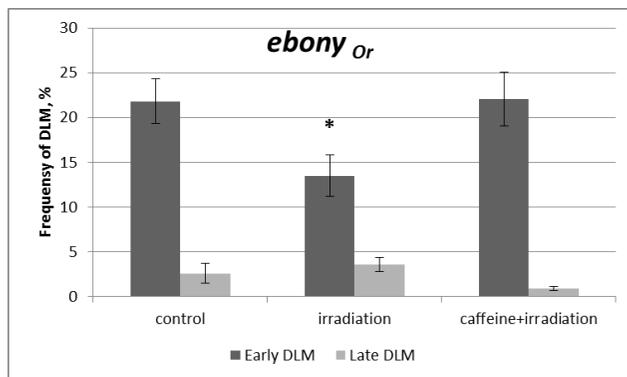

Fig. 4. Frequency of early and late DLM mutant lines *ebony_{Or}* after action of physical and chemical factors.

*Statistical significance of difference from control P<0.05

Irradiation by light of helium-neon laser either reduces the incidence DLM, or has no effect in all lines used in this work (Fig. 1–3). The simultaneous effect of two external factors induces diverse answers in different genotypes: it increases early DLM in line C-S and early late DLM in line *ebony*; but has no effect in lines *ebony_{Or}* and *ebony_{C-S}* (Fig. 1–4).

The total incidence of DLM after the combined influence of caffeine and laser irradiation in *Drosophila* depended on the genotype as shown in Fig. 5.

The two-way analysis ANOVA F-test showed that the DLM frequency dependence impact of external factors is characterized by F = 3.87; of genotype F = 5.14; of the combined effects of genotype and external factors F = 5.69. The power of influence of external factors – 8.1%; of genotype 6.9%; and of the combined effects of the genotype and two external factors studied – 31.4%.

Discussion

In the present work it was shown that the caffeine treatment of larvae is resulted with the increase of mutation incidence in *Drosophila* of lines *ebony*, *ebony_{C-S}*, and *ebony_{Or}* (Fig. 2–5). This result is consistent with obtained previous results indicating an increase in the frequency of DLM under chronic caffeine exposure in *Drosophila* mutant lines [4]. The main mechanism of action of caffeine is associated with the regulation of intracellular cAMP (cyclic adenosine monophosphate) levels, which is directly related to the change of calcium level in the cell. In addition, the effect of caffeine leads to a change in the conformation of the DNA molecule by embedding instead of or between the bases [5]. Our results are in a good agreement with known effects, for instance, caffeine cause mutagenic effects [6], and by violation of DNA repair induce accelerated aging [7].

The experimental data show that the laser light exposure never increases the DLM incidence, but vice versa, decreases it (Fig. 1–5). This result corresponds to conclusion of A. Budagovsky that the low-intensity laser irradiation of visible spectrum is not a mutagenic factor and its application does not involve the risk of genetic

modification of plants. The phenomenon that is regarded as a laser radiation mutagenesis is a result of the other processes, leading to the same consequences [8].

The *ebony* mutation is localized in chromosome 3 and causes darker body color in adults. Melanization in most organisms have an adaptive effect [9]. Thus, melanin, causing dark body color, involved in the formation of resistance in *Drosophila* by the action of different pathogens [10]. Melanins in animals are antioxidant pigments acting as free radical scavenging mechanisms [11]. But in our experiments the mutant line *ebony* not revealed more resistance to caffeine demonstrating that in this case the additional portion of melanin has no protective effect on caffeine-induced mutagenesis (Fig. 2, 3)

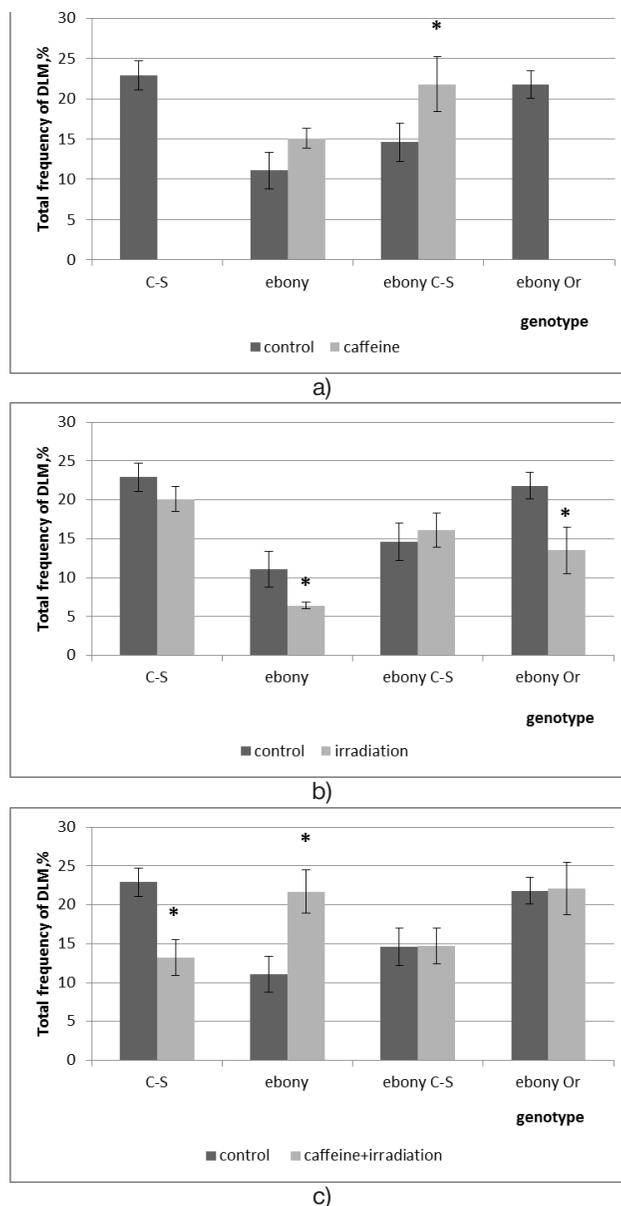

Fig. 5. The total frequency of DLM, % after the influence of caffeine (a), laser irradiation (b) and combined influence of caffeine and laser irradiation (c) in *Drosophila* depending on the genotype.

*Statistical significance of difference from control P<0.05

In our experiments the combined effects of caffeine and laser light induced increase in DLM rate only in the line of *Drosophila ebony*, but not in the line *Canton-S*. The DLM rate in mutant lines *ebony^{or}* and *ebony^{c-s}* not changed under the combined impact of caffeine and laser light. In our opinion this is connected with weakened “genetic background” of the line *ebony*.

Conclusion

Thus, the results show that laser light in our experiments had no mutagenic effect on *Drosophila*, and revealed antimutagenic effect. Caffeine induced the DLM increase. The incidence of dominant lethal mutations under combined caffeine and laser light impact increased in line *ebony* but was not influenced in the lines with mutant genotype saturated with genotypes of wild-type lines: *ebony^{or}* and *ebony^{c-s}*. ANOVA test revealed that the most impact on mutation rate variability had the effects connected with interaction of genotype and external factors — caffeine and laser light exposure.

References

1. Nawrot P, Jordan S, Eastwood J, Rotstein J, Hugenholz A, Feeley M. Effects of caffeine on human health. *Food Addit Contam.* 2003 Jan;20(1):1-30.
2. Farivar S, Malekshahabi T, Shiari R. Biological effects of low level laser therapy. *J Lasers Med Sci.* 2014;5(2):58-62.
3. Tikhomirova MM. *Geneticheskiy analiz: uchebnik [Genetic analysis: Textbook]*. Leningrad: Leningrad State University Publ.; 1990. 280 p. (in Russian).
4. Horenskaya OV. Formation of adaptivity to caffeine exposure in *Drosophila melanogaster*. *Bulletin of Kharkiv Karazin National University. Series: biology.* 2010; 10(905): 66-77.
5. Deriabina AS, Grokhlina TI, Polteva NA et al. Study of Mechanisms of Some Caffeine Biological Effects via Computer. *Simulation of Its Interactions with DNA Fragments. J. Mol. Struct. (Theochem).* 2006;769(1-3):97-101.
6. Clark AM, Clark EG. The genetic effects of caffeine in *Drosophila melanogaster*. *Mutation Research.* 1968; 6:227-34.
7. Nikitin AG, Navitskas S, Gordon LN. Effect of varying doses of caffeine on life span of *Drosophila melanogaster*. *J Gerontol: Biol Sci.* 2008;63A(2):149-50.
8. Budagovsky A. Does the low-intensity laser radiation have mutagenic effect? *Photonics.* 2013;38(2):114-27.
9. Cook LM, Turner JRG. Decline of melanism in two British moths: spatial, temporal and inter-specific variation. *Heredity*;2008;101:483-9.
10. Ayres JS, Schneider DS. A signaling protease required for melanization in *drosophila* affects resistance and tolerance of infections. *PLoS Biol.* 2008;6(12):2764-73.
11. Carletti G, Nervo G, Cattivelli L. Flavonoids and Melanins: A common strategy across two kingdoms. *Int J Biol Sci.* 2014;10(10):1159-70.

MORPHOLOGICAL SUBSTANTIATION OF THE USE OF LASER AND LED IRRADIATION IN EMERGENT TREATMENT OF ULCER COMPLICATIONS

I.M. Baybekov

*Dr. Sci. (Med.), Prof., Head of the laboratory
Laboratory of Pathological Anatomy
Republican Specialized Center of Surgery named after
academician V. Vakhidov
10 Farkhad St., Tashkent, 100115, Uzbekistan
tel.: +998 (71) 277-92-57
e-mail: baibekov@mail.ru
ORCID 0000-0003-0587-3188*

D.T. Pulatov

*Senior Researcher
Department of Emergency Surgery
Republican Scientific Center of Emergency Medical Care
2 Farkhad St., Tashkent, 100107, Uzbekistan
tel.: +998 (71) 150-46-00
e-mail: baibekov@mail.ru*

The structural basis of ulcer perforation and bleeding was determined, based on morphological evaluation of gastroduodenal ulcers. The effects of low-intensive laser irradiation LILI and LED irradiation on pathomorphosis of ulcers were studied. It was found that the local phototherapy with LILI and LED increases the relative fraction volume — RFV of fibroblasts and connective tissue fibers, reduces RFV of cell-free zones, which contributes to “strengthening” of the ulcer walls and prevents their perforation. These same photo-influences lead to an increase of RFV of blood vessels, indicating inappropriateness of their use for local phototherapy in bleeding ulcers.

Key words: gastroduodenal ulcers, morphology, perforation, bleeding, laser and LED irradiation.

МОРФОЛОГІЧНЕ ОБҐРУНТУВАННЯ ВИКОРИСТАННЯ ЛАЗЕРНОГО ТА СВІТЛОДІОДНОГО ВИПРОМІНЮВАННЯ В ЛІКУВАННІ УРГЕНТНИХ УСКЛАДНЕНЬ ВИРАЗКОВОЇ ХВОРОБИ

І.М. Байбеков¹, Д.Т. Пулатов²

*¹АТ «Республіканський спеціалізований центр хірургії імені академіка В.Вахідова»,
Міністерство охорони здоров'я Республіки Узбекистан, м. Ташкент, Республіка Узбекистан;
²Республіканський науковий центр екстреної медичної допомоги, м. Ташкент, Республіка Узбекистан*

На підставі морфологічної оцінки гастродуоденальних виразок встановлено структурні основи їх прободіння і виразкових кровотеч. Вивчено вплив на патоморфоз виразок низькоінтенсивного лазерного — НІЛВ і світлодіодного випромінювання — LED. Виявлено, що локальна фототерапія з використанням НІЛВ і LED збільшує відносну об'ємну частку — ВОЧ фібробластів і сполучнотканинних волокон, знижує ВОЧ безклітинних зон, що сприяє «зміцненню» стінок виразок, і попереджає їх прободіння. Ці ж фотовпливи призводять до збільшення ВОЧ кровоносних судин, що вказує на недоцільність їх використання для локальної фототерапії при виразкових кровотечах.

Ключові слова: гастродуоденальні виразки, морфологія, прободіння, кровотечі, лазерне і світлодіодне випромінювання

МОРФОЛОГИЧЕСКОЕ ОБОСНОВАНИЕ ИСПОЛЬЗОВАНИЯ ЛАЗЕРНОГО И СВЕТОДИОДНОГО ИЗЛУЧЕНИЯ В ЛЕЧЕНИИ УРГЕНТНЫХ ОСЛОЖНЕНИЙ ЯЗВЕННОЙ БОЛЕЗНИ

И.М. Байбеков¹, Д.Т. Пулатов²

*¹АО «Республиканский специализированный центр хирургии имени академика В. Вахидова»,
Министерство здравоохранения Республики Узбекистан, г. Ташкент, Республика Узбекистан;
²Республиканский научный центр экстренной медицинской помощи, г. Ташкент, Республика Узбекистан*

На основании морфологической оценки гастродуоденальных язв установлены структурные основы их прободения и язвенных кровотечений. Изучено влияние на патоморфоз язв низкоинтенсивного лазерного — НИЛИ и светодиодного излучения — LED. Выявлено, что локальная фототерапия с использованием НИЛИ и LED увеличивает относительную объёмную долю — ООД фибробластов и соединительнотканых волокон, снижает ООД бесклеточных зон, что способствует «укреплению» стенок язв, и предупреждает их прободение. Эти же фотовоздействия приводят к увеличению ООД кровеносных сосудов, что указывает на нецелесообразность их использования для локальной фототерапии при язвенных кровотечениях.

Ключевые слова: гастродуоденальные язвы, морфология, прободения, кровотечения, лазерное и светодиодное излучение

Background and objectives

Marked trend in decrease of the number of patients with peptic ulcer disease requiring surgical treatment, due to the development of the “gold standard” of drug therapy of this disease, based on the discovering etiological and pathogenetic role of *Helicobacter pylori*. [1-4]

Despite this, peptic ulcer disease – PUD continues to be one of the most urgent problems of surgery. Prevalence of PUD among adult population comprises 6–10%. A significant proportion of patients with PUD need emergent treatment. This is especially true of its complicated forms. [2,3,5-12]

Various types of photo-influencing such as local irradiation of ulcers, using low-intensive lasers – LIL, and more recently, LED (Light Emitting Diode) light and intravascular laser irradiation of blood – ILIB widely used in gastroenterology, including complex treatments of urgent complications of ulcers. [1,7,13-18]

However, morphological grounds of expediency of using particular types of photo-influencing and methods for their use in the treatment of urgent complications of ulcers are not clear enough.

This has determined the objectives of study: to provide morphological justification for reasonability of using LIL and LED in complex treatment of bleeding and perforations of gastroduodenal ulcers.

Material and Methods

The followings were studied with aid of light, electron microscopy and stereomorphometry: uncomplicated gastric ulcers – 20, perforated gastric ulcers – 20, bleeding gastric ulcers before and after phototherapy – 18; 10 uncomplicated and 14 bleeding duodenal ulcers. Along with this, we also considered the presence of so-called microcollectors in ulcer walls and peri-ulcerous areas, which are the structural basis of persistent ulcers. (Scient. discovery: “The phenomenon of infiltration of gastric juice through defect in gastric and duodenal wall in patients with PUD” priority date 6.02.1991 № OT-12119).

The tissue samples used for morphological study were excised from the edges of ulcers during surgery. After the course of phototherapy biopsy samples were obtained during fibrogastroduodenoscopy.

Archival microscopic specimens of pathology laboratory of RSCS after acad. V.Vakhidov were used for studying uncomplicated ulcers.

For light microscopy, tissue was fixed in 10–12% formalin solution on phosphate buffer by Lilly. Paraffin sections were stained with hematoxylin-eosin.

For transmission electron microscopy (TEM), tissue samples were fixed with 2.5% glutaraldehyde solution on phosphate or cacodylate buffer, after dehydration in alcohol and acetone embedded in epon–araldite mixture. Ultrathin sections were obtained on

ultratome “Ultracut”, contrasted in “Ultrastainer” and examined with Hitachi H-600 electron microscope.

For scanning electron microscopy (SEM), the specimens, after the above-described fixation and dehydration were then dried by critical point drying in HCP-2, after which gold sputtered with IB-2 and examined in microscope JEOL JSM-6010LV and Hitachi- S405.

Stereomorphometric studies were carried out according to G. Avtandilov. [19] This method was modified and adapted for morphometry of objects on the computer screen with a transparent film, containing marks potted on it. For purposes of studying the discrete structures each cell was lined out 100 marks. Linear structures were studied by using micrometer bar “OMO” with the scale range of 1000 mm and a scale division of 0.01 mm, projected on film.

Statistical analysis was performed on a PC with “BS – Statistica” software, as well as MS Excel application.

Epigastric areas in the projection of ulcers were irradiated with laser percutaneously, (“Mustang 017-MCS-PC”, magnetic nozzle with magnetic field strength of 50 MLT), for 5 minutes at 1000 Hz on daily basis, 5 sessions in total.

Percutaneous LED irradiation was performed with LED set “Barva-Flex/BIR”, (12 blue (470 nm) and 12 infrared (940 nm) emitters, the radiation power of each LED equaling to 5 mW) in projection of uncomplicated ulcers, daily for 7–10 min over the time of 5–7 days under conditions of maximum proximity to the skin surface.

Results

Comparative stereomorphometric studies of uncomplicated gastric ulcers, duodenal ulcers and gastric ulcers complicated by perforation, showed a significant increase in the relative volume fraction – RVF of cell-free zones, thin-walled capillaries and lymph microcollectors (Table 1, Fig. 1.3). Light microscopy as well as SEM and TEM demonstrate presence of RBC - predominantly pathologic deformed forms, and other blood cells in the lumen of latter (Fig. 1, 3, 4).

A significant increase in RVF of fibroblast is noted after courses of percutaneous exposure of uncomplicated gastric ulcers to LILI and LED, with significant decrease of RVF of microcollectors and intercellular spaces. These changes are accompanied by a pronounced increase in the RVF of blood vessels (Table 1).

Photo-influencing in case of complicated by perforation ulcers have also showed a significant increase of RVF of fibroblasts and blood vessels, reduction of intercellular spaces, lymph vessels and microcollectors (Table 1).

Earlier conducted similar studies of perforated duodenal ulcers showed similar results [15].

Light microscopic and stereomorphometric studies of bleeding gastric and duodenal ulcers demonstrated

a significant increase in RVF of blood vessels in this type of complication (Table 2, 3, Fig. 2, 3).

RVF of blood vessels in bleeding gastric ulcers increases 5 times, lymphatic vessels 4 times, microcollectors – 1.3 times. In duodenal bleeding ulcers RVF of blood vessels increases more than 4 times, lymph capillaries more than 5 times, microcollectors 1.5 times

(Table 1, 2, Fig. 1, 2). It was found that such increase of RVF of blood vessels after courses of phototherapy is also characteristic for uncomplicated gastric and duodenal ulcers (as previously mentioned). This, in our view, indicates the inexpedience of usage of photo-influences in ulcers that are prone to bleeding, i. e. have high RVF of blood vessels and microcollectors.

Table 1

Cellular composition of fibrinoid necrosis areas and granulation tissue taken from the edges of perforated gastric ulcers and peri-ulcerous areas (in relative volume fraction, %)

Cellular composition of stroma	Uncomplicated ulcers (n=20)	Perforated ulcers (n=20)	Uncomplicated ulcers after LED-therapy (n=10)	Uncomplicated ulcers after LILI-therapy (n=10)	Perforative ulcers after LED-therapy (n=10)	Perforative ulcers after LILI-therapy (n=10)	
Plasma cells	8.0 ± 0.2	7.4 ± 0.3	6.8 ± 0.02	6.5 ± 0.2*	6.6 ± 0.2*	6.4 ± 0.2**	
Lymphocytes	8.8 ± 0.3	7.6 ± 0.2	7.5 ± 0.02	7.2 ± 0.2	7.2 ± 0.2	7.0 ± 0.2*	
Must cells	2.6 ± 0.1	1.9 ± 0.1	2.2 ± 0.1	2.1 ± 0.1	2.2 ± 0.1	2.0 ± 0.1	
Eosinophils	5.0 ± 0.2	4.8 ± 0.2	5.1 ± 0.2	4.9 ± 0.2	5.1 ± 0.2	5.0 ± 0.2*	
Segmented neutrophils	2.1 ± 0.1	1.8 ± 0.2	1.5 ± 0.1	1.4 ± 0.1	1.4 ± 0.1	1.3 ± 0.1	
Macrophages	0.9 ± 0.1	1.0 ± 0.1	0.8 ± 0.1	0.9 ± 0.1	0.8 ± 0.1	0.8 ± 0.1	
Fibroblasts+fibers	6.6 ± 0.2	2.0 ± 0.2*	10.9 ± 0.2**	11.9 ± 0.2**	11.5 ± 0.2**	12.4 ± 0.2**	
Vessels	blood	1.2 ± 0.02	1.2 ± 0.02	6.2 ± 0.2**	7.0 ± 0.02	6.2 ± 0.02	6.4 ± 0.02
	lymphatic	0.7 ± 0.03	1.5 ± 0.02*	0.5 ± 0.02	0.5 ± 0.02	0.5 ± 0.02	0.5 ± 0.02
Microcollectors	8.7 ± 0.4	10.6 ± 0.8	7.2 ± 0.4**	7.0 ± 0.4**	7.3 ± 0.4**	7.2 ± 0.4**	
Intracellular substance	52.5 ± 0.9	59.2 ± 1.0*	49.4 ± 0.8**	49.2 ± 0.8**	49.4 ± 0.8**	49.2 ± 0.8**	
Others	2.9 ± 0.1	1.0 ± 0.2	1.9 ± 0.1	1.4 ± 0.1	1.8 ± 0.1	1.8 ± 0.1	

* reliable in relation to uncomplicated ulcers ($p < 0,05$)

** reliable in relation to perforated ulcers ($p < 0,05$)

Table 2

Cellular composition of fibrinoid necrosis areas and granulation tissue from bleeding gastric ulcers (in relative volume fraction, %)

Cellular composition of stroma	Uncomplicated ulcers (n=20)	Bleeding ulcers (n=18)
Plasma cells	8.0 ± 0.2	7.4 ± 0.3
Lymphocytes	8.8 ± 0.3	8.9 ± 0.2
Mast cells	2.6 ± 0.1	4.2 ± 0.1*
Eosinophils	5.0 ± 0.2	6.0 ± 0.2
Segmented neutrophils	2.1 ± 0.1	3.2 ± 0.2
Macrophages	0.9 ± 0.1	2.2 ± 0.1*
Fibroblasts + fibers	6.6 ± 0.2	6.2 ± 0.2
Vessels	blood	1.2 ± 0.02
	lymphatic	0.5 ± 0.03
Microcollectors	9.9 ± 0.4	12.8 ± 0.8*
Intercellular substance	52.5 ± 0.9	38.4 ± 1.0*
Others	1.9 ± 0.1	2.8 ± 0.2

* reliable in relation to uncomplicated ulcers ($p < 0.05$)

Table 3

**Cellular composition of fibrinoid necrosis and granulation tissue from duodenal ulcers
(in relative volume fraction, %)**

Cellular composition of stroma		Uncomplicated ulcers (n=10)	Bleeding ulcers (n=14)
Plasma cells		8.1±0.2	7.2±0.3
Lymphocytes		8.9±0.3	10.9±0.2
Mast cells		2.4±0.1	4.4±0.1*
Eosinophils		5.1±0.2	6.6±0.2
Segmented neutrophils		1.8±0.1	3.0±0.2*
Macrophages		0.8±0.1	1.9±0.1*
Fibroblasts+fibers		6.4±0.2	7.2±0.2
Vessels	blood	1.6±0.02	7.0±0.3*
	lymphatic	0.4±0.03	2±0.1*
Microcollectors		8.4±0.4	12.6±0.8*
Intercellular substance		53.4±1.0	34.3±1.0*
Others		2.7±0.1	2.9±0.2

* reliable in relation to uncomplicated ulcers (p<0.05)

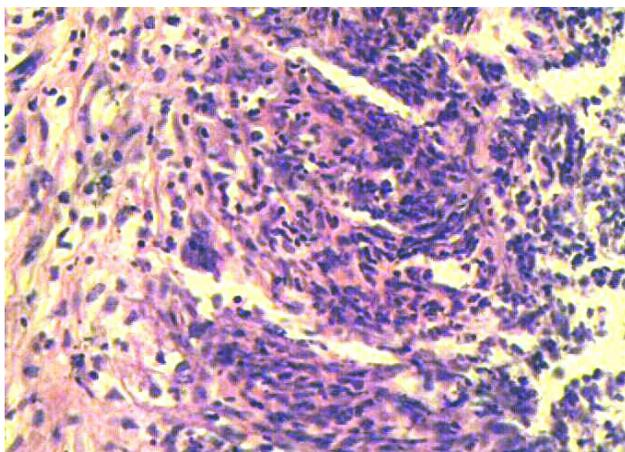

Fig. 1. Well discernable microcollectors with cells in their lumen and microvessels. Edge of bleeding ulcer. H&E 10x40

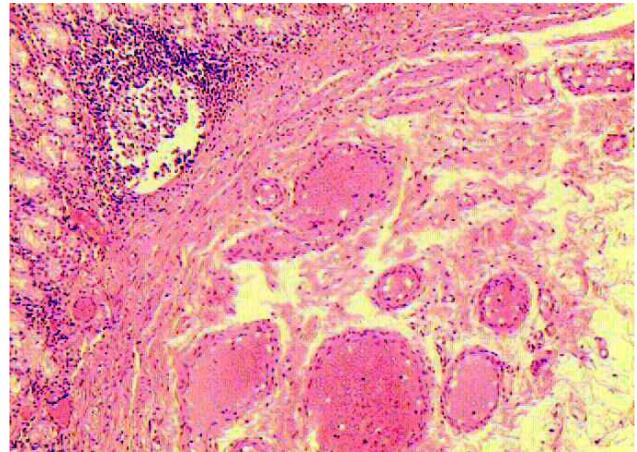

Fig. 2. Predominance of blood vessels. Cell-free zones and dilated lymphatic capillaries. Edge of bleeding ulcer. Г-Э 10x10

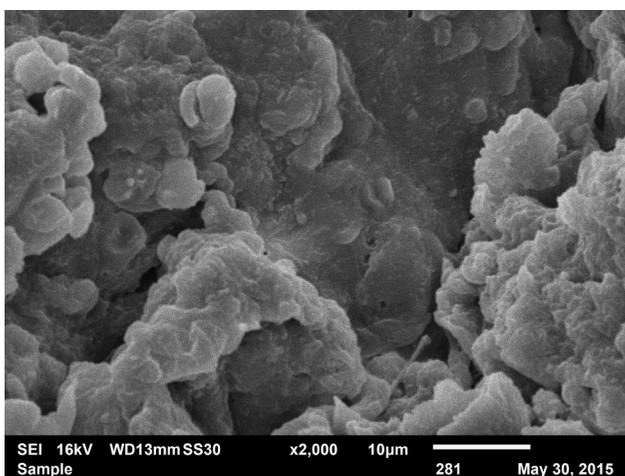

Fig. 3 Opening of microcollectors with RBC in their lumen. Edge of bleeding gastric ulcer. SEM x2000

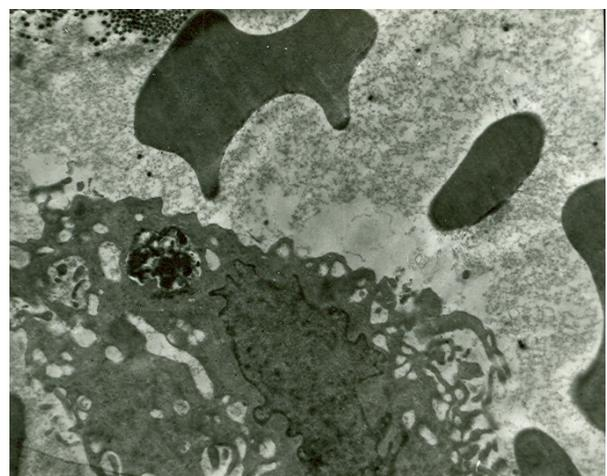

Fig. 4. Deformed RBC in cell-free spaces (microcollectors) from an edge of bleeding duodenal ulcer. TEM x 7500

Discussion

Laser, and in recent years LED light are widely used in practically all branches of medicine. Moreover, studies show that, as a rule, the efficiency of LILI is comparable to LED. [1,13-15,18] Gastroenterology, in this respect, is no exception. In particular, various kinds of photoexcitation widely used in treatment of peptic ulcers, and primarily, uncomplicated gastroduodenal ulcers. [1,15] Carried out, in the mid 90-ies of the last century, studies have shown positive effects of LILI on the healing of uncomplicated ulcers. The morphological studies have established that the structural basis of such positive effects lie in reduction of inflammatory changes, stimulation of cell proliferation and differentiation, provided by improvement of microcirculation due to increase of RVF of blood vessels and fibroblasts. [1]

Less frequently LILI and LED are exploited in the treatment of complicated ulcers and, above all, the so-called acute complications. This is partly due to the lack of clear criteria, and above all the morphological, to justify the use of phototherapy in the treatment of such urgent complications of gastroduodenal ulcers as bleeding and perforation.

The conducted comparative stereomorphometric study of uncomplicated gastroduodenal ulcers and ulcers, complicated by perforation and bleeding, revealed some structural features that, in our view, should be considered in using phototherapy for urgent complications of gastroduodenal ulcers.

In this way, perforation of ulcers is associated with substantial increases of RVF of structureless areas and thin-walled lymphatic vessels. It is also accompanied by a marked reduction of fibroblasts and fibrous components. Bleeding ulcers are, on the other hand, associated with significant increase of RVF of blood vessels. Not the least of the factors in the emergence and persistence of gastroduodenal ulcers is amount of so-called microcollectors. [20,21]

Phototherapy of uncomplicated ulcers as with LILI as well as LED, results in a significant reduction of RVF of cell-free zones, thin-walled capillaries and lymph microcollectors, with increase of RVF of fibroblasts, fibrous structures and blood vessels. The same trend was observed in perforated ulcers.

This suggests that the use of local phototherapy can be useful in perforated ulcers.

An increase of RVF of blood vessels observed after local phototherapy may predispose to bleeding. Therefore, the use of local phototherapy in bleeding ulcer, which is associated with increased RVF of blood vessels, does not seem to be rational. Phototherapy in case of bleeding ulcers can be limited to use of ILIB – an effective mean in correcting red blood cells, the majority of which become deformed and acquire pathologic forms in bleeding. [1,13,14,17]

Conclusions

1. Perforated ulcers are characterized by high RVF of thin-walled lymph capillaries and cell-free zones; the RVF fibroblasts and fibers becomes reduced, which is a structural basis of this complication. Phototherapy reduces the RVF of acellular zones and increases the RVF of fibroblasts and fibers, which indicates the desirability of its use in the urgent complications.

2. Bleeding ulcers are characterized by the fact that they contain increased RVF of blood vessels. Phototherapy of uncomplicated ulcers leads to an increases of RVF of blood vessels. This implies that the use of photoexcitation in bleeding ulcers is not advisable.

3. The morphological study of biopsies from the edges of ulcers and peri-ulcerous areas should play a decisive role in the administering phototherapy in urgent complications of peptic ulcer disease.

References

1. Baibekov IM, Nazirov FG, editors. Morfologicheskie aspekty lazernyih vozdeystviy (na hronicheskie yazvy i pechen) [Morphological aspects of laser influences (on chronic ulcers and liver)]. Tashkent: Ibn Sina Publ.; 1996. 207 p. (in Russian)
2. Ivashkin VT. Gastroenterologiya [Gastroenterology]. Moscow: GEOTAR-Media; 2013. 704 p. (in Russian)
3. Ivashkin VT. Gastroenterologiya. Natsionalnoe rukovodstvo [Gastroenterology National guidelines]. Moscow: GEOTAR-Media; 2014. 480 p. (in Russian)
4. Zuo Jian-sheng, Xu Ke-cheng. The treatment and follow-up of the peptic ulcer associated with *Helicobacter pylori*. Ital J Gastroenterol. 1991;23(9):296.
5. Astashov VL, Kalinin AV. Bleeding from chronic gastroduodenal ulcers: diagnosis, tactics and surgical treatment. Klin. perspektivy gastroenterol., gepatologii [Clin. Prospects of Gastroenterology and Hepatology]. 2002;1:16-23. (in Russian)
6. Afendulov SA, Zhuravlev GYu. Hirurgicheskoe lechenie bolnyih yazvennoy boleznyu [Surgical treatment of patients with peptic ulcer]. Moscow: GEOTAR-Media; 2008. 336 p. (in Russian)
7. Korobov AM, Korobov VA, Lesnaya TA. Fototerapevicheskie apparaty Korobova serii "Barva" [Korobov's phototherapeutical devices of "Barva" series]. Harkiv: Petrov VV Publ.; 2010. 176 p. (in Russian)
8. Barkun A, Bardou V, Marshall JR, Nonvariceal Upper GI Bleeding Consensus Conference Group. Consensus Recommendations for Managing Patients with Nonvariceal Upper Gastrointestinal Bleeding. Ann Intern Med. 2003; 139(10):843-57.
9. De Caestecker J. Upper Gastrointestinal Bleeding: Surgical Perspective. Medicine from WebMD, Article Last Updated. 2006 Apr;11:89-91.
10. Hillakivi T, Lang A, Tein A. Evaluation of risk factors for mortality in surgical treated perforated duodenal ulcer. Hepatogastroenterology. 2000;47(36):1765-8.
11. Nogueira C, Silva AS, Santos JN, Silva AG, Ferreira J, Matos E, et al. Perforated peptic ulcer: main factors of morbidity and mortality. World J Surg. 2003 Jul;27(7):782-7.
12. Kang JY, Elders A, Majeed A, Maxwell JD, Bardhan KD. Recent trends in hospital admissions and mortality

- rates for peptic ulcer in Scotland 1982–2002 *Aliment Pharmacol Ther.* 2006 Jul 1;24(1):65-79.
13. . Baibekov IM, Mavlyan-Hodzhaev RSh, Erstekis AG, Moskvin SV. Eritrotsity v norme, patologii i pri lazernyih vozdeystviyah [Red blood cells in norm, pathology and in laser irradiation]. Tver: Triada Publ.; 2008. 255 p. (in Russian)
 14. . Baibekov IM, Ibragimov AF, Baibek-Palmos MI. Lazernyie vozdeystviya na kozhu i eritrotsity v norme i patologii [Laser influences on skin and red blood cells in health and disease]. Saarbrücken: LAMBERT Academic Publ.; 2014. 362 p. (in Russian)
 15. Baibekov IM, Pulatov DT. Effect of LED apparatus “Barva-Flex/SIK” on morphology of duodenal ulcers in terms of prevention of perforation. *Fotobiol. ta fotomed.* [Photobiol. and Photomed.]. 2014;12(3, 4):49-53. (in Russian)
 16. Heinz AV, Moskvin SV, Azizov GA. Vnutrivennoe lazernoe obluchenie krovi [Intravenous laser irradiation of blood]. Moscow: Triada Publ.; 2006. 144 p. (in Russian)
 17. Heinz AV, Moskvin SV. New technologies of intravenous laser irradiation of blood, “ILIB UVIB” and “ILIB-405”. *Materialy nauch.-prakt. konf. s mezhdunar. uch. Lazernaya meditsina XXI veka* [Materials of sc.-pract. conf. with internat. partic. Laser Medicine of the XXI century]; 2009 June 9-10; Moscow. p. 71. (in Russian)
 18. Tuner J, Hode L. *The New Laser Therapy Handboor.* Grängesberg: Prima book. 2010. 849 p.
 19. Avtandilov GG. Problemy patogeneza i patologoanatomicheskoy diagnostiki v aspektah morfometrii [Problems of pathogenesis and morphologic diagnosis in aspects of morphometry]. Moscow: Medicine Publ.; 1984. 436 p. (in Russian)
 20. Hadzhibayev AM, Eshbekov M, Baibekov IM, Mirzakhmedov BM. Possible mechanisms of morphogenesis of chronic ulcers of stomach and duodenum. *Med. zhurn. Uzbekistana* [Med. Jour. of Uzbekistan]. 1992;9-10:15-8. (in Russian)
 21. Hadzhibayev AM, Malikov YuR, Melnyik IV. Surgical tactics in the treatment of recurrent ulcer bleeding. Review of literature. *Byull. assots. vrachey Uzbekistana* [Bull. of physicians of Uzbekistan]. 2005;3:42-5.

ACCENTS OF THE HUMAN BODY ELECTROMAGNETIC BALANCE REGULATION SYSTEM

S.A. Gulyar

*Dr. Sci. (Med.), Prof., Leading Researcher
A.A. Bogomolets Institute of Physiology of NASU
4 Bogomoletz St., Kyiv, 01024, Ukraine
International Medical Innovation Center, Kiev, Ukraine
tel.: +38 (050) 411-16-32
e-mail: gulyar@zepter.ua
ORCID 0000-0003-2128-7656*

The presented analytical review includes data about the current state of knowledge on the electromagnetic ecological background influencing all living organisms. It is demonstrated that a non-specific morbidity can result from an electromagnetic imbalance and free-radical overloading resulting from disturbed ecology. We postulate the existence of a separate functional system of the electromagnetic regulation in the organism, and a working concept of phototherapy application is formulated. It is based on the possibility of using acupuncture points for energy compensation from electromagnetic waves of a biologically necessary range in the system of their conductors in the organism. This system can be considered as a tool for transmitting polarized electromagnetic waves in a visible light range.

Organs subjected to an electromagnetic imbalance because of an excess of the biologically inadequate irradiations and serving as targets for peroxidation-induced influences, i.e., neurohormonal and immune regulatory systems of the organism, are qualified as recipient zones. Subsequent electromagnetic stimulation or modification of the functions of the recipient zones result in positive curative effects; combination of the latter with local reparative processes allows one to provide positive clinical shifts in persons subjected to the respective treatment.

Natural possibilities allowing one to compensate deficiency in electromagnetic waves of the “solar” range are limited. Applications of PILER-light generated by BIOPTRON-type devices can be considered an adequate alternative. Combined application of local and systemic electromagnetic influences of the waves of a biologically necessary (visible light) range with the use of the principles of light therapy concepts constitutes a crucial feature of the modern approach.

At present, problems of judicial and medical legalization of light- and color therapy, questions of the main mechanisms of the effects of PILER-light, a field of the medical reasons for its application, first generations of the curative modes, and color therapy curative programs can be considered settled.

Among outstanding questions, in general directed toward the expansion of application of the PILER-light therapy technologies, the first place is occupied by a necessity for the development of new experimentally grounded curative programs and antipain techniques provided by color therapy.

Key words: BIOPTRON, PILER-light, electromagnetic waves, electromagnetic technology, electromagnetic imbalance, phototherapy, color therapy, polarized light, acupuncture points, energetical meridians, pain, immunity, visceral systems

АКЦЕНТИ СИСТЕМИ РЕГУЛЮВАННЯ ЕЛЕКТРОМАГНІТНОГО БАЛАНСУ ОРГАНІЗМУ ЛЮДИНИ

С.О. Гуляр

*Інститут фізіології ім. О.О.Богомольця НАН України, м. Київ, Україна
Інтернаціональний медичний інноваційний центр, м. Київ, Україна*

Наведено аналітичний огляд, що містить сучасний стан знань про вплив електромагнітного екологічного тла на живі організми. Встановлено, що неспецифічна захворюваність є результатом наслідком електромагнітного дисбалансу і вільнорадикальних переважань (інтоксикацій) — двох основних комплексів екологічних факторів.

Сформульована робоча концепція світлотерапії, згідно з якою точки акупунктури можуть бути використані для поповнення енергії від біологічно необхідних електромагнітних хвиль. Подальший їх транспорт здійснюється через спеціальні провідні шляхи (електромагнітний каркас). До органів-одержувачів віднесені органи, які відчувають електромагнітний дисбаланс в зв'язку з надлишком негативних випромінювань, інтоксикаційним переваженням вільними радикалами — нейрогормональна і імунна

системи організму. Відновлення їх стану забезпечує лікувальний ефект, а з урахуванням місцевих регенеративних процесів в зоні освітлення, він стає найбільшим. Можливості поповнення дефіциту сонячної енергії обмежені, повноцінним її замінником є ПАЙЛЕР-світло, створене апаратом БІОПТРОН.

Особливості сучасного підходу до світлотерапії полягають в комбінованому застосуванні місцевого і системного (через точки акупунктури) електромагнітного впливу ПАЙЛЕР-світлом. На теперішній час світло- і колортерапія отримали фізичне визнання, визначені основні механізми дії ПАЙЛЕР-світла, покази та лікувальні режими його застосування. Подальший пошук спрямований на розширення застосування ПАЙЛЕР-світлотерапевтичних технологій, зокрема, зі створення нових лікувальних програм і розробці протибольових методик колортерапії.

Ключові слова: БІОПТРОН, ПАЙЛЕР-світло, електромагнітні хвилі, електромагнітні технології, електромагнітний дисбаланс, світлотерапія, колортерапія, поляризоване світло, точки акупунктури, енергетичні меридіани, біль, імунітет, вісцеральні системи

АКЦЕНТЫ СИСТЕМЫ РЕГУЛЯЦИИ ЭЛЕКТРОМАГНИТНОГО БАЛАНСА ОРГАНИЗМА ЧЕЛОВЕКА

С.А. Гуляр

*Институт физиологии им. А.А.Богомольца НАН Украины, г. Киев, Украина
Интернациональный медицинский инновационный центр, г. Киев, Украина*

Представлен аналитический обзор, включающий современное состояние знаний о влиянии электромагнитного экологического фона на живые организмы. Установлено, что неспецифическая заболеваемость является результирующим следствием электромагнитного дисбаланса и свободно радикальных перегрузок (интоксикаций) — двух основных комплексов экологических факторов.

Сформулирована рабочая концепция светотерапии, согласно которой точки акупунктуры могут быть использованы для восполнения энергии от биологически необходимых электромагнитных волн. Дальнейший их транспорт осуществляется через специальные проводящие пути (электромагнитный каркас). К органам-получателям отнесены органы, испытывающие электромагнитный дисбаланс в связи с избытком негативных излучений, интоксикационную перегрузку свободными радикалами — нейрогормональная и иммунная системы организма. Восстановление их состояния обеспечивает лечебный эффект, а с учетом местных регенеративных процессов в зоне освещения, он становится наибольшим. Возможности восполнения дефицита солнечной энергии ограничены, полноценным ее заменителем является ПАЙЛЕР-свет, создаваемый апаратом БІОПТРОН.

Особенности современного подхода при светотерапии заключаются в комбинированном применении местного и системного (через точки акупунктуры) электро-магнитного воздействия ПАЙЛЕР-светом. К настоящему времени свето- и колортерапія получили официальное признание определены основные механизмы действия ПАЙЛЕР-света, показания и лечебные режимы его применения. Дальнейший поиск направлен на расширение применения ПАЙЛЕР-светотерапевтических технологий, в частности, по созданию новых лечебных программ и разработке протибольовых методик колортерапії.

Ключевые слова: БІОПТРОН, ПАЙЛЕР-свет, электромагнитные волны, электромагнитные технологии, электромагнитный дисбаланс, светотерапія, колортерапія, поляризованный свет, точки акупунктуры, энергетические меридианы, боль, иммунитет, висцеральные системы.

Introduction to electromagnetic ecology

Millions of years of life on Earth, the subsequent development of mammals and humans occurred in conditions of relatively constant exposure to electromagnetic fields (electromagnetic waves) that had natural fluctuations depending on the space and solar activity, the Earth and the Moon rotation. Accordingly, for such an important environmental factor there could not be developed physiological mechanisms of adaptation. It is also physiologically reasonable, the existence of mechanisms that utilize electromagnetic energy to ensure the needs of the current metabolic processes. In other words, electromagnetic background has some influence on the organism functional systems, and its fluctuations in the range greater than natural fluctuations (magnetic storms), cannot help but reflect on

their state. It follows that in the pathogenesis of many states of the organism, pre diseases, immunodeficiency and diseases, a significant role may play electromagnetic destabilization [35].

As an electric potential difference occurs in general on the Earth (the stratosphere - the surface) the same for the human body (head - feet), static electricity which is accumulated mainly on the skin determines the effect of electrical charges on the skin structure, and internal organs [2, 7, 71]. His fluctuation, for example, at changing weather conditions distort nerve impulses from the skin receptor areas, causing various deviations of autonomic functions. These phenomena are evident in individuals with hypersensitivity to electromagnetic differences (meteopaths). I should add that there are electromagnetic fields of the brain, heart and other organs, that interact with the magnetic fields of the Earth and artificial (man-made)

electromagnetic fields (table 2). There are described many evolutionarily developed adaptive mechanisms of body regulation functions, that depend on the electromagnetic environment: electromagnetic field orientation, presence of “biological watch” (coordinated with diurnal variation of the geomagnetic field, or time-shifted depending from latitude to latitude), “group navigation system of birds” and et al. [69]. One consider that the biorhythms of functional systems determine the quality of the reproductive function, rate of aging, and development of life-threatening disease (malignant tumors, diabetes) [11].

Empirically, perhaps, without fully realizing, the electromagnetic nature of disease, the ancient Chinese, Tibetan and Indian healers have developed technology options of acupuncture based on mechanical stimulation of structures related to the regulation of the body functions [42, 50, 57, 59, 60, 66, 68, 74, 79]. If you do not take into account the religious and mystical layers, this technology has a quite slender structure from the position of electromagnetic supply of the fundamental biophysical processes proper functioning. This process has a history of evolution lasting millions of years, as identical acupuncture points are revealed in humans and different mammals.

An important proof of the existence of the reaction zone, referred to as acupuncture points, were the results of experimental studies of analgesia. During formalin model on animals we obtained confirmation of the role of poly- and monochromatic polarized light application at E-36 acupuncture point [55]. We also revealed participation of opioidergic analgesic system, indicating on association of acupuncture points and structures located in the central nervous system [53] (Fig. 1).

So far, the hypothesis is formulated [50] that the acupuncture points can be considered as electromagnetic waves receptors, perceiving them for further transport to various organs and tissues through the meridians that are the best conductors of electromagnetic waves in comparison with the surrounding tissues. Subsequent studies confirmed the possibility of non-contact conduct of the electromagnetic waves of microwave and visible ranges of the acupuncture points to the different levels of the central nervous system [13, 24, 48, 53, 65, 67, 74] and it is found that at pain syndrome effect reaches the level of endogenous opioid systems in the brain [48]. This, parallel to anatomical structures, electromagnetic or meridian “Skeleton” is probably a quite workable form, because in the effectiveness of acupuncture no one is in doubt now. There only remains the ancient prejudice of the doctors standing on the positions of the European classical medicine, about the absence of a material substrate for the eastern technologies.

Electromagnetically sensitive acupuncture points have a number of distinguishing features, in comparison with the surrounding tissues, and can perceive electromagnetic waves of different frequencies (light

from different sources, microwave, that of very high frequency, man-made radiation, although a natural stimulant is a natural solar spectrum), causing subsequent resonant responses from atomic and molecular structures, which have functional connection with these points [50, 73]. Moreover, depending on the natural variability of the Sun and probably lunar phases affecting terrestrial magnetism, the acupuncture points may change their sensitivity, becoming “open” and “closed”.

Recently, there are obtained data on the collagen semiconducting properties, which in combination with water molecules joint into cluster structures defines liquid crystalline properties of the connective tissue. This approach, based on the above concept, explains the discrepancy between anatomical and functional efficiency, uncertainty of the concept “meridians” or “channels” in terms of oriental medicine [36]. The main grounds of the authors of this approach can be formulated as follows:

- The system of acupuncture points, meridians and constant electromagnetic field of the body belong to a holistic system of liquid-crystal fibers of collagen, which is the basis for connective tissue.
- Meridians - are oriented collagen fibers, surrounded by layers of bound water, provide permanent proton conductive pathways for rapid interconnection of all structures of the body, providing its functioning as an integrated system.

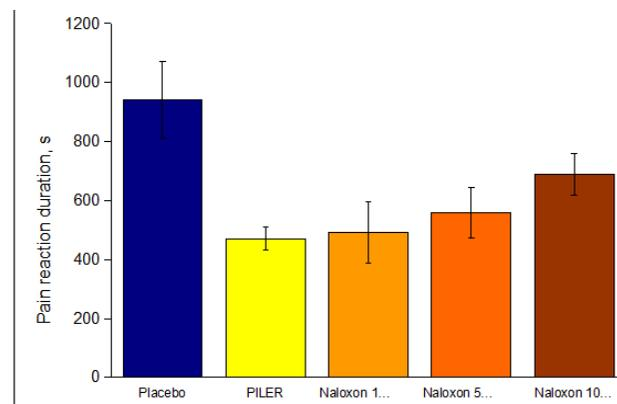

Fig. 1. The effect of naloxone blockade of opiate receptors on tonic pain:

Duration of the pain response (pain focus licking) observed for 60 min after influence on E-36 acupuncture point in the animals of the control group (placebo) and in the four experimental groups receiving only Pilar-light and in combination with doses of naloxone 1, 5 and 10 mg/kg. The figure illustrates the existence of the objective biological reaction in response to the contactless light application on acupuncture point, the existence of the connection between a remote area (point E-36 is located on the upper third of the leg) and subcortical analgesic centers, as well as the opportunity to receive clinical outcome (analgesia). Blockade of the receptors of the brain opioidergic system is illustrated by analgesia reduction at increased dose of naloxone.

- The liquid crystal “network” is involved
 - in quick response to electromagnetic waves;
 - the ability to respond to the trace substances (homeopathy);
 - the formation of hyper-reactivity to allergens;
 - emergency responses to damage.
- The liquid crystal “network” provides a link between somatic and neural structures.

To provide the mentioned processes, peculiarities of collagen structure are important, which consists of chains of molecules of tropocollagen, length 280 nm, which are oriented longitudinally parallel. These molecules do not mutually adjoin, there is a gap between them and the adjacent molecules overlap slightly. The length of the molecules is 4.4 times larger than its diameter. Tropocollagen triple helix is stabilized by hydrogen bonds between individual chains [63].

It is exactly this structure, which is the most convenient for uneven transmission of electromagnetic signals, i.e., for facilitated in the longitudinal direction. The network of collagen and elastin fibers, available in the connective tissue can probably carry both longitudinal transport of signals, for example, along the limbs and body, and irradiation of their part into the tissue depth. Location of the connective tissue around the nerve structures improves the signals broadcast into nerve fibers, which may facilitate the involvement of the nervous system in the generalized network reactions.

On the other hand, it is assumed that on the ground surface there exist magnetic anomalies (geopathogenic) zones with different physical characteristics in comparison to “standard” [6, 7, 66]. Figuratively speaking, one can call them “acupuncture” points of the earth, because they (similar to acupuncture points) are areas with altered geophysical parameters (the geomagnetic field, the electrical conductivity of the soil, the electric potential of the atmosphere, the level of radioactivity, etc.). The role of this factor has not been studied completely, although it is considered [9, 56], that it might become one of the additional conditions of the human state electromagnetic modification (generating of stress reactions responses).

The influence of Earth’s magnetic field fluctuations on heart rate can be illustrated by the results, we obtained during the transatlantic voyage “Ukraine-Antarctica” [37-38]. As singled out, the magnetic field fluctuations determine similar changes in heart rate, the dynamics of which in its turn characterizes the balance of the autonomic nervous regulation of the cardiovascular system state.

In this article, we are not going to consider in detail the extensive factual material about the influence of non-polarized electromagnetic microwave range of the physiological mechanisms of subsequent reactions at the molecular, cellular, organ and system levels. Works by ND Devyatkov, MB Galant [8] YuPLimansky (1990) [50], Y. Khurgin, IV Rodshtat, DS Chyarnavsky,

AS Efimov and SP Sitko (1993), SI Gerashchenko [14] IZ Samosyuk et al. (1999) [73] found out that even inadequate for organism electromagnetic waves transmit to the body information about the rhythms of electromagnetic field. This refers to the millimeter range (frequency, intensity, etc.), with which people coexist only a few dozen years. Its normalization is a precondition for the subsequent recovery of the function and structure of individual cells and the organism as a whole. The transmitter of the electromagnetic field parameters to molecules and cells are most likely water molecules and polypeptides (cytomedines) as the main factors of intercellular interactions.

Enough data has been accumulated on the effect of laser radiation at different wavelengths [39, 40, 61, 70], which is characterized by a narrower therapeutic strip, bordering with destructive effects (depending on the time of exposure, power, absorption). Nevertheless, the low-energy laser light having a luxf density of 0.1-1 W/cm² causes photochemical reactions: bio stimulation at the expense of photo induction (influence on cell membranes, activation of cellular metabolism, DNA synthesis, RNA, singlet oxygen formation, etc.) [4, 12, 15, 26]. Bio resonant effect [14, 61, 78], which is the leading in complex reactions in response to exogenous electromagnetic vibration, is achieved by empiric selection of shape and frequency of electromagnetic oscillations. The authors believe that the physiological homeostasis is achieved in the result of physiological frequency spectrum increase and maintenance of the relative timing of the various wave processes. Modern views on the physiological mechanisms of electromagnetic waves action you may found in [51, 54].

Influence of physical factors, having an electromagnetic component (extreme temperatures, magnetic and electromagnetic fields, microwave, light), on biological structures are largely focused on the cell nucleus [76]. According to AS Derdi [75] and VGShahbazov [76] molecular complexes that make up the system of the cell nucleus, function in a living cell at “biological” temperature as a kind micro oscillators. They convert the energy of the thermal vibrations of the water dipoles into electric charge of the nucleus and electromagnetic radiation in a wide frequency range within the cell and beyond. This energy generator provides many cellular functions, including cytoplasmic transport of substances, their exchange and inheritance implementation. The maximum development, from our point of view, this mechanism reached in deep phosphorescent fish, stingrays, eels, etc. Bioluminescence can be regarded as evolutionary hypertrophic generating property (biosynthesis) and transport of electromagnetic waves to compensate the lack, which occurs in underwater environmental medium.

There are three types of electromagnetic relationships (electromagnetic control) in the body — nervous regulation (the relationship of the central control system with the peripheral executive receptor elements),

autonomous connections between elements (cells and macromolecules) and signals, given by the control system to all the elements at the same time [68]. We assume the presence of signaling schemes of the central nervous system of the type “to all-over”: in the peripheral ganglia, the endocrine glands are “receivers” that are configured on the “emergency” rate, and provide signals retranslation to the actuators at the corresponding frequencies.

Regulation of electromagnetic endoecology

Therefore, by now, there are accumulated enough data for credible approval of the existing dependence of highly organized living beings (as unions of atoms and molecules), including humans, on electromagnetic background of Earth. Electromagnetic waves, changing the fullness of electromagnetic energy of the body frame (Fig. 2), evoke the appropriate resonances and fluctuations of the electrical potential in its molecular structures, participate in functions` control and ensure the electromagnetic homeostasis maintenance (equilibrium). Excess of reactions on waves` physical characteristics (intensity, shape, frequency, length, etc.) above physiologically required level lead to incoordination of nervous, immune and hormonal regulation.

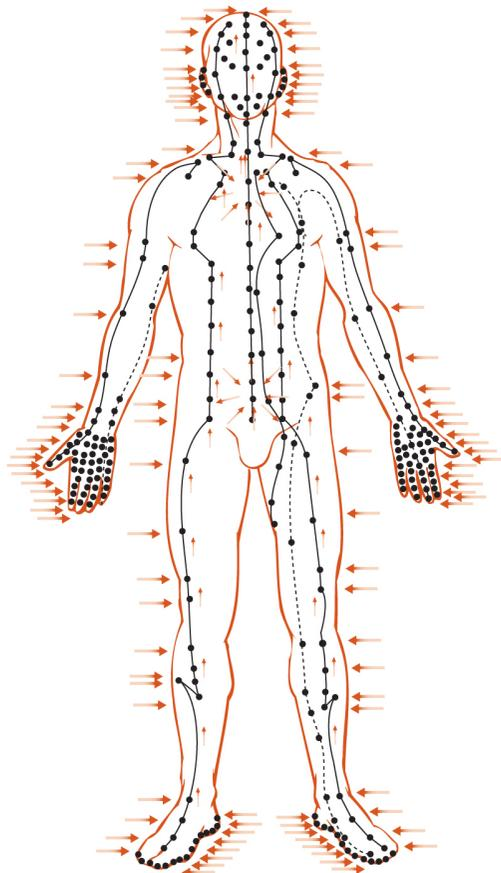

Fig. 2. Electromagnetic skeleton of the body, defined by a lightweight electromagnetic conductivity:
Ears, hands, feet are zones of high concentration of electromagnetic receptors (acupuncture points)

In fact, it is possible, with certain assumptions, to imagine the existence of a separate functional system that regulate electromagnetic balance of the body (FSREB) [27-31], containing all the ingredients of a classic functional system, according to PK Anokhin [1].

The hypothesis of the possible existence of “ecoreceptiv sensitivity” suggested by YuPLimansky, meaning its ability to monitor changes of the environmental factors (electric, magnetic fields, etc.) which do not carry information that requires immediate sensory signal [50]. Functional systems of the body are formed up of dynamically mobilized structures in the scale of the whole organism, and on their activities and the result does not reflect the exceptional impact some type of the involved anatomical structures. Moreover, the components of particular anatomical accessory are mobilized and involved in their assistance to obtain programmed result. According to the interaction principle, they are combined to achieve any adaptive result, for example, stabilization of blood pressure in the circulatory system, nervous and endocrine systems. Therefore, at systematic approach, we focus not on some anatomical feature of one component involved, but on the principles of many components organization from many anatomical systems with indispensable result of this extensive system activity [1]. The structure of the functional system of electromagnetic regulation based on the above factual material of light therapy, the example shown in Fig. 3. From our point of view, workability of such a system will depend on the quality of the external electromagnetic flux (biologically adequate wavelength range, polarization, presence of evolutionarily developed mechanisms for utilization).

As shown in Fig. 3, starting stimulus in the form of polarized electromagnetic waves within the optical range of constant magnetic field, radiation in the infrared or millimeter wave bands, as well as invasive mechanical irritation (needle stick) cause activation of poly modal (electromagnetic sensitive) receptors, i.e., acupuncture points. Transmission of electromagnetic signal is carried out through the best ways of their conductivity (meridians and connective tissue stroma). In addition, there are processes of molecular photoreception described separately [29, 52, 54]. Stimulated by electromagnetic signals, neural structures and electro dependent processes stimulate “decision taking” and determine the result of the acceptor action (visceral organ). As recipients can be considered organs, that experience electromagnetic imbalance due to the excess of biologically inadequate radiation, suffering from congestion of free radicals (lipid peroxidation), primarily, neural hormonal and immune regulatory system. Their functional state, after electromagnetic exposure, determines the (positive or negative) feedback, that is changes in electromagnetic conductivity of acupuncture points. Such self-regulation (harmonization of the existing energy background with the demanded) extend on the amount of energy absorption, regulated

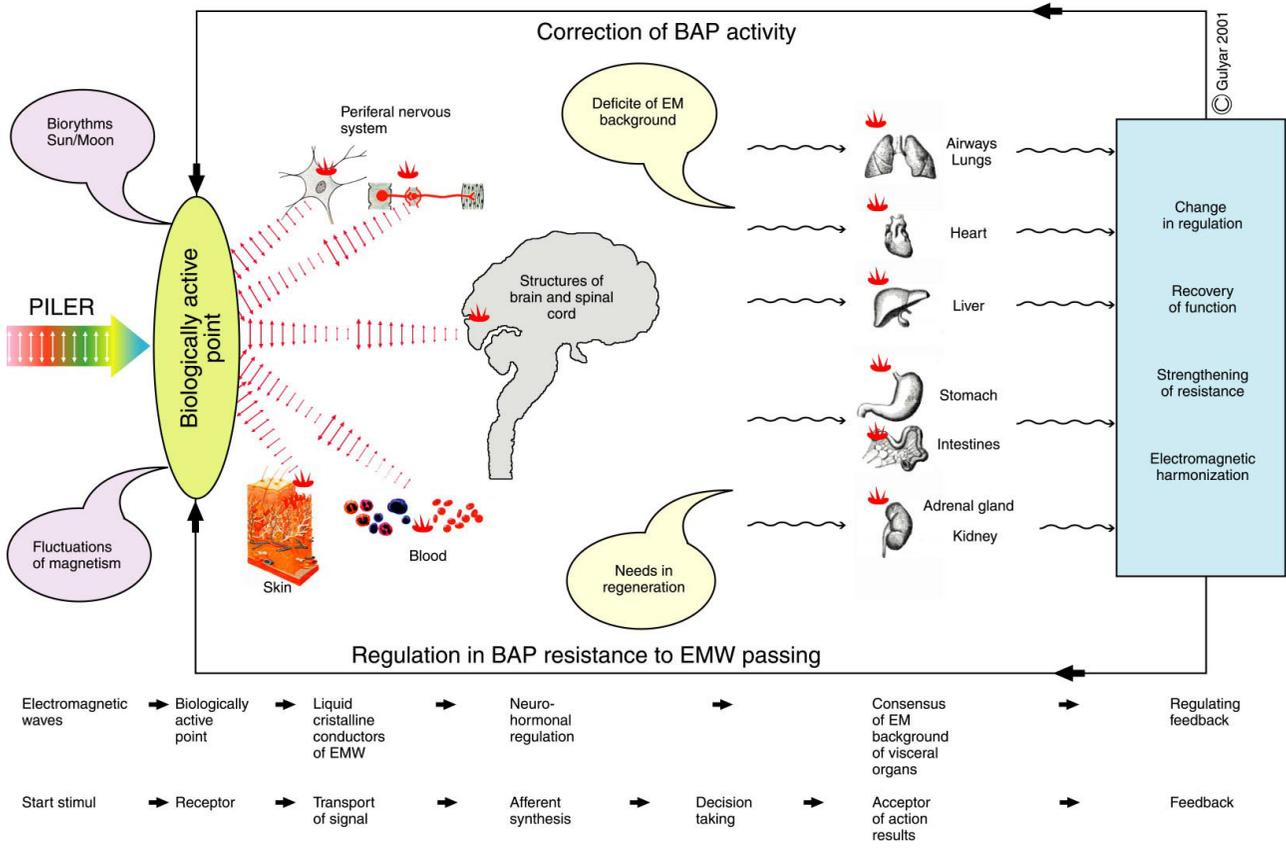

Fig. 3. General cheme of functional system of electromagnetic balance regulation

by the structures that provide electromagnetic reception. This process also depends on geomagnetic, solar and lunar activity.

It is important to mention the significance of polarized electromagnetic waves, as their polarization is the main factor causing a stable biological effect.

It should be noted that the above given scheme should be regarded as a working hypothesis, as some of its units do not yet have sound anatomical and physiological characteristics. However, in recently completed (2002) anatomical studies [49], there was performed the identification of acupuncture points on the upper limb by sonication showed their 80% coincidence with interstitial connective tissue formations (inter muscular, extending along the surface and into depth). The authors concluded that the meridians can be treated as a structure consisting of connective tissue that connect the superficial and deep formation, participating in the transfer of biophysical changes occurring under the action of the needle. There are also detailed anatomical data showing the connection of the nerve structures and acupuncture points. There are found anatomical correlates (mostly nerve trunks) of 24 primaries, 28 secondary, 27 tertiary and 31 non-specific acupuncture points. We carried out identification of 110 points in two hundred subjects [10]. This is meningful for understanding the integrative role of interstitial tissue in providing physiological effects distantly arising at acupuncture. Research of biologically active zones

relations to the surface of the human body allowed to allocate zones with “wave representation” of individual organs [45-46].

On the other hand, by biophysical modeling method [78] we established physical grounds of the existence of coherent electromagnetic field of the body (“electromagnetic framework”) in the millimeter range. There are four groups of facts, which convince the author. First of all, a pronounced presence of the electric fields intensity in cell membranes (about 10^{-5} V/cm), which is created due to through membrane ion transport. Second, frequency of the cell membranes oscillation, determined by their mechanical properties, lies within the range of 10^{10} - 10^{11} Hz. Third, the presence of skin, separating regions with different refractive indices, separates the inner area with a large refractive index, which supports more intensive radiation density at the expense of internal reflection. The fourth factor, which conditions a possibility of a coherent field, is the identity of the genome of all somatic cells of a particular organism. They can be regarded as active centers providing genome transformation into a spectrum of electromagnetic radiation. From the standpoint of the calculation of limited cycles, we showed that the meridians are (functionally) coherent running electromagnetic wave. Wave conductor properties of meridians define their internal transport in accordance with the laws of nonlinear optics for a closed resonator filled with nonlinearly absorbing medium with active

centers. Minimum of losses is determined by the fact that the angles of waves that falls on the inner surface of the skin should be less than the angle of the total internal reflection for the environment. A direct experimental proof of the electromagnetic nature of the meridians is registration by the authors of a non-equilibrium component of electromagnetic radiation of the organism in mm-range. The complex of equipment with its inner noise level for the frequency range within 53-78 GHz in the region $5 \cdot 10^{-23}$ W/Hz·cm² allowed to register radiation areas of the human body and its dynamics in the mm range. The value of the non-equilibrium component (radiation from the biologically active zones) varied in the range of 10^{-23} - 10^{-21} W/Hz·cm²

In addition, the proven clinical efficacy of PIL-ER-light also gives grounds to confirm the hypothesis mentioned above, and it is important to determine the future direction of its deep studies of individual units. For example, the “narrow” places, which will require urgent investigation, in our opinion, are the features of electromagnetic signals transport into connective tissue and the process of transmission them into nerve structure. It is important to pay attention to photo dependent processes at the level of cellular membranes and organelles, which should have a particular response to electromagnetic waves of optical range. The influence of electromagnetic and contribution factor may be the basis for clarifying biophysical mechanisms of many electro dependent processes in cells and their systems.

The main indicator of the FSREB activity, which can be determined indirectly, is the quality of the internal organs functioning and visceral systems in general. It depends on the nature of the source of the organ electromagnetic background or features of external action, which are the resulting of wavelengths, their power and exposure. From the available empirical observations, we can say that there is a natural self-regulation mechanism of the circulating volume of electromagnetic energy. For example, from clinical practice it follows that at different times of the day there is a different activity of the acupuncture points as the receptors, which receive electromagnetic waves. This is attributed to sun exposure and biorhythms (depending on the phase state of the Sun and the Moon). At daylight, when we observe a high level of electromagnetic energy falling on the surface of the body, many acupuncture points are “closed” (become less susceptible to excess energy), in the dark - “open.” Moreover, at diseases followed by increased peroxide oxidation (which usually happens) in the respective systems of visceral tissue there increases metabolism and power consumption, there appears an energy deficit. At the same acupuncture points, “responsible” for the particular organ or segmental area, “open”, and become strongly susceptible to electromagnetic factors up to respond to mechanical stimulation. At this time, these points become sensitive and you can easily determinethem on your body.

From the standpoint of light puncture, it becomes clear and understandable the existence of areas with a high concentration of biologically active points on the body (face, ears, hands, feet) as the sites that in the process of evolution has always been open to solar (light) electromagnetic waves (unlike protected by fur or clothing). Alongside, it is observed a general biological principle of multiple redundancy (backup) in case of traumatic injury of one of their sites.

The above hypothesis of the FSREB explains the non-correspondence between the anatomical and functional efficiency of “meridians” or “channels” concept in terms of oriental medicine [62]. In accordance with this approach, the system of acupuncture points, “meridians”, as well as permanent and variable electromagnetic fields of the human body interact with the holistic system of liquid crystal fibers of collagen, which is the basis of connective tissue.

On the effectiveness of the considered working FSREB hypothesis may also indicate the effectiveness of BIOPTRON-color therapy method, which is based on the influence of electromagnetic waves of different lengths on biologically active zones (points) [3].

We should say that the existence of a system that regulates relations between the body and the external electromagnetic field with more or less empiricity is always under consideration. In particular, R Becker [2] described a “slow electromagnetic system of regulation in vertebrates”, which is associated with a peculiar distribution of the surface potential (Fig. 4). The author presents evidence that this system controls the speed of electrical impulses extension in nerves, transmits to CNS information associated with pain and mental functions. He suggests that this system controls the general behavior of animals and that through it is carried out the influence of the magnetic and electric fields of Earth on animals and humans [69].

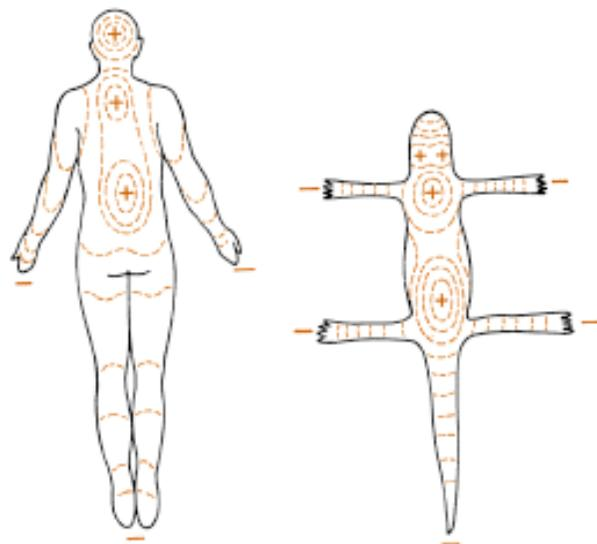

Fig. 4. Distribution of surface electric potential on the human body and lizards [65]

An interesting approach of VGMakats et al. [58] is based on measurements of the electrical conductivity of biologically active zones. There are revealed the interdependent self-functioning energy cycles, especially the regulation of vegetative homeostasis and the interaction between the individual functional systems of the body. This allowed the authors to put forward the idea of the existence of “functional-energy system of biological objects (Makats effects).”

Violations of the harmony of the electromagnetic interactions of the external and internal environment determine the occurrence of various types of pathology. The resulting deformation of this body’s electromagnetic field can be recorded using Kirlian effect [47]. Modern methods of the human body electromagnetic radiation measurement in mm range is already allow to detect the presence of a non-equilibrium component [78], i.e., “Aura” that characterizes the individual peculiarities of the body functional state (Fig. 5).



Fig. 5. Plant bio field reaction in response to the impact of human bio-field [77]:

- A - human generation thoughts of love and kindness to the plant;
- B - plant responses to positive "emotions";
- V - generation of human thought "I'll cut you";
- T - plant responses to negative "emotions"

Electromagnetic exoecology and its significance for the organism

Let us consider the relationship of organism with the environment from a position of “usefulness” of certain types of electromagnetic waves. Urbanization, a companion of life in the modern world gives rise to many electromagnetic wavelengths not found in the evolution. When applied to the “usual” waves, for example, solar spectrum, we can talk about a possibility of specific adaptation (accumulation of melanin in the skin of Africans, blond color for northerners, etc.) and non-specific neuro hormonal activation of antioxidant system to block lipid peroxidation. Then for historically “new” influences, there are observed different and usually negative variety of responses. Generally recognized term “electromagnetic pollution” (electromagnetic smog) indicates patterns of adverse effects of the electromagnetic field increasing with exposure and frequency characteristics. The greatest amount of information is available about the biological effects of microwaves, which is expressed in the disorder of the central nervous system, followed by dysfunction of visceral systems up to the heating (destructive) effect.

The consequences of an adverse effect on the organism of environmental factors can largely be reduced to common resulting pathophysiological mechanisms. It can be described as an overload of the antioxidant system, forced to neutralize the excess of free radicals generated by both external and internal environments. The final process is the increase in lipid peroxidation (oxidative stress), during which there occurs destruction of cell membrane lipids, enzymes, disintegration of regulatory influences, mutagenicity increased and other negative phenomena, which ultimately determine sickness rate and life expectancy (Table 1).

Table 1

Two leading complexes of environmental factors that determine the state of health

ENVIRONMENTAL (PEROXIDATION) STRESS	ELECTROMAGNETIC MISBALANCE
FREE RADICAL INTOXICATION	INSUFFICIENCY OF BIOLOGICALLY DEMANDED RANGE EM WAVES
ENHANCING PEROXIDATION	EXCESS DISRUPT RANGE EM WAVES

A second, less studied, but not less important aspect of determining the state of health is the maintenance of normal background levels of electromagnetic stimulation of biochemical and biophysical processes. The example of the difference in the quality of plants growth, grown in the basement and in the sunlight, once again convinced of the need to provide every earth living being with insolation, the intensity of which cannot be below a certain critical value. However, the electromagnetic imbalance, everywhere overtaking each of the members of a modern society, give evidence of insufficient obtain, by many of them, of electromagnetic waves of necessary biologically range (insolation), and an excess of the action of destructive electromagnetic influences. In fact, we speak of substitution for the body of one wavelength for another, which “taking” a somebody else place (ecological niche) “parasitize” (causing physiologically inappropriate resonant and thermal effects) and bring destabilization where cellular structures are waiting for natural (due) wave.

These technogenic electromagnetic fields have a simpler frequency organization and pulse structure; however, they have several orders of magnitude greater intensity and uneven localization in space [62]. As damaging electromagnetic waves are in uncontrollable excess, the list of adverse effects is hard to predict, but in any case, these changes could become irreversible.

The significance of the new urbanized electromagnetic environment at home is very important. According to measurements carried out at the Institute of Terrestrial Magnetism and Radio Wave Extension [71], “a characteristic tension on the surface of the human body varies from 20 to 200 V/m, reaching on top of 1000 V/m. Wearing natural clothing gives almost no

effect on these statements. Clothing made of synthetic materials when it is removed, or natural movements creates strength values up to 14,000 V/m, contributing to the development of cardiac arrhythmias. The same refers to shoes made of synthetic materials — the sole while in contact with asphalt, at each step, generates a voltage of 10–20 kV. With small dimensions of standard flats and excess of furniture in them of non-natural materials, surrounded by wiring each dwelling turns into a ball of electromagnetic fields, each protrusion of furniture — in the storage of kilovolt static charges. Friction of tires on the asphalt turns a moving car in a good capacitor”.

From this non-equilibrium state there can be only two alternatives: the first — leaving the radiation zone, reducing the length of stay or screening (with attenuation coefficient over 2 growing shortage of natural electromagnetic background, followed by a deterioration of health [71]); and second — restoration of the volume of the incoming electromagnetic waves solar spectrum. Natural illustration of the above can be considered as the situation with the winter-spring morbidity and efficiency improvement of the summer. Indicative data, obtained during the survey of the population of different regions of Ukraine [18, 19]. Let us consider in more detail the main groups of mentioned electromagnetic influences (Table 2).

As you can see, natural capabilities that compensate electromagnetic waves of solar spectrum are limited and the only adequate alternative is polychromatic polarized (PILER) light. Accordingly, the device BIOPTRON as its generator represents an additional opportunity to align the electromagnetic balance.

The range of sun doses influence fluctuations in terrestrial conditions is very broad, and they vary depending on the different circumstances (Table 3). It is significant that an overdose of sun exposure mostly accompanied by an increased dose of its ultraviolet and infrared parts, and its lack reveals in a decrease of the visible portion of the solar spectrum. It should also be noted that even the small part of the sunlight that reaches the Earth's surface in polarized form, under the influence of industrial dust or smog, is depolarized and loses biological effectiveness.

Main mechanisms and the concept of PILER-light therapy

From these data it follows that general indications for correction of the electromagnetic imbalance can be called a disorder associated with electromagnetic lack, overload by “parasitic” electromagnetic waves and free radicals. BIOPTRON-PILER-light therapy method is the most appropriate to provide the most physiological way of electromagnetic harmony recovery at all levels of the organism — from molecular to systemic.

While the direct impact on the biological substrate of electromagnetic waves of the visible spectrum there

occurs a direct energy replenishment of the electron orbits components and transition of electrons to higher levels, which increases the chemical activity of atoms.

Redistribution intermolecular energy leads to modification of the molecule, which defines a more pronounced stabilization of its structure. Restoration of the structure portions of cell membranes by electromagnetic reconfiguration of molecules increases the membrane potential and its ability to resist the action of free radicals. Especially effective action, PILER-light manifested in case of electromagnetic imbalance that defines the subsequent leveling therapeutic effect. Here reveals biophysical aspect of the PILER-light antioxidant effect.

This process prevents the progress of other, less favorable changes occurring under the influence of electromagnetic wave of other lengths (ultraviolet, infrared, microwave, etc.), manifested in the strengthening of intermolecular oscillatory processes, heating and breaking of intermolecular bonds.

Manifestations of the general mechanism of PILER-light action will not be the same depending on the regional properties of the perceiving surface area of the skin. The process described above takes place in all cases of direct (local) impact. However, if in a zone of light application gets a biologically active (acupuncture) point, there turns on the mechanism of “lightweight” entering of biologically necessary electromagnetic energy range and its subsequent transport to customers located in the electromagnetic “frame.” Thus, there appears a possibility of systemic influence on organs distant from the application site. This principle is the basis for BIOPTRON color therapy technology as a painkiller and visceral system correcter.

PILER-light due to its polarization has better penetration ability compared to non-polarized electromagnetic waves. This opens up another useful chain connected with direct influence on the cells and plasma of blood passing through the capillaries of the skin.

Restoring of their function ensures, on the one hand, strengthening of the structure of erythrocyte membranes and extending the active life period of red blood cells in the bloodstream, and on the other hand — activation of leukocytes and lymphocytes function — immune proteins production, increase of phagocytosis, etc. [65, 72]. It is typical, that at almost any light application capillary network is automatically covered within the illuminated area and, accordingly, the immune normalizing mechanism starts to work, which is extremely important for practical medicine.

Currently known mechanisms of polarized light action are actually aimed at slowing down the natural process (apoptosis) or induced (necrosis), destruction of cellular functions, i.e. breaking the process of cell death.

The PILER-light therapy concept, in modern sense, consists in combined application of local and systemic effects of polarized electromagnetic waves of

Table 2

Types of electromagnetic influences

DESTROYING	DESTABILIZING	REGENERATIVE
<ul style="list-style-type: none"> ⊕ Cosmic rays ⊕ Abundant solar Activity ⊕ Gamma rays ⊕ X-rays ⊕ UV rays ⊕ IR rays ⊕ Microwaves (more than 1 mW/cm²) ⊕ LAZER-light (high energy) ⊕ Ultrasound 	<ul style="list-style-type: none"> ⊖ Transportation <ul style="list-style-type: none"> • Electric locomotive, Metro • Trams, trolleybuses • Power Lines • Flights ⊖ Domestic <ul style="list-style-type: none"> • Microwaves • TV • Radio sets • Cell Phones • Conditioners • Aerowaterionizers, ozonizers • Plastics ⊖ In office <ul style="list-style-type: none"> • Displays PC • Electric engines • Transformers • Ultrasound equipment • Radars • High-frequency generators • Radio TV stations ⊖ Noise producers <ul style="list-style-type: none"> • Traffic noise • Concert noise • Industrial noise ⊖ Molecular-nuclear <ul style="list-style-type: none"> • Torsion fields • Gravitation fields ⊖ Magnetic storm <ul style="list-style-type: none"> • Solar • Earthly 	<ul style="list-style-type: none"> ⊕ PILER-light (polychromatic, 95 % of polarization, low-energy) ⊕ Sunlight (polychromatic, up to 3 % of polarization) ⊕ LASER-light (monochromatic, polarized, low-energy) ⊕ Mikrowaves (Nonpolarized, less than 1 mW/cm²) ⊕ LED-light (monochromatic, non polarized, low-energy)

Table 3

Reasons for the solar electromagnetic disharmony

NATURAL	ARTIFICIAL
OVEREXPOSURE	
<ul style="list-style-type: none"> ◆ Mountain conditions ◆ Recession of ozone layer ◆ Solar atmospheric magnetic storms ◆ Polar (summer) day 	<ul style="list-style-type: none"> ◆ Many hours of work in the sun ◆ Sun overdose ◆ Overexposure to the sun/snow in the mountains ◆ Solarium overdose exposure ◆ Electric welding
DEFICIENCY EXPOSURE	
<ul style="list-style-type: none"> ❖ Atmosphere pollution ❖ Long dense cloudiness ❖ Magnet atmosphere anomalies ❖ Polar (winter) night 	<ul style="list-style-type: none"> ❖ Stay in low light premises ❖ Stay in screened rooms, transport, marine and submarine vessels ❖ Work in mines, workshops, basements, hyperbaric chambers ❖ Distorted sunlight structure by glass, light filters

biologically necessary (solar) range, using specialized sensory receptor or sensory entrance gates, liquid-crystal conductors and all the connective framework for electromagnetic energy transport to regulatory system or areas, experiencing its deficit or imbalance.

In case of PILER-light therapy prescription, it is important to know the mechanisms of action of polarized light and clearly determine the feasibility of its application. It is helpful to understand the PILER-light therapy-leading role in a complex antioxidant Zepter technology (simultaneous use). Enhancing of the effect in this case is provided by unidirectional (peroxide oxidation-reduction), correction of various components of antioxidant balance [20]. The point of application and the level of biochemical or electromagnetic antioxidant protection, in each case, are not the same — from the cell membrane to the systemic organ that creates a multi-level and wider coverage for such electromagnetic disharmonies protection.

Achievements and prospects of PILER-light therapy technologies

Start of the 3rd millennium for light therapy, as for physical therapy technique in a broad sense, is characterized by “warming” of “classical” medicine attitude and successful search of cooperation with experts applying “non-traditional” approaches. This is due to accumulation of objective information about the mechanisms of the physical factors action for specific medical purposes, the expansion of the devices` features and transition to a new level of computer processing and evaluation of facts. New methodological possibilities defined reassessment of the existing provisions and allowed to provide greater depth of the facts analysis. The gulf reduced between “fundamental” and “applied” researches, which in fact, under the new conditions of the Ukrainian science existence, have grown finally together in a comprehensive system to obtain reliable scientific facts, introduce them into clinical disciplines

and receive timely feedback on the medico-social “order” for new research. In this sense, light therapy occurred in a pole position. On the one hand, in due time, there appeared a new generation of light therapy equipment, sophisticated Bioptron device, on the other — thanks to open to independent research policy of Zepter Company, it has become real in Ukraine to do theoretical and clinical research, with the ultimate aim to create better opportunities for health correction and improve quality of life. Contribution to the fast track of light therapy technology development has made public understanding of the rapidly of negative “parasitic” electromagnetic background growing, which increased its demand [12, 17, 25, 26, 41, 43, 64, 65, 74, 80].

The greater the accumulated knowledge of physical therapy techniques, the more visible they are incomplete. Clinical needs and expectations of users require for Advanced Studies of increasing complexity and depth of analysis. Clarification of the PILER-light mechanisms of action has not changed its clinical efficiency, but the list of diseases and premorbid disorders got a trend to decrease, which reflects improvement in the quality of care. A number of myths, caused by primary enthusiasm and unexplained effects, gradually disappear, it is replaced by a sober list of indications that distinguishes a professional approach. However, the technology remains to be designed for a wide user, preferably having BIOPTRON at his own home. The task of the researcher continues to remain bidirectional — deeply investigate undisclosed facets of the technology and to provide specific modes for practical application. Status of knowledge about the basic issues of solved and unsolved light therapy technologies, which appeared to date, are presented in Table 4.

Thus, at present, questions of legal and medical legalization of light and color therapy can be considered as resolved. There are defined the basic mechanisms of PILER-light action and a set of indications for applications. It is developed the first generation of therapeutic regimes and color therapeutic programs.

Table 4

BIOPTRON: solved and unsolved questions

SETTLED SOLVED	FOR DECISION
Full medical and legal authorization of BIOPTRON devices	Updating of the list of diseases for which light therapy is effective
The main mechanisms of PILER-light action are defined	Detailization of physiological and pathophysiological mechanisms of PILER-light action
The basic therapeutic areas are described	Search for the new aspects of the therapeutic, restorative and preventive application of PILER-light
Established the basic indications for treatment and correction	Extension of family BIOPTRON devices application
It created the first generation color therapy treatment and rehabilitation programs	Implementation of color therapy programs and creation of their new modifications
Initial introduction of the population of the possibility of Bioptron light therapy	Full coverage (each family) by light and color therapy technologies

In recent years, attention has been paid to a new nano filter containing fullerene (the fourth form of carbon state, molecular, C_{60}) [81]. It is able at the nano level to change the properties of the light passing through it. Accordingly, such light can acquire additional properties [82].

They arise due to the fact that the carbon atoms entering into the C_{60} molecule can influence the trajectory of the transmitted light quanta by its own electromagnetic oscillations, which obey the icosahedral symmetry of the shell. Rotating at speed of $1.8 \cdot 10^{10} \text{ s}^{-1}$, the spatial network of carbon atoms entering the C_{60} molecule, in accordance with the Fibonacci distribution law ($\Phi^2 + \phi^2 = 3$), additionally redistributes the light electromagnetic flux. Such a modification of the light flux was called "hyperpolarization". When light passes through a fullerene material 2 mm thick (10^6 layers of C_{60} molecules), there occur changes 10^{18} in the direction of the motion of quanta. Taking into account the rotation of the C_{60} molecule, a new, more ordered spiral configuration of their flow (Tesla toroids) is eventually created. The symmetry of the flux of quanta obtained in this way should create harmonizing possibilities for more efficient absorption of each of the passing quanta [82-84].

It was experimentally established [85, 86], that a 10-minute application to the inflammation locus or to E-36 acupuncture point of fullerene light caused in animals a significant reduction of pain. Analgesia was 43.5 and 38.5 %, respectively. All non-painful behavioral reactions increased their duration. Duration of sleep compared with the control increased twice (application of light to the locus of inflammation) and 3 times (application to acupuncture point E-36).

Comparison of these data with the results obtained for monochromatic polarized light ranges showed that they could be attributed to the most effective group of analgesic light factors. Fullerene light, along with analgesic, have a powerful sedative effect, surpassing effects in comparison with all other ranges of polarized light.

So, **the new fact is that** polarized polychromatic light of the BIOPTRON device, which has passed through a nano photonic fullerene filter, acting onto the pain or acupuncture point E-36, significantly reduces pain and has a sedative effect.

Conclusion

Presented analytical material comprises a working concept of light therapy based on modern views of the relationship between electromagnetic factors with a living organism. It is based on the use of acupuncture points for the biologically necessary electromagnetic waves to enter the system (frame) of the conductors and consideration the electromagnetic framework as a means of light range polarized electromagnetic waves transport. Their zones-recipient may be considered organs that endure electromagnetic imbalance due to the excess of biologically inadequate radiation, suffering from free radicals' congestion (peroxidation) – neuro hormonal and immune regulatory systems of the organism to a greater or lesser extent related to biologically active periphery. Subsequent stimulation or modification of functions of the recipient zones determines the achievements of useful therapeutic effect, combination of which with local reparative processes, derived from direct exposure, allows to achieve the clinical purpose. The results of targeted experimental studies and clinical experience that gradually accumulate, will refine or change some of the positions that will give an impetus to the further improvement of the light therapy technology, and perhaps will give a qualitative leap.

The light therapy success now requires coordination of professionals` having experience in the field, systemic discussions, regular publication of the experimental results and clinical studies, significant efforts to extend information among managers and users, corresponding lecture activity.

BIOPTRON-light therapy is a new and promising direction for a wide range of specialists, from representatives of theoretical medicine to clinicians and practitioners (beauticians, chiropractors, etc.). Studies in these new directions will always remain rewarding, as the expansion of knowledge of concrete members and associates defines the achievement of a new quality of health medical support, the pursuit of which is humane and honorable task of everyone.

The author will consider the goal reached in case of a significant appearance of interest to issues of electromagnetic ecology, BIOPTRON light therapy, and as a result, occupation by it a leading position in physical therapy.

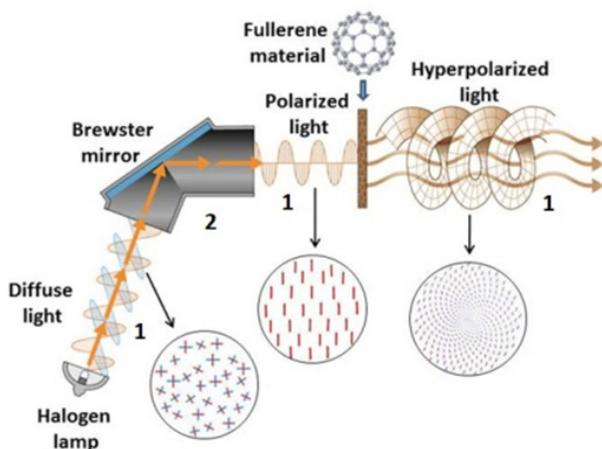

Fig. 6. Scheme of converting diffuse light into vertically linearly polarized and hyperpolarized [19, 83, 84]:

1 – scheme of oscillations of vectors of light electromagnetic waves, 2 – Brewster polarizer of the BIOPTRON device.

Differences in the vector structure of the light fluxes are shown separately (circled).

Conclusions

1. The increase of the adverse electromagnetic background may be an additional cause for non-specific disease growth. The last can be explained by the presence of electromagnetic imbalance and environment-related free radical overloads.

2. Natural options to compensate electromagnetic wave solar spectrum lack is limited, adequate alternative is PILER-light.

3. We put forward the hypothesis of the existence of the body's functional system of electromagnetic balance regulation.

4. Working light therapy concept is based on the possibility of using acupuncture points, the biologically necessary electromagnetic waves, to enter conductors and consideration of this electromagnetic framework as a means of transport. Zones-recipient are named organs experiencing an electromagnetic imbalance due to excess of biologically inadequate radiation, overload by free radicals of neuro hormonal and immune regulatory systems. Subsequent stimulation or modification of functions of zones-recipient determines the achievement of useful therapeutic effect, combination of which with local reparative processes allow to achieve clinical goals.

5. The modern approach to light therapy is in combined (local and systemic) impact of electromagnetic waves of biologically necessary (light) range.

6. Settled, for the present time, can be considered legal and medical recognition of light color therapy, the basic mechanisms of PILER-light action, a list of indications, and the first generation of therapeutic regimes and color therapy programs.

7. Intensification of light therapy implementation technology is associated with the need to create new treatment programs and to develop color therapy analgesic technologies. We are faced with search and disclosure of PILER-light therapeutic action mechanisms in respect to the visceral systems, studies in biophysics, virology, veterinary medicine, crop and emergency medicine, development of a new generation of light therapy equipment, as well as Zepter antioxidant technologies consolidation.

References

- Anokhin PK. Essays on the physiology of functional systems. Moscow: Medicine, 1975; 447 p. (in Russian). *Анохин П.К. Очерки по физиологии функциональных систем.* - М.: Медицина, 1975.- 447 с.
- Becker R. The direct current control system. A link between environment and organism. NY State J Med. 1962; 62:1169-80.
- Bioptron-color therapy. Gulyar SA, editor. Kiev: Zepter, 1999; 104 p. (in Russian). *Биоптрон-цветотерапия / Рук-во под ред. С.А. Гуляра – Киев: Цеттер.- 1999.- 104 с.*
- Bobrova EA. Treatment of osteoarthritis by a helium-neon laser and infrared spectrum - In: Internat. Scientific-practical conference. Med. rehabilitation, balneology and physiotherapy. -Yalta, 1999; p. 156-157 (in Russian). *Боброва Е.А. Лечение остеоартроза методом лазеротерапии гелий-неоновым и инфракрасным спектром – В кн.: Междунар. науч-практ. конф. «Мед. реабилитация, курортология и физиотерапия».- Ялта.- 1999.- С. 156-157.*
- Bogdanov GB. Nonlinear neuroelektrodinamiks and ekobalancing. Kiev: Univ USKHA, 1991; 406 с. (in Russian). *Богданов Г.Б. Нелинейная нейроэлектродинамика и экоуравновешивание.- Киев: Изд-во УСХА, 1991.- 406 с.*
- Bogdanov GB. Eco ties of bio phenomena. Kiev: Ukraine, 1991; 80 p. (in Russian). *Богданов Г.В. Экоsvязи биофеноменов.- Киев: Информ.-издат. Агентство «Украина», 1991.- 80 с.*
- Bogush DA. Electromagnetic, geo pathogenic radiation and energy. Kiev: Impuls, 1999; 40 p. (in Russian). *Богущ Д.А. Электромагнитные, геопатогенные и энергоинформационные излучения // Киев: Импульс, 1999.- 40 с.*
- Devyatkov ND., Golant MD. Millimeter waves, and their role in vital activity. Moscow: Radio and link. 1991; 61 p. (in Russian). *Девятков Н. Д., Голант М. Б. Миллиметровые волны и их роль в процессах жизнедеятельности.- М.: Радио и связь.- 1991.- 61 с.*
- Dubrov AP. Terrestrial radiation and human health. M.: AMF, 1992.- 45 p. (in Russian). *Дубров А.П. Земное излучение и здоровье человека. М.: АИФ, 1992.- 45 с.*
- Dung HC. Anatomical acupuncture. San Antonio, Texas: Antarctic Press, 1997.- 533 p.
- Dylman VM. Large biological clock (Introduction to Integral Medicine) . M.: Znanie, 1981. 208 p. (in Russian). *Дильман В.М. Большие биологические часы (Введение в интегральную медицину).- М.: Знание.- 1981.- 208 с.*
- Dyvocha VA. et al. Study of the of polarized light BIOPTRON device action on the host defenses at lethal viral infection. Antology of light therapy, Proc. Kiev: BIP NAS of Ukraine, 2009. p. 461-469 (in Russian). *Дивоча В.А., Микелашвили М.Т., Костева Т.К. Изучение действия поляризованного света аппарата БИОПТРОН на защитные силы при летальной вирусной инфекции // см. наст. сборник, с. 461-469.*
- Fedorov SM., Fedorova VV. Electro magnetic field of millimeter diapason influence on cerebral hemodynamics in sick with the initial manifestations of blood circulation lack in brain - In: Intern. Scientific-practical conf. Medical rehabilitation, balneology and physiotherapy. Yalta, 1999. p. 163-164 (ua). *Федоров С.М., Федорова В.В. Вплив електромагнітного поля міліметрового діапазону на церебральну гемодинаміку у хворих з початковими проявами недостатності кровообігу мозку – В кн.: Междунар. науч-практ. конф. «Медиц. реабилитация, курортология и физиотерапия».- Ялта, 1999.- С. 163-164.*
- Gerashchenko SI. Fundamentals of therapeutic application of electromagnetic fields of the microwave range. Kiev: Rainbow, 1997. 223 p. (in Russian). *Герашченко С.И. Основы лечебного применения электромагнитных полей микроволнового диапазона. К.: Радуга, 1997.- 223 с.*
- Grabostchyner AJ, Korepanov V., Chaifez YB. Quantum therapy in classical cosmetology. Moscow: Milta. 2000. 74 p. (in Russian). *Грабошчинер А.Я., Корепанов В.И., Хейфец Ю.Б., Шамов В.Б., Пашков Б.А. Квантовая терапия в классической косметологии: Метод. пособие для врачей.- М.: ЗАО Милта-ПКП ГИТ.- 2000.- С. 74 с.*
- Gulyar SA. Dual technology to maintain health in ecologically unfavorable conditions: PILER-light and antioxidants synergies. In: BIOPTRON theory, clinical perspec-

- tive. Proceedings of the Jubilee. conf. Kiev: Zepter. 1999. p. 6-21 (in Russian). Гуляр С.А. Двойная технология сохранения здоровья в экологически неблагоприятных условиях: синергизм ПАЙЛЕР-света и антиоксидантов // БИОПТРОН: теория, клиника, перспективы. Материалы юбилейн. конф.- Киев: Цептер.- 1999.- С. 6-21.
17. Gulyar SA. Winter 2000 - Bioptron contribution to winter recreation. Zepter-news. 1999; 8: 18-19 (in Russian). Гуляр С.А. Зима-2000 – вклад Биоптрона в зимнее оздоровление. // Цептер-новости.- 1999.- № 8. – С. 18-19.
 18. Gulyar SA. Does Ukraine need BIOPTRON: medical position. Zepter-Ukraine. 2000; 10: 18-20 (in Russian). Гуляр С.А. Нужен ли Украине БИОПТРОН: медицинская точка зрения // Цептер-новости.- 2000. № 10.- С. 18-20.
 19. Gulyar SA. Medical and physiological rationale for light therapy in Ukraine (according to the regional screening questionnaire). In: Anthology of light therapy, Proc., Kiev: BIP NAS of Ukraine, 2009. p. 112-121 (in Russian). Гуляр С.А. Медико-физиологическое обоснование необходимости светотерапии в Украине (по данным регионального анкетного скрининга) // Антология светотерапии, ИФБ НАНУ, 2009, с. 112-121.
 20. Gulyar SA. Medical and physiological strategy of the company and the role of Zepter BIOPTRON devices in its implementation. In: Anthology of light therapy, Proc., Kiev: BIP NAS of Ukraine, 2009. p. 28-43 (in Russian). Гуляр С.А. Медико-физиологическая стратегия компании Цептер и роль аппаратов БИОПТРОН в ее реализации // Антология светотерапии, ИФБ НАНУ, 2009, с. 28-43.
 21. Gulyar SA. BIOPTRON: electromagnetic environment and the organism. *Ridna priroda*. 2002; 4: 37-41 (in Russian). Гуляр С.А. БИОПТРОН: электромагнитная экология и организм // Рідна природа.- 2002.- № 4.- С. 37-41.
 22. Gulyar SA. BIOPTRON project in Ukraine. Zepter News. 2002; 16: 20-23 (in Russian). Гуляр С.А. БИОПТРОН-проект в Украине // Цептер-новости.- 2002.- № 16.- С. 20-23.
 23. Gulyar SA. Concept of the electromagnetic balance of the body and the Environment: the role of BIOPTRON light therapy. In: New technologies - the path to the future. Proc. of studies and development works. Kiev-Donetsk: South-East, 2003; 2: p.108-120 (in Russian). Гуляр С.А. Концепция электромагнитного баланса организма и окружающей среды: роль БИОПТРОН-светотерапии // В кн.: Новые технологии – путь в будущее. Сб. научных трудов и разработок, вып. 2.- Киев-Донецк: Юго-Восток, 2003.- С. 108-120.
 24. Gulyar SA., Limansky YuP, Tamarova ZA. Acupuncture analgesia by BIOPTRON-PILER-light for physiotherapy. In: Internat. scientific practical conf. Medicine, rehabilitation, balneology and physiotherapy. Yalta. 1999. p. 134-135 (in Russian). Гуляр С.А., Лиманский Ю.П., Тамарова З.А. Акупунктурная анальгезия БИОПТРОН-ПАЙЛЕР-светом для физиотерапии // Междунар. науч.-практ. конф. «Медиц. реабилитация, курортология и физиотерапия».- Ялта.- 1999.- С. 134-135.
 25. Gulyar SA, Nykula T.D., Kyrylenko E.E., Kyrylenko E.K. Influence of PILER-light on the visceral systems: cardio-renal effects. In: Anthology of light therapy, Proc. Kiev: BIP NAS of Ukraine, 2009. p. 421-429 (in Russian). Гуляр С.А., Ныкула Т.Д., Кириленко Е.Е., Кириленко Е.К. Влияние ПАЙЛЕР-света на висцеральные системы: кардио-ренальные эффекты // Антология светотерапии, ИФБ НАНУ, 2009, с. 421-429.
 26. Gulyar SA, Limansky YP, Tamarova ZA. Pain and BIOPTRON. Kiev: Zepter. 2001; 128 p. (in Russian). Гуляр С.А., Лиманский Ю.П., Тамарова З.А. Боль и БИОПТРОН. Киев: Цептер.- 2001.- 128 с.
 27. Gulyar SA, Limansky YP, Tamarova ZA. The functional system of electromagnetic regulation; unsolved questions. In: Materials of the 26th Congress of the Ukrainian physiology society. Vinnitsa, May 28-30, 2002. *Physiol. J.*, 2002; 48(2):21-22 (in Russian). Гуляр С.А., Лиманский Ю.П., Тамарова З.А. Проблема функціональної системи електромагнітної регуляції та невирішені питання її легалізації. // Матер. 26-го з'їзду Українського фізіологічного товариства, Вінниця, 28-30 травня 2002 р.- Фізіол. ж.- 2002.- 48, № 2.- С. 21-22.
 28. Gulyar SA, Limansky YP, Tamarova ZA. Using of the functional systems of electromagnetic regulation to correct disorders of visceral systems. *Physiol. J.* 2002; 48(4):117-118 (in Russian). Гуляр С.А., Лиманский Ю.П., Тамарова З.А., Колтаков І.Є., Богуш Д.А., Сірик О.А. Використання функціональної системи електромагнітної регуляції для корекції розладів вісцеральних систем // Фізіол. ж.- 2002.- 48, № 4.- С. 117-118.
 29. Gulyar SA, Limansky YP. Functional system of the organism electromagnetic balance regulation: mechanisms of primary reception of electromagnetic waves of optical range. *Physiol. J.* 2003; 49(2): 35-44 (In Ukrainian). Гуляр С.О., Лиманський Ю. П. Функціональна система регуляції електромагнітного балансу організму: механізми первинної рецепції електромагнітних хвиль оптичного діапазону // Фізіол. ж. – 2003. – 49, № 2. – С. 35-44
 30. Gulyar SA, Limansky YP. Functional system of regulation of the organism electromagnetic balance. In: Mater. 13th Intern. Conf. Microwave equipment and telecommunication technologies. Sevastopol, 8-12 September. 2003. Sevastopol: Weber, 2003; p. 101-103 (in Russian). Гуляр С.А., Лиманский Ю.П. Функціональна система регуляції електромагнітного балансу організму // Матер. 13-й Междунар. конф. «СВЧ-техника и телекоммуникационные технологии», Севастополь, 8-12 сент. 2003 г.- Севастополь: Вебер, 2003.- С. 101-103.
 31. Gulyar SA, Limansky YP, Tamarova ZA, Bogush DA. A functional system of regulation of the electromagnetic balance of the body and the evidence of its activities. In: Mater. 8th Int. Conf. Diagnostic and therapeutic technology in quantum medicine. Donetsk, 2003; p.158-164 (in Russian). Гуляр С.А., Лиманский Ю.П., Тамарова З.А., Богуш Д.А. Функціональна система регуляції електромагнітного балансу організму и доказательства ее деятельности / Матер. 8-й междунар. конф. «Диагностические и лечебные технологии в квантовой медицине».- Донецк, 2003.- С. 158-164.
 32. Gulyar SA, Rudenko IV, The way of impact signal formation on the biological object, neutralization of pathogenic radiation and device for it. Declarative patent of Ukraine, 49253 A. 2002; Bull: 9 (in Russian). Гуляр С.О., Руденко І.В. Спосіб формування сигналу впливу на біологічний об'єкт і нейтралізації патогенних випромінювань і пристрій для його здійснення. Деклараційний патент на винахід 49253 А.- Україна, 2002.- Бюл. № 9.
 33. Gulyar SA, Limansky YP. Pain and color. Kiev-Donetsk: Biosvet, 2004. 122 p. (in Russian). Гуляр С.А., Лиманский Ю.П., Тамарова З.А. Боль и цвет.- Киев-Донецк: БИОСВЕТ, 2004.- 122 с.
 34. Gulyar SA, Kosakovsky AL. eds. BIOPTRON-PILER-light application in medicine. Kiev: BIP NAS of Ukraine and NMAPO of Ministry of Health of Ukraine, 2006. 152 p. (in Ukrainian). Гуляр С.О., Косаковський А.Л. (ред). Застосування БИОПТРОН- ПАЙЛЕР-світла в медицині.- Київ: вид-во ІФБ НАН України та КМАПО МОЗ України, 2006.- 152 с.
 35. Gulyar SA, Limansky YP. Permanent magnetic fields and their use in medicine. Kiev: BIP NAS of Ukraine,

- 2006; 320 p. (in Russian). Гуляр С.А., Лиманский Ю.П. *Постоянные магнитные поля и их применение в медицине.* Киев: Ин-т физиологии им. А.А. Богомольца НАН Украины, 2006. - 320 с.
36. Ho M-W, Knight DP. The acupuncture system and the liquid crystalline collagen fibers of the connective tissues. *Am. J. Chin. Med.* 1998; 26(3-4):251-263.
 37. Iljin VN. Correlation between human geomagnetic activity and heart rate in the Antarctic area. In: *Bul. Ukrain. antarct. center, ed. PF Gozhik.* Kiev: UAC MinSci Ukraine, 1987; 1:255-258 (in Russian). Ильин В.Н. и соавт. *Корреляция между геомагнитной активностью и сердечным ритмом человека в районе Антарктики // Бюл. Укр. антаркт. центру, ред. П.Ф. Гожик.- Київ: УАЦ Міннауки України, 1987.- Вип.1.- С. 255-258.*
 38. Iljin VN, Gulyar SA. Influence of meteorological factors on human body during transatlantic crossings and stay at the Antarctic station "Academician Vernadsky", *ibid.* 1988; 2: 238-244 (in Russian). Ильин В.Н., Гуляр С.А. *Влияние метеорологических факторов на организм человека во время трансатлантических переходов и пребывания на антарктической станции «Академик Вернадский» // Там же.- 1988.- Вип.2.- С. 238-244.*
 39. Isakov VL. The main issues of guideline developments in laser medicine. In: *The use of lasers in biology and medicine.* Kiev, 1995; p. 7-20 (in Russian). Исаков В.Л. *Основные вопросы разработки методических рекомендаций по лазерной медицине.- В кн.: Применение лазеров в биологии и медицине.- Киев, 1995.- С. 7-20.*
 40. Isakov VL. Ultrasound and laser therapy of urogenital tract diseases. In: *Internat. Scientific-practical conf. Medical rehabilitation, balneology and physiotherapy.* Yalta. 1999; p. 282-283 (in Russian). Исаков В.Л. *Ультразвуковая и лазерная терапия заболеваний урогенитального тракта // Междунар. науч.-практ. конф. «Медиц. реабилитация, курортология и физиотерапия».- Ялта.- 1999.- С. 282-283.*
 41. Kalistchuk TM, Matyash MM. *Internat. Scientific-practical conference Medical rehabilitation, balneology and physiotherapy.* Yalta, 1999; p.159-160 (in Russian). Калищук Т.М., Матяш М.М. и соавт. // *Междунар. науч.-практ. конф. «Медиц. реабилитация, курортология и физиотерапия».- Ялта.- 1999.- С. 159-160.*
 42. Katchan AT. *Anatomical and topographical location of corporal acupuncture points, and indications for their use.* Voronezh: University Press. 1990; 144 p. (in Russian). Качан А.Т. и соавт. *Анатомо-топографическое расположение корпоральных точек акупунктуры и показания к их применению.* Воронеж: Изд-во Воронеж. ун-та, 1990.-144 с.
 43. Kirukhin IF, Sarachan TA, Pereskokova II. Biological and medical properties of the water treated by linearly polarized light. N: *Anthology of light therapy, Proc. Kiev: BIP NAS of Ukraine, 2009; p. 480-483.* (in Russian). Кирюхин И.Ф., Сарачан Т.А., Перескокова И.И. *Биологические и лечебные свойства воды, обработанной линейно-поляризованным светом // Антология светотерапии, ИФБ НАНУ, 2009, с. 480-483.*
 44. Kolbun ND. *Theory and practice of information-wave therapy.* Kiev: Biopolis, 1996. 268 p. (in Russian). Колбун Н.Д., Лиманский Ю.П. *Атлас зон информационно-волновой терапии.- Киев: Биополис, 2000.- 112 с.*
 45. Kolbun ND, Limansky YP. *Atlas of information-wave therapy.* Kiev: Biopolis, 2000. 112 p. (in Russian). Колбун Н.Д., Околытенко Н.И. *ИВТ-целительная волна.- Житомир: Вольный.- 2001.- 64 с.*
 46. Kolbun ND, Okolytenko NI. IWT- healing wave. *Zhitomir: Volyn, 2001.* 64 p. (in Russian).
 47. Korotkov KG. *Development of scientific grounds and practical implementation of biotechnical computer measurement systems analysis of gas discharge glow induced by objects of biological nature [Dissertation].* S-Petersburg; 1999. 205 p. (in Russian). Коротков К.Г. *Разработка научных основ и практическая реализация биотехнических измерительно-вычислительных систем анализа газоразрядного свечения, индуцированного объектами биологической природы: Дис. ... д-ра техн. наук. С-Петербурга.- 1999.- 205 с.*
 48. Kulikovich YM, Tamarova ZA. Role of opiate receptors in analgesia evoked by the influence of millimeter range waves of low intensity on acupuncture points. *Medicine prospects.* 1999; 4(3), Part 1:9-14 (in Russian). Куликович Ю.М., Тамарова З.А. *Роль опиатных рецепторов у анальгезии, выключенной дією на точку акупунктури низькоінтенсивних міліметрових хвиль // Медичні перспективи.- 1999.- 4, № 3, ч. 1.- С. 9-14*
 49. Langevin HM, Yandow JA. Relationship of acupuncture points and meridians to connective tissue planes. *Anat. Rec. (New Anat.)*.2002; 269, (6):257-265.
 50. Limansky YP. The hypothesis of acupuncture points as a multimodal system receptors ecocceptive sensitivity. *Fiziol. J.* 1990; 36(4):115-121 (in Russian). Лиманский Ю.П. *Гипотеза о точках акупунктуры как полимодальных рецепторах системы экоцептивной чувствительности // Физиол. журн., 1990.- 36, № 4.- С. 115-121.*
 51. Limansky YP. *Physiology of pain.* Kiev: Health Protection, 1986. 96 p. (in Russian). Лиманский Ю.П. *Физиология боли.- Киев: Здоров'я, 1986.- 96 с.*
 52. Limansky YP. Mechanisms of primary reception of electromagnetic waves in the optical range. *Anthology of light therapy, Proc. Kiev: BIP NAS of Ukraine, 2009; p.93-104* (in Russian). Лиманский Ю.П. *Механизмы первичной рецепции электромагнитных волн оптического диапазона // Антология светотерапии, ИФБ НАНУ, 2009, с. 93-104.*
 53. Limansky YP, Gulyar SA, Tamarova ZA. *BIOPTRON-induced analgesia: 10. Involvement of opioid-ergic system in analgetic effect of polarized light on antinociceptive acupuncture point.* *Anthology of light therapy, Proc. Kiev: BIP NAS of Ukraine, 2009; p. 266-275* (in Russian). Лиманский Ю.П., Гуляр С.А., Тамарова З.А. *Биоптрон-анальгезия: 10. Участие опиоид-эргической системы в анальгетическом эффекте через противоболовую точку акупунктуры // Антология светотерапии, ИФБ НАНУ, 2009, с. 266-275.*
 54. Limansky YP, Gulyar SA, Tamarova ZA. Mechanisms of action of electromagnetic waves in the visible range on living organisms. *Anthology of light therapy, Proc. Kiev: BIP NAS of Ukraine, 2009; p. 105-111* (in Russian). Лиманский Ю.П., Гуляр С.А., Тамарова З.А. *Механизмы действия электромагнитных волн видимого диапазона на живые организмы // Антология светотерапии, ИФБ НАНУ, 2009, с. 105-111.*
 55. Limansky YP, Gulyar SA, Tamarova ZA. *BIOPTRON-analgesia: 1. Analgesia phenomenon of PILER-light BIOPTRON device action on acupuncture points // Anthology of light therapy, Proc. Kiev: BIP NAS of Ukraine, 2009; p. 184-189* (in Russian). Лиманский Ю.П., Гуляр С.А., Тамарова З.А., Костюк О.И., Митрузаева В.А. *БИОПТРОН-анальгезия: 1. Феномен анальгезии при действии ПАЙЛЕР-света аппарата БИОПТРОН на точку акупунктуры // Антология светотерапии, ИФБ НАНУ, 2009, с. 184-189.*
 56. Limonad Y, Ziganov AI. *Live fields of arcitecture.* Obninsk: Titul, 1997. 208 p. (in Russian). Лимонад М.Ю.,

- Цыганов А. И. Живые поля архитектуры.- Обнинск: Титул, 1997.- 208 с.
57. Luvsan G. Traditional and modern aspects of modern reflexology. Moscow: Nauka, 1992, 3rd ed. 576 p. (in Russian). Лувсан Гаваа. Традиционные и современные аспекты современной рефлексотерапии – 3-е изд.- М.: Наука, 1992.- 576 с.
58. Makatz V, Makatz D, Nagajtchuk V, Makatz D. Functional-energy system of biological objects (theory and error of Chinese Zhen-jeou therapy. Vinnitsa: Veles, 2002. 155 p. (in Russian). Макац В., Макац Д., Нагайтчук В., Макац Д. Функционально-энергетическая система биологических объектов (теория и ошибки китайской чжень-цзю терапии. Винница: Велес, 2002.- 155 с.
59. Macheret EL, Samosyuk IZ. Guide on refleksotherapy. Kiev: Vyshcha school, 1989. 479 p. (in Russian). Мачерет Е.Л., Самосюк И.З. Руководство по рефлексотерапии.- К: Выща школа, 1989.- 479 с.
60. Macheret EL, Korkushko AO. Basics of electro and acupuncture. Kiev: Health, 1993. 389 p. (in Russian). Мачерет Е.Л., Коркушко А.О. Основы электро- и акупунктуры.- К.: Здоровья, 1993.- 389 с.
61. Maiserov EE, Blinkov IL. Bioresonance therapy: Method. recommendations, Moscow: Sci-practical Center of traditional medicine and homeopathy. 2000. 27 p. (in Russian). Мейзеров Е.Е., Блинков И.Л., Готовский Ю.В., Королева М.В., Каторгин В.С. Биорезонансная терапия: Метод. рекомендации.- М.: Науч.-практ. центр традиц. медицины и гомеопатии МЗ РФ.- 2000.- 27 с.
62. Muehsam DJ, Pilla AA. The sensitivity of cells and tissues to exogenous fields: effects of target system initial state. Bioelectrochem. Bioenerg. 1999; 48(1):35-42.
63. Musil Y, Novakova O, Kunz K. Modern biochemistry in schemes. Moscow: Mir 1984, 2nd ed. 216 p. (in Russian). Мусил Я., Новакова О., Кунц К. Современная биохимия в схемах. Пер с англ.- 2-е изд.- М.: Мир, 1984.- 216 с.
64. Navratil L, Dilevsky I, Kyplova Y. Polarized light phototherapy by device BIOPTRON. In: Intern. sci-pract. conf. Medicine, rehabilitation, balneology and physiotherapy, Yalta, 1999; p. 135-136 (in Russian). Навратил Л., Дылевски И., Кыплова Я. Фототерапия поляризованным светом аппарата БИОПТРОН.- В кн.: Междунар. науч.-практ. конф. «Медиц. реабилитация, курортология и физиотерапия».- Ялта.- 1999.- С. 135-136.
65. Perehrestenko AP. Immunological evaluation of the effectiveness of polarized application on the body of patients with psoriasis. In: Intern. sci-pract. conf. Medicine, rehabilitation, balneology and physiotherapy, Yalta, 1999; P. 262 (in Russian). Перехрестенко А.П., Барабанчик Т.В., Патока В.В. Иммунологическая оценка эффективности поляризованного света на организм больных псориазом // Там же.- С. 262.
66. Pesikov YS, Rybalko SYa. Atlas of clinical auriculotherapy. Moscow: Medicine, 1990. 256 p. (in Russian). Песиков Я.С., Рыбалко С.Я. Атлас клинической аурикулотерапии.- М.: Медицина, 1990.- 256 с.
67. Poroshina OV. Treatment of neurodermatitis and allergic dermatitis in children with the use of EHF-therapy. In: Intern. Sci. pract. conf. Medicine, rehabilitation, balneology and physiotherapy, Yalta, 1999; p. 209-210 (in Russian). Порошина О.В. Лечение нейродермитов и аллергических дерматитов у детей с применением КВЧ-терапии // Там же.- С. 209-210.
68. Presman AS. Electromagnetic fields and live nature. - M.: Nauka, - 1968.- 288 p. (in Russian). Пресман А.С. Электромагнитные поля и живая природа.- М.: Наука.- 1968.- 288 с.
69. Presman A.S. Electromagnetic alarm in the living nature. Moscow: Soviet radio, 1974. 64 (in Russian). Пресман А.С. Электромагнитная сигнализация в живой природе.- М.: Советское радио.- 1974.- 64 с.
70. Pukavsky KV, Borodyuk OO. Application of weak electromagnetic fields of ultra low frequency for treatment and prophylaxis of vegetative crises. In: Intern. Sci-pract. conf. Medicine, rehabilitation, balneology and physiotherapy. Yalta, 1999; p. 178-179 (in Russian). Пукавський К.В., Бородюк О.О. Використання слабких електромагнітних полів дуже низької частоти для лікування та профілактики вегетосудинних кризів.- В кн.: Междунар. науч.-практ. конф. «Медиц. реабилитация, курортология и физиотерапия».- Ялта, 1999.- С. 178-179.
71. Ragulskaja MV, Kopejkin VV, Lubimov VV. Electromagnetic environmental safety of man. In: Space and Biosphere. Physical fields in biology, medicine and ecology: Intern. Sci-pract. conf. Medicine, rehabilitation, balneology and physiotherapy. Yalta: Partenit, 2001. p. 80-81 (in Russian). Рагульская М.В., Копейкин В.В., Любимов В.В. Электромагнитная экологическая безопасность человека.- В кн.: Космос и биосфера. Физические поля в биологии, медицине и экологии: Тез. докл. Крым. междунар. семинара.- Крым: Партезит, 2001.- С. 80-81.
72. SamoiloVA KA, Obolenskaya KD, Vologdina AV. Single skin exposure to visible polarized light induces rapid modification of entire circulating blood. 1. Improvement of rheologic and immune parameters. In: Proc. of Low-Power Light on Biological Systems IV. Stockholm, Sweden. Sept, 1998; p. 90-103.
73. Samosyuk IZ. System organization of functions and medical rehabilitation. In: Intern. sci and practical. conf. Medicine, rehabilitation, balneology and physiotherapy. Yalta, 1999; p. 30-31 (in Russian). Самосюк И.З. Системная организация функций и медицинская реабилитация.- В кн.: Междунар. науч.-практ. конф. «Медиц. реабилитация, курортология и физиотерапия».- Ялта, 1999.- С. 30-31.
74. Samosyuk IZ. Therapy by Millimeter diapason waves (EHF-therapy, MRI, VPI). In: All Ukrainian assoc. of physiotherapists and health resort. Kiev, 1999, issue 1.2. 199 p. (in Russian). Самосюк И.З., Чухраев Н.В., Шимков Г.Е., Бицон А.В. Терапия электромагнитными волнами миллиметрового диапазона (КВЧ-терапия, МРТ, ИВТ) // Всеукр. асоц. фізіотерапевтів та курортологів, впр.1.2.- Київ: 1999.- 199 с.
75. Sant-Dierdy A. Bioenergy. - Moscow: Fizmatgiz, 1960. 250 p. (in Russian). Сент-Дьерди А. Биоэнергетика.- М.: Физматгиз.- 1960.- 250 с.
76. Shachbasov VG. The nature of biological responses to laser irradiation and the method of determining the change in the energy properties of irradiated objects. In: The use of lasers in biology and medicine. Kiev, 1995. p. 181-186 (in Russian). Шахбазов В.Г. Природа реакций биологических объектов на лазерное облучение и методика определения энергетических свойств облучаемых объектов - В кн.: Применение лазеров в биологии и медицине. - Киев, 1995.- С. 181-186.
77. Starchenko MG, Anufriev VP, Anufrieva EI, Putina OP. The thought and the heart. Arktur, 1999; 17:19-24 (in Russian). Старченко М.Г., Ануфриев В.П., Ануфриева Е.И., Путина О.П. Мысль и сердце // Арктур.- 1999.- № 17.- С. 19-24.
78. Syt'ko SP, Skripnik YA, Yanenko AF. Apparatus support of quantum medicine modern technology. Kiev: Fada,

1999. 199 p. (in Russian). Ситько С.П., Скрипник Ю.А., Яненко А.Ф. *Аппаратурное обеспечение современных технологий квантовой медицины.* - К.: ФАДА, 1999.- 199 с.
79. Vajsyn' U. Sketches of Eastern medicine. St. Petersburg: Borey Art, 1998. 193 p. (in Russian). Вэйсинь У. *Очерки восточной медицины.* Санкт-Петербург: Борей Арт, 1998.- 193 с.
80. Ulashchyk VS. Current status and future directions of phototherapy. In: BIOPTRON devices - action and therapeutic application. Minsk, Biznesofset. 2001; p. 8-21 (in Russian). Улащик В.С. *Современное состояние и перспективные направления фототерапии – В кн.: Аппараты БИОПТРОН – действие и лечебное применение.* - Минск: Бизнесофсет.- 2001.- С. 8-21
81. Curl RF, Kroto H, Smalley RE. The Nobel Prize in Chemistry 1996. Nobelprize.org. Nobel Media AB 2014. Web. Accessed 31 Aug 2017. http://www.nobelprize.org/nobel_prizes/chemistry/laureates/1996/.
82. Koruga D, Hameroff S, Loutfy R, Withers J, Sundere-shan M. Fullerene C60: History, Physics, Nanobiology, Nanotechnology. 1993; Amsterdam: Elsevier (North-Holland). 381 p.
83. Koruga D. Nanophotonic filter based on C60 for hyperpolarized light. Int. and European Pat. App. PCT/EP2016/063174. 2016. Applicant: Fieldpoint, ZEPTER GROUP filed June 09 2016 2015 and issued October 28, 2016
84. Koruga, D. 2017. Hyperpolarized Light : Fundamentals of nano medical photonics. Belgrade: Zepter book world. 306 p. (In Serbian).
85. Gulyar SA, Tamarova ZA. Modification of Polychromatic Linear Polarized Light by Nanophotonic Fullerene and Graphene Filter Creates a New Therapeutic Opportunities. J. of US-China Medical Science. 2017; 14(5), Sept.-Oct. (Serial Number 109): 173-191.
86. Gulyar SA, Tamarova ZA. Anti-pain and sedative action of polychromatic polarized light which passed through nanomodification by carbon nanofilters. In: Proc. XLVII Int. Sci-Pract. conf. Oct, 12-14, 2017. Kiev, 2017; p. 95-97 (in Russian). Гуляр СА, Тамарова ЗА. *Противоболевое и седативное действие полихроматического поляризованного света, получившего наномодификацию углеродным наночастицами.* Матер. XLVII Междунар. науч-практ. конф. 12-14 окт. 2017, Киев, 2017, с.95-97.

THERMAL PROCESSES IN HUMAN SKIN UPON IRRADIATION BY LASER PULSES

N.G. Kokodii

Dr. Sci. (Phys.-Math.), Prof.
Department of Quantum Radio-Physics
V.N. Karazin Kharkov National University
4 Svobody Sq., Kharkiv, 61022, Ukraine
tel: +38 (057) 707-51-57
e-mail: kokodiyng@gmail.com
ORCID 0000-0003-1325-4563

V.A. Timaniuk

Cand. Sci. (Phys.-Math.), Prof.
Department of Physics
National University of Pharmacy
53 Pushkinsraya St., Kharkiv, 61002, Ukraine
tel: +38 (057) 771-81-59
e-mail: physics@nuph.edu
ORCID 0000-0003-0689-6074

A.M. Korobov

Cand. Sci. (Phys.-Math.), Head of the laboratory
Science and Research Laboratory of Quantum Biology
and Quantum Medicine
V.N. Karazin Kharkiv National University
6 Svobody Sq., Kharkiv, 61022, Ukraine
tel: +38 (057) 707-51-91
e-mail: amkorobov@karazin.ua
ORCID 0000-0001-8237-7159

The mathematical model of the process of heating the surface of the skin and its inner layers of short laser pulses. Duration of pulses is much less than time setting temperature in the body. It is using the solution of the equation of thermal conductivity for semi-infinity of the body when it is heated by flow of the electromagnetic radiation. Heat exchange with the outside space is not happening for the duration of a pulse, so the surface of the body can be considered isolated. The body temperature is rising almost linear. After the end of the pulse it decreases slowly (thermal time constant is 20 min approximately).

By heating a series of pulses the temperature increases in the same way as by heating of continuous radiation.

It is calculated the increase temperature of body by heating pulses 10 ms, amplitude 10 W, period of 50 ms. The average radiated power is 2 W. The temperature of body within 5 s rises to 300 °C.

Key words: irradiation by laser pulses, human skin, thermal processes.

ТЕПЛОВІ ПРОЦЕСИ В ШКІРІ ЛЮДИНИ ПІД ЧАС ОПРОМІНЕННЯ ЛАЗЕРНИМИ ІМПУЛЬСАМИ

М.Г. Кокодій^{1,2}, В.О. Тіманюк², А.М. Коробов¹

¹Харківський національний університет імені В. Н. Каразіна, м. Харків, Україна;

²Національний фармацевтичний університет, м. Харків, Україна

Запропоновано математичну модель процесу нагрівання поверхні шкіри і її внутрішніх шарів короткими лазерними імпульсами. Тривалість імпульсів набагато менше часу встановлення температури. Було використано розв'язання рівняння теплопровідності для напівбескінечного тіла при нагріванні потоком електромагнітного випромінювання. За час дії імпульсу теплообмін з зовнішнім середовищем не відбувається, тому поверхня тіла може вважатися теплоізованою. Температура тіла зростає майже за лінійним законом. Після закінчення імпульсу температура повільно знижується (теплова постійна часу становить приблизно 20 хв.).

При нагріванні серією імпульсів температура тіла збільшується так само, як при нагріванні безперервним випромінюванням.

Обчислено підвищення температури тіла під час нагрівання імпульсами тривалістю 10 мс кожний, амплітудою 10 Вт, з періодом 50 мс. Середня потужність складає 2 Вт. Температура тіла протягом 5 с піднімається до 300 °C.

Ключові слова: імпульсне лазерне випромінювання, шкіра людини, теплові процеси.

ТЕПЛОВЫЕ ПРОЦЕССЫ В КОЖЕ ЧЕЛОВЕКА ПРИ ОБЛУЧЕНИИ ЛАЗЕРНЫМИ ИМПУЛЬСАМИ

Н.Г. Кокодий^{1,2}, В.А. Тиманюк², А.М. Коробов¹

¹Харьковский национальный университет имени В.Н.Каразина, г. Харьков, Украина

²Национальный фармацевтический университет, г. Харьков, Украина

Предложена математическая модель процесса нагрева поверхности кожи и ее внутренних слоев короткими лазерными импульсами, длительность которых намного меньше времени установления температуры в теле. Используется решение уравнения теплопроводности для полубесконечного тела при нагреве потоком электромагнитного излучения. За время действия импульса теплообмен с внешним пространством не происходит, поэтому поверхность тела можно считать изолированной. Температура тела растет почти по линейному закону. После окончания импульса она медленно уменьшается (тепловая постоянная времени около 20 мин).

При нагреве серией импульсов температура увеличивается так же, как при нагреве непрерывным излучением.

Вычислен рост температуры тела при нагреве импульсами длительностью 10 мс, амплитудой 10 Вт, идущих с периодом 50 мс. Средняя мощность излучения 2 Вт. Температура тела в течение 5 с повышается до 300 °С.

Ключевые слова: импульсное лазерное облучение, кожа человека, тепловые процессы.

Introduction

Research of thermal processes occurring under the action of laser radiation on humans, given the opportunity to develop new therapies for many diseases. However, the complexity of the object of exposure (skin, subcutaneous tissues, circulatory organs) cause a need for further study of phenomena that occur at the same time. Theoretical and experimental research in this direction are made in the Laboratory of Quantum Biology and Quantum Medicine KNU. In works [1, 2], which were presented at the conferences "Lasers in medicine and biology", investigates the thermal processes when exposed to human skin and continuous optical radiation pulses, the duration of which is more time setting the temperature in the object of influence.

In this work the calculations of the heating of the skin and subcutaneous layers in the case of short optical radiation pulses.

Mathematical model

Mathematical model of the structure of the skin adopted is the same as in works [1, 2]. It is shown in Fig. 1 and corresponds to the model proposed in the paper [3]. In the skin there are three parts. The upper part is the epidermis is a multilayered epithelium, the outer layer which is the stratum corneum. The bottom layer of the epidermis rests on the basement membrane. It contains melanocytes cells that protect skin from the harmful effects of sunlight. The inner skin is the dermis has a thickness of from 0.5 mm to 5 mm and in it are the blood vessels.

The thickness of epidermis is approximately equal to 0.06 mm. The fraction of energy absorbed in this layer is small, so the presence of a layer can not be ignored, and to consider the fabric of a homogeneous body. Therefore, the problem of heating a semi-infinite body by optical radiation penetrating into it in some depth.

The penetration depth of radiation in the ultraviolet region of a few micrometers, in a green about 1 mm, in the red region of the depth of penetration increased to 20–30 mm. Short-wave infrared radiation with wavelengths less than 1.5 μm penetrates to 30–70 mm.

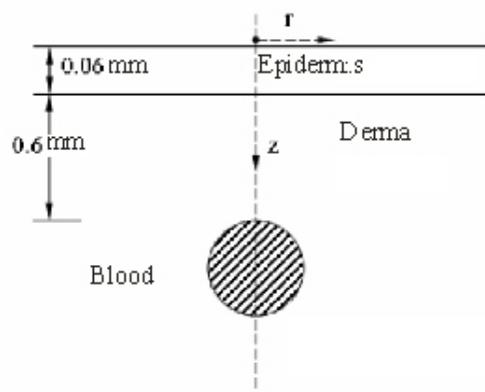

Fig. 1. Model of the structure of the skin

The change of radiation intensity along the z-axis (into the body) is described by the Bouguer law:

$$I(z) = I_0 e^{-\frac{z}{\delta}},$$

where δ – the penetration depth of the radiation level $1/e$.

Volume density of heat sources is determined by the formula:

$$S(z, t) = \frac{I_0}{\delta} e^{-\frac{z}{\delta}}.$$

The task is described in works [1, 2], took into account the removal of heat deep into the body, the tissue conductivity and blood flow. It was shown that when heating of the skin continuous emission temperature is set slowly for about 20 min. So when heated with short pulses, the duration of which is much less time setting temperature, the withdrawal of heat from the heated region can not ignore this area be treated as insulated. The heat conduction equation in this case looks like this:

$$\frac{\partial^2 T(z,t)}{\partial z^2} - \frac{1}{a} \frac{\partial T(z,t)}{\partial t} = -\frac{S(z,t)}{k} \quad (1)$$

It differs from the equation in work [1] lack of the right part of the expression describing the dissipation of heat by blood flow.

Initial and boundary conditions remain the same:

$$T(z,0) = 0, \quad \frac{\partial T(0,t)}{\partial z} = 0, \quad T(\infty,t) = 0.$$

They mean the absence of heat exchange between the heated surface and the environment and zero temperature in the depth of the body.

In the calculations we used the following data about the thermophysical parameters of the skin [3]: $k = 0.5 \text{ W/(m K)}$, $c = 3500 \text{ J/(kg K)}$, $\rho = 1100 \text{ kg/m}^3$.

The parameters of laser radiation were adopted as follows: pulse power $P_0 = 30 \text{ W}$; pulse duration $t_p = 10 \text{ ms}$; repetition period of pulses $T = 20 \dots 50 \text{ ms}$; beam diameter $D = 1 \text{ mm}$; the depth of penetration of the radiation in the level $1/e$ ($d = 10 \text{ mm}$).

The solution of equation (1) looks like this:

$$T(z,t) = \begin{cases} T_0(z,t) & \text{if } 0 \leq t \leq t_p \\ T_0(z,t) - T_0(z,t - t_p) & \text{if } t > t_p \end{cases} \quad (2)$$

where

$$T_0(z,t) = \frac{P_0 \delta}{k S} \left\{ \frac{2\sqrt{at}}{\delta} \operatorname{ierfc}\left(\frac{z}{2\sqrt{at}}\right) - e^{-\frac{z}{\delta}} + \frac{1}{2} e^{\frac{at}{\delta^2}} \left[e^{-\frac{z}{\delta}} \operatorname{erfc}\left(\frac{\sqrt{at}}{\delta} - \frac{z}{2\sqrt{at}}\right) + e^{\frac{z}{\delta}} \operatorname{erfc}\left(\frac{\sqrt{at}}{\delta} + \frac{z}{2\sqrt{at}}\right) \right] \right\}.$$

$\operatorname{erfc}(x)$ is the additional error function,

$$\operatorname{ierfc}(x) = \frac{1}{\sqrt{\pi}} e^{-x^2} - x \operatorname{erfc}(x) \text{ is integral of the ad-}$$

ditional error functions, $a = \frac{k}{c\rho}$ is thermal diffusivity

coefficient of the biological tissue, S – cross sectional area of the beam.

The time course of temperature at different depths calculated by the formula (2) for a single pulse with the parameters specified above, shown in Fig. 2.

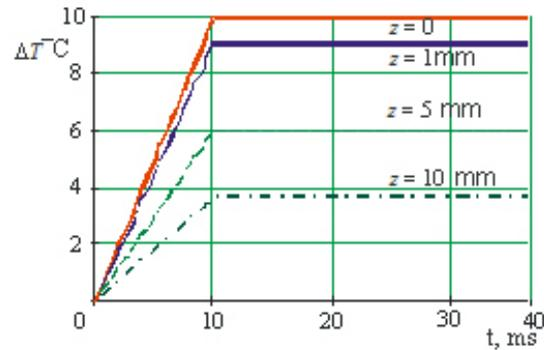

Fig. 2. The time course of temperature during heating of biological tissue by the radiation pulse

For the duration of the pulse (10 ms), the temperature increases almost linearly. In fact, it is the exponent with a time constant of 300 s. However, on a very small initial part it differs little from a straight line. After the pulse occurs, the cooling fabric is also exponential. On the chart the decrease in temperature imperceptible, as it occurs slowly (with a time constant of 300 s).

As for the duration of the pulse, the heated heat exchange area with the environment does not occur; the maximum heating temperature is determined by the absorbed energy and heat capacity of the heated volume. It can be estimated by a simple formula:

$$\Delta T_{\max} = \frac{E}{mc} = \frac{P_0 t_p}{c \rho \delta S}, \quad (3)$$

where E – pulse energy, P_0 – pulse power, t_p – pulse duration, S – cross sectional area of the beam, c – specific heat, ρ – density.

In Fig. 3 shows the temperature distribution along the z coordinate is the depth in tissue. His profile fits the profile distribution of radiation intensity according

to the law $e^{-\frac{z}{\delta}}$. The radius of the radiation intensity and the temperature in our problem is constant.

The temperature and its distribution in space is determined only by pulse energy. It is independent of pulse duration. Even for $t_p = 1 \text{ s}$ the graphics $T(z,t)$ are the same as in Fig. 2 and 3. It is due what heat exchange to external volume is absent.

By heating the target with a series of pulses temperature at the end of each pulse increases by a certain

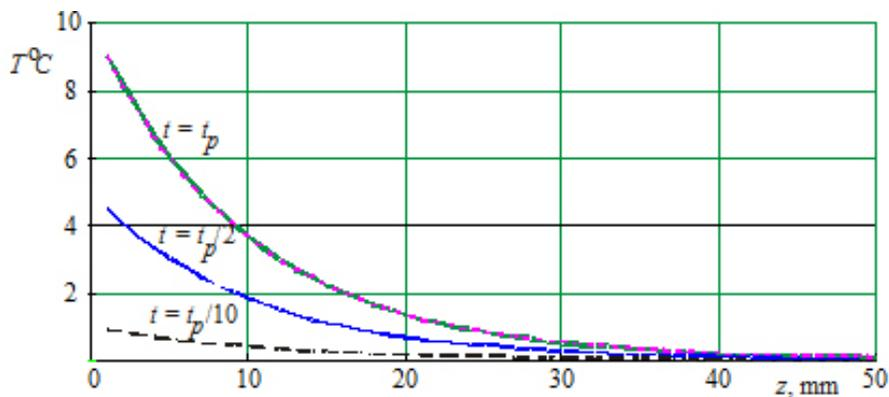

Fig. 3. Temperature distribution in biological tissue at depth

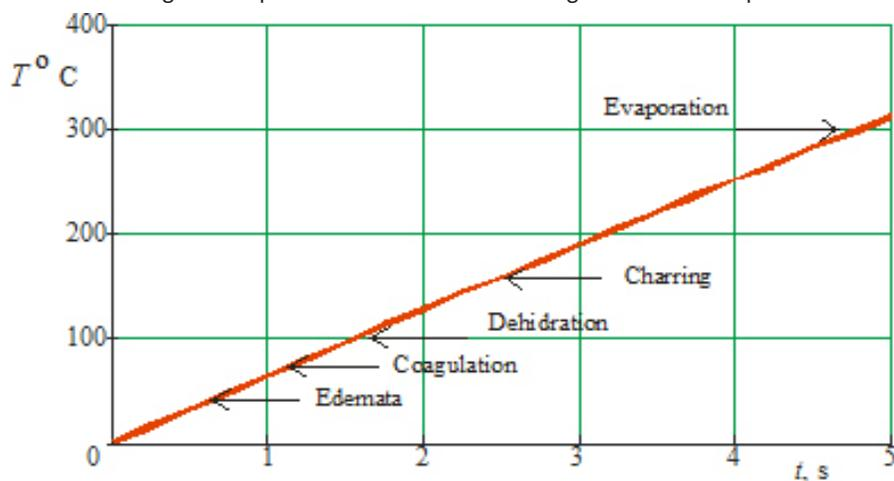

Fig. 4. Heating of biological tissue with a pulsed radiation (average power is 2 W)

amount ΔT , while the exposure time is much less than the thermal time constant τ . Therefore, the heating rate can be adjusted by changing the duty cycle (the repetition period of pulses). This changes the average radiation power.

In Fig. 4 shows the course of heating of biological tissue to pulsed-modulated radiation with an average power of 2 W (pulse duration is 10 ms, pulse power is 10 W, the period is 50 ms). Such power is enough for a few seconds the temperature of the tissue increased to 300°C by increasing the duty cycle twice the average power is reduced twice. This way you can set the wattage at which the temperature of the surface layers of tissue during, for example, 1 s will rise to the temperature required for the doctor's work.

Conclusions

1. The temperature of the biological tissue when it is heated single laser pulse is determined by the pulse energy and the heated volume (beam diameter and penetration depth of radiation in tissue). The duration of the radiation pulse is not a function.

2. When heating of tissue pulse-modulated laser radiation, the degree of heat it is convenient to regulate the change of the duty cycle (the repetition period of pulses at a constant pulse duration of radiation).

References

1. Kokodiy NG, Korobov AM, Timaniuk VA. Thermal processes in the human skin irradiated with LEDs. Materialy XLV Mezhdunar. nauch.-prakt. konf. Primenenie lazerov v meditsine i biologii [Proceedings of XLV International Sc. and Pract. Conf. Application of Lasers in Medicine and Biology]; 2016 Oct 6-8; Kharkiv-Bukovel. Kharkiv: Petrov V.V. Publ.; 2016; p. 124-8. (in Russian)
2. Kokodiy NG, Korobov AM, Timaniuk VA. Limit cases of exposure to human skin of optical radiation. aterialy XLVI Mezhdunar. nauch.-prakt. konf. Primenenie lazerov v meditsine i biologii [Proceedings of XLVI International Sc. and Pract. Conf. Application of Lasers in Medicine and Biology]; 2017 May 25-27; Kharkiv. Kharkiv: Petrov V.V. Publ.; 2017; p. 166-8. (in Russian)
3. Pushkareva AE. Metodyi matematicheskogo modelirovaniya v optike biotkani: uchebnoe posobie [Methods of mathematical modeling in biotink optics: a manual]. St.Pb: St.PbSUITMO Publ.; 2008. 103 p. (in Russian)

CLINICAL PHOTOMEDICINE

PHOTOBIOLOGY AND EXPERIMENTAL
PHOTOMEDICINE

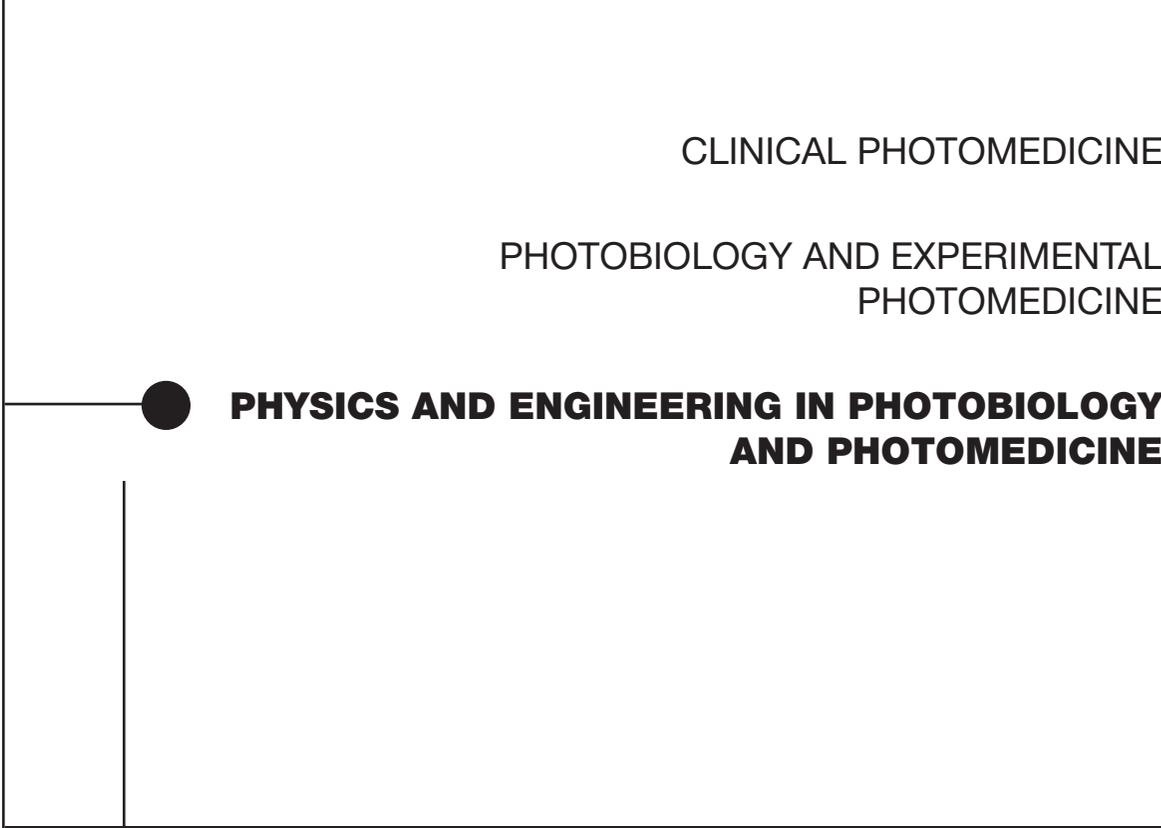

**PHYSICS AND ENGINEERING IN PHOTOBIOLOGY
AND PHOTOMEDICINE**

**PHOTOTHERAPEUTIC HARDWARE COMPLEX FOR REHABILITATION,
PREVENTION AND TREATMENT OF DISEASES OF THE HUMAN
CENTRAL NERVOUS SYSTEM**

A.M. Korobov, M.F. Posokhov, M.F. Korobov., O.V. Kozyr

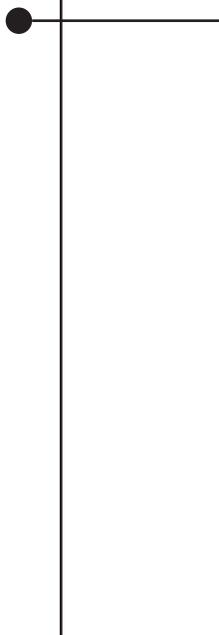

PHOTOTHERAPEUTIC HARDWARE COMPLEX FOR REHABILITATION, PREVENTION AND TREATMENT OF DISEASES OF THE HUMAN CENTRAL NERVOUS SYSTEM

A.M. Korobov

*Cand. Sci. (Phys.-Math.), Head of the laboratory
Science and Research Laboratory of Quantum Biology
and Quantum Medicine
V.N. Karazin Kharkiv National University
6 Svobody Sq., Kharkiv, 61022, Ukraine
tel.: +38 (057) 707-51-91
e-mail: amkorobov@karazin.ua
ORCID 0000-0001-8237-7159*

V.A. Korobov

*Researcher
Research and Production Medical and Biological
Corporation “Laser and Health”
1 Zhukovskogo Av., off. 99, Kharkiv, 61085, Ukraine
tel.: +38 (050) 031-98-62
e-mail: korobov_vsevolod@bigmir.net
ORCID 0000-0002-2848-0929*

M.F. Posokhov

*Cand. Sci. (Med.), Docent, Head of the department
Department of Functional Neurosurgery with a group of
pathomorphology
“Institute of Neurology, Psychiatry and Narcology of the
NAMS of Ukraine” State Institution
46 Akademika Pavlova St., Kharkiv, 61068, Ukraine
tel.: +38 (050) 677- 77-53
e-mail: posohov@bk.ru
ORCID 0000-0003-3361-5522*

O.V. Kozyr

*Junior Researcher
Science and Research Laboratory of Quantum Biology
and Quantum Medicine
V.N. Karazin Kharkiv National University
6 Svobody Sq., Kharkiv, 61022, Ukraine
tel.: +38 (057) 707-51-91
e-mail: kbkm@karazin.ua
ORCID 0000-0001-9854-9170*

Introduction. The significant prevalence of vascular diseases of the brain, the complexity of dysfunction, put the problems of their treatment, rehabilitation and prevention into the focus of attention of modern neurology. A stroke occurs in the United States every 45 seconds. Approximately 750,000 people a year suffer from a stroke in the United States. According to statistics from the Ministry of Health of Ukraine, more than 110,000 primary strokes are recorded annually in the country. No less serious disease of the human central nervous system is Alzheimer’s disease. Each year, more than 500,000 Americans die from this disease, making it the third leading cause of death in the United States. Traffic accidents, local military conflicts, some sports form a very numerous specific group of patients with craniocerebral injuries.

Aim — to develop a phototherapeutic hardware complex for the prevention, treatment and rehabilitation of vascular, inflammatory, degenerative, post-traumatic and other brain diseases that are difficult amenable to medical treatment including pharmacoresistant indomitable pain syndromes.

Materials and methods. The low-intensity electromagnetic radiation of the optical range of the spectrum and the magnetic field of a permanent magnet are physical factors that are used in phototherapeutic complex devices.

Results. A phototherapy apparatus complex has been developed for the prevention, treatment and rehabilitation of vascular, inflammatory, degenerative, post-traumatic and other brain diseases that are difficult to treat with drugs. The phototherapeutic hardware complex includes three devices: the modified photon-magnetic apparatus Korobov-Posokhov “Barva-CNS/FM”, the photon-magnetic matrices A.Korobov - V.Korobov “Barva-Laryngologist/FM” and flexible photon-magnetic matrices A.Korobov - V.Korobov “Barva-Flex/24FM”.

Conclusions. The presented clinical observations obtained using the developed phototherapeutic hardware complex for the treatment and prevention of diseases of the brain indicate high efficacy and safety of long-term low-intensity phototherapy in patients with dyscirculatory encephalopathy, with suffered ischemic and hemorrhagic strokes, with hypertensive disease.

Key words: phototherapy hardware complex, brain diseases, prevention, treatment, rehabilitation, electromagnetic radiation of the optical range of the spectrum, LEDs, magnets.

ФОТОТЕРАПЕВТИЧНИЙ АПАРАТНИЙ КОМПЛЕКС ДЛЯ ПРОФІЛАКТИКИ, ЛІКУВАННЯ ТА РЕАБІЛІТАЦІЇ ЗАХВОРЮВАНЬ ЦЕНТРАЛЬНОЇ НЕРВОВОЇ СИСТЕМИ ЛЮДИНИ

А.М.Коробов¹, М.Ф.Посохов², В.А.Коробов³, О.В.Козир¹

¹Харківський національний університет імені В. Н. Каразіна, м. Харків, Україна;

²ДУ «Інститут неврології, психіатрії та наркології НАМН України», м. Харків, Україна;

³Науково-виробнича медико-біологічна корпорація «Лазер і Здоров'я», м. Харків, Україна

Вступ. Значна поширеність судинних захворювань головного мозку, складність порушень функцій, ставлять проблеми їх лікування, реабілітації та профілактики в центр уваги сучасної неврології. У США кожні 45 секунд трапляється інсульт. Приблизно 750000 осіб на рік страждають від інсульту в США. За даними статистики МОЗ України, в країні щорічно фіксується понад 110000 первинних інсультів. Не менш серйозним захворюванням центральної нервової системи людини є хвороба Альцгеймера. Щороку від цієї хвороби помирає понад 500 тисяч американців, роблячи її третьою провідною причиною смерті в США. Дорожньо-транспортні пригоди, локальні військові конфлікти, деякі види спорту формують дуже велику специфічну групу пацієнтів з черепно-мозковими травмами.

Мета — розробка фототерапевтичного апаратного комплексу для профілактики, лікування та реабілітації судинних, запальних, дегенеративних, посттравматичних та інших захворювань головного мозку, які важко піддаються медикаментозному лікуванню.

Матеріали та методи. Низькоінтенсивне електромагнітне випромінювання оптичного діапазону спектра і магнітне поле постійного магніту — фізичні фактори, які використовуються в апаратах фототерапевтичного комплексу.

Результати. Розроблено фототерапевтичний апаратний комплекс для профілактики, лікування та реабілітації судинних, запальних, дегенеративних, посттравматичних та інших захворювань головного мозку, які важко піддаються медикаментозному лікуванню. Фототерапевтичний апаратний комплекс включає три апарати: модифікований фотонно-магнітний апарат Коробова-Посохова «Барва-ЦНС/ФМ», фотонно-магнітні матриці Коробова А.-Коробова В. «Барва-Ларинголог/ФМ» і гнучкі фотонно-магнітні матриці Коробова А.-Коробова В. «Барва-Флекс/24ФМ».

Висновки. Представлені клінічні спостереження, отримані з використанням розробленого фототерапевтичного апаратного комплексу для лікування і профілактики захворювань головного мозку, свідчать про високу ефективність та безпечність тривалої низькоінтенсивної фототерапії у хворих з дисциркуляторною енцефалопатією, з перенесеними ішемічними і геморагічними інсультами, з гіпертонічною хворобою.

Ключові слова: фототерапевтичний апаратний комплекс, захворювання головного мозку, профілактика, лікування, реабілітація, електромагнітне випромінювання оптичного діапазону спектра, світлодіоди, магніти.

ФОТОТЕРАПЕВТИЧЕСКИЙ АППАРАТНЫЙ КОМПЛЕКС ДЛЯ ПРОФИЛАКТИКИ, ЛЕЧЕНИЯ И РЕАБИЛИТАЦИИ ЗАБОЛЕВАНИЙ ЦЕНТРАЛЬНОЙ НЕРВНОЙ СИСТЕМЫ ЧЕЛОВЕКА

А.М.Коробов¹, Н.Ф.Посохов², В.А.Коробов³, Е.В.Козырь¹

¹Харьковский национальный университет имени В.Н.Каразина, г. Харьков, Украина;

²ГУ «Институт неврологии, психиатрии и наркологии НАМН Украины», г. Харьков, Украина;

³Научно-производственная медико-биологическая корпорация «Лазер и Здоровье», г. Харьков, Украина

Введение. Значительная распространенность сосудистых заболеваний головного мозга, сложность нарушений функций, ставят проблемы их лечения, реабилитации и профилактики в центр внимания современной неврологии. В США каждые 45 секунд случается инсульт. Примерно 750000 человек в год страдают от инсульта в США. По данным статистики Минздрава Украины, в стране ежегодно фиксируется более 110000 первичных инсультов. Не менее серьезным заболеванием центральной нервной системы человека является болезнь Альцгеймера. Каждый год от этой болезни умирает более 500 тысяч американцев, делая ее третьей ведущей причиной смерти в США. Дорожно-транспортные происшествия, локальные военные конфликты, некоторые виды спорта формируют весьма многочисленную специфическую группу пациентов с черепно-мозговыми травмами.

Цель — разработка фототерапевтического апаратного комплекса для профилактики, лечения и реабилитации сосудистых, воспалительных, дегенеративных, посттравматических и других заболеваний головного мозга, которые трудно поддаются медикаментозному лечению, в том числе фармакорезистентных неукротимых болевых синдромов.

Материалы и методы. Низкоинтенсивное электромагнитное излучение оптического диапазона спектра и магнитное поле постоянного магнита — физические факторы, которые используются в аппаратах фототерапевтического комплекса.

Результаты. Разработан фототерапевтический аппаратный комплекс для профилактики, лечения и реабилитации сосудистых, воспалительных, дегенеративных, посттравматических и других заболеваний головного мозга, которые трудно поддаются медикаментозному лечению. Фототерапевтический аппаратный комплекс включает три аппарата: модифицированный фотонно-магнитный аппарат Коробова-Посохова «Барва-ЦНС/ФМ», фотонно-магнитные матрицы Коробова А.-Коробова В. «Барва-Ларинголог/ФМ» и гибкие фотонно-магнитные матрицы Коробова А.-Коробова В. «Барва-Флекс/24ФМ».

Выводы. Представленные клинические наблюдения, полученные с использованием разработанного фототерапевтического аппаратного комплекса для лечения и профилактики заболеваний головного мозга, свидетельствуют о высокой эффективности и безопасности длительной низкоинтенсивной фототерапии у больных с дисциркуляторной энцефалопатией, с перенесенными ишемическими и геморрагическими инсультами, с гипертонической болезнью.

Ключевые слова: фототерапевтический аппаратный комплекс, заболевания головного мозга, профилактика, лечение, реабилитация, электромагнитное излучение оптического диапазона спектра, светодиоды, магниты.

Introduction

Diseases of the central nervous system are rank among the top three leaders in the list of pathologies that have upsetting rates of the mortality, disablement for a long time and invalidization of patients. The significant prevalence of vascular diseases of the brain, the complexity of dysfunction, put the problems of their treatment, rehabilitation and prevention into the focus of attention of modern neurology.

The most formidable among the diseases of the central nervous system are vascular diseases of the brain. The Statistical Committee of the American Heart Association (AHA) shows that a stroke occurs in the United States every 45 seconds. This means that approximately 750,000 people a year suffer from a stroke in the United States. Of these cases, 87% are ischemic strokes, in which most people can be saved from death. The American Heart Association states that there are about 5.4 million people today who have had a stroke in the US. [1]

According to statistics from the Ministry of Health of Ukraine, more than 110,000 primary strokes are recorded annually in the country, after which death is registered in 37% of cases. More than 20% of patients become disabled, and only 10–20% return to work. [2] Because of this, the rehabilitation of stroke patients is a serious medical and social problem for all countries.

Timely, pathogenetically directed therapy at the stage of reversible defects in the acute period of stroke and in case of chronic inefficiency of cerebral circulation is the most promising direction in modern approaches to the treatment of this disease. Today's advances in surgery and pharmacotherapy in the treatment of stroke in the acute period are indisputable. However, at the stage of rehabilitation of patients with stroke, as well as for the prevention of this pathology, it is impossible to do without physiotherapy. And here, the undisputed leader is phototherapy (photobiomodulation), in which the low-intensity electromagnetic radiation of the visible and infrared ranges

of the spectrum of various sources (lasers, LEDs, gas discharge lamps, incandescent lamps, etc.) is used as a therapeutic factor. [3,4,5,6]

No less serious disease of the human central nervous system is Alzheimer's disease — a common chronic, expensive, debilitating neurodegenerative disease characterized by progressive loss of memory and cognitive dysfunction. Alzheimer's disease is currently observed in 5.4 million Americans [7]. According to forecasts, in the next 20 years, every fourth inhabitant of the United States will have a diagnosis: Alzheimer's disease. Each year, more than 500,000 Americans die from this disease, making it the third leading cause of death in the United States [8,9]. Worst of all, there is no effective medicine for this disease.

The first researches conducted in a number of scientific and practical centers showed the perspective of using low-intensity electromagnetic radiation of the red and infrared ranges of the spectrum (photobiomodulation) to treat Alzheimer's disease [10,11]. A group of patients who were treated for Alzheimer's disease using photonic technology had improved cerebral microcirculation leading to a permanent (from 1 to 7 years) reduction of dementia and reconstruction of cognitive functions [12,13].

Traffic accidents, local military conflicts, some sports form a very numerous specific group of patients with craniocerebral injuries. Today, researches on the use of photobiomodulation for treating patients with craniocerebral injuries are usually few, but the results shows that restoration of microcirculation, rheological properties of blood, immunomodulatory and anti-inflammatory effect of photobiomodulation may be effective in treating these patients [11,14,15,16].

The aim of this work was to develop a phototherapeutic hardware complex for the prevention, treatment and rehabilitation of vascular, inflammatory, degenerative, post-traumatic and other brain diseases that are difficult amenable to medical treatment including pharmacoresistant indomitable pain syndromes.

Materials and methods

Scientifically proven fact is the assertion that almost all pathological processes in the human body begin with the first, non-specific phase — a defect of the microcirculation of blood [17,18].

It is natural to assume that any treatment process of any pathology, including neurological, should begin with the reconstruction of microcirculation of blood.

This problem is perfectly solved by phototherapy (photobiomodulation). The universalism of the therapeutic effect of light is based on its ability to exert a powerful regulating effect on the main physiological link of the body's activity — the microcirculation of blood and lymph [19]. The light of the visible and infrared ranges of the spectrum normalizes the work of the regulatory systems of the human body (immune, endocrine and central nervous) [20,21,22].

Under the action of visible and infrared light, the elasticity of blood vessel walls increases, the red blood cell elasticity increases, the oxygen transport function of the blood increases, the activity of cell membranes increases, angiogenesis accelerates, lipid peroxidation decreases, the rheological blood parameters are normalized, the formation of ATP in mitochondria is reduced, which increases the bioenergy potential of cells [23]. The light has an anti-inflammatory, anti-edema, healing and analgesic effect, normalizes blood pressure, has a radioprotective and photoreactivating effect [24].

The light has no contraindications and negative side effects and can be used to treat and prevent the most common human diseases, including oncological ones. The end result of exposure to the light of the visible and infrared ranges of the spectrum is an increase of the resistance of the organism and an expansion of the limits of its adaptation, i.e. resistance to various diseases [25].

On the basis thereof, more than 10 years ago, the "Barva-CNS" Posokhov-Korobov unit was developed for phototherapy of diseases of the central nervous system [26] by transcranial exposure to the human brain. The unit consists of two blocks — a photonic block and block of power and control. The photonic block of the units was made in the form of a helmet. Geometrical size of the helmet were chosen in such a way that LED irradiators could affect the entire area of the hairy part of the patient's head. The first units used light sources emitting in the red and infrared regions of the visible spectrum. This radiation invades biological tissues as deeply as possible. The long-term experience of using "Barva-CNS" units in clinical practice has shown that in most cases a good, stable result of treatment is achieved. Particularly high efficiency is observed when using of the unit for the rehabilitation and prevention of neurological diseases in sanatorium-resort practice.

The second important physical factor used in physiotherapy is the constant magnetic field. It has both direct and reflex effects on various organs and

systems. The basis of the action of the magnetic field on the body are the primary physical and chemical changes that appear in various biological structures under its influence. By causing a building of the liquid crystal structures of biological membranes and intracellular biological structures, static magnetic fields affect their functional activity [27].

The magnetic field, affecting the human body, leads to the following effects:

- changes biochemical and biophysical processes with the subsequent normalization of cell membrane permeability and acceleration of redox reactions;
- changes the rate of flow of free radical reactions and hydration of ions;
- improves the rheological qualities of blood;
- stimulates the opening of the reserve capillaries;
- stimulates tissue regeneration;
- reduces the formation of metHb, which improves tissue respiration;
- changes the conformation and orientation of macromolecules;
- changes the physical and chemical properties and structure of water;
- improves the condition of the vascular endothelium;
- eliminates vegetovascular disorders;
- has anti-inflammatory and analgesic effect.

These properties of light and magnetic field determine their high efficiency in the treatment and prevention of the absolute majority of human diseases.

Results

In view of the foregoing, we have developed a phototherapy hardware complex, which allows treatment of the most common and orphan diseases of the brain by exposure to infrared and visible spectral radiation in combination with a constant magnetic field.

Modified photon-magnetic apparatus Korobov-Posokhov "Barva-CNS/FM"

The base apparatus of the phototherapeutic hardware complex for the rehabilitation, prevention and treatment of diseases of the human central nervous system is the modified photon-magnetic apparatus Korobov-Posokhov "Barva-CNS/FM". The previous model of the device for phototherapy of diseases of the central nervous system of Posokhov-Korobov "Barva-CNS", described in detail in the work [26], has undergone significant changes.

First, the spectral range of the emitting LEDs of the photon block has expanded in the direction of short wavelengths up to 400 nm. The expediency of such a step is due to the need to incorporate molecules into the photochemical processes, which also absorb in the short-wave region of the visible spectrum. In this case, receptors that absorb in the red region of the spectrum, receive an additional portion of energy due to the effect of phototransformation of shortwave radiation into the

longwave wavelength, which we observed in the tissues of the organism of animals and humans and which was described by us earlier [28].

The second significant change in the previous model of the device was the inclusion of the magnetic field of permanent magnets as an additional physical factor that has a therapeutic effect on the human central nervous system. At the same time, the bone tissues do not prevent the penetration of the magnetic field into the brain tissue, which increases the degree of influence of this factor in the transcranial effect on the patient's brain.

Externally, the photon block of the new device is almost the same as its predecessor. The base of the block, still, has the shape of a helmet, but is made of a more wear-resistant material. In addition, currently the photon block has three base sizes ("S", "M", "L").

The radiation zones of the photon block of the new apparatus are also divided into central 1, frontal-temporal (right and left) 2 and cervico-occipital (right and left) 3 and are shown in Fig. 1. LEDs emitting in different spectral ranges are combined in series into chains. The chains of LEDs uniformly fill each radiation zone so that the distance between adjacent LEDs is in the range of 18–25 mm. The maximums of the emission

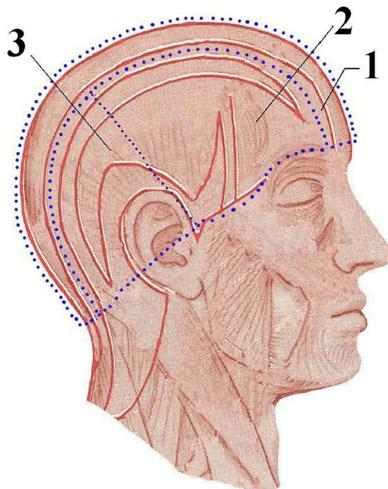

Fig. 1. Schematic division into zones of the photon block of the «Barva-CNS» device and the corresponding biologically active zones

bands of the LEDs used in the «Barva-CNS» devices correspond to the following wavelengths: 940 nm (infrared radiation), 630 nm (red radiation), 525 nm (green radiation), 470 nm (blue radiation) and 405 nm (violet radiation). The emission bandwidth of each LED is 25–30 nm in terms of half-intensity radiation. The radiation power of each LED is in the range of 2–5 mW. The number of LEDs varies from 215 pieces (size "S") to 285 pieces (size "L").

Each radiation zone has an independent power supply channel connected to the switch. The switch allows you to connect the power to the radiation zones

in any combination (from one to all at the same time), depending on the problem being solved. The power supply and control unit «Barva MPB-5S/800» was developed and manufactured by the Laboratory of Physical and Biomedical Electronics of the National Technical University «Kharkiv Polytechnic Institute» according to the technical specifications of the Scientific and Production Medical-Biological Corporation «Laser and Health». In the new model of the device is provided its power from the battery (for example, Power Bank).

Photon-magnetic matrices A. Korobov-V. Korobov «Barva-Laryngologist/FM»

The use of the «Barva-CNS/FM» photon-magnetic apparatus for transcranial photobiomodulation of brain pathologies is a necessary, but not always sufficient condition for achieving a good result. As already mentioned in the introduction, in the event of a lesion in deep areas of the brain, the blood entering these parts of the brain should be photomodified. To solve this problem, the photon-magnetic matrix of A. Korobov-V. Korobov «Barva-Laryngologist/FM» is included in the composition of the phototherapeutic hardware complex. The simplest and most convenient way to photomodify blood entering the brain is transcutaneous irradiation in the carotid arteries.

To achieve this goal, the base of the matrix «Barva-Laryngologist/FM» is structurally made of a flexible material in the form of a rectangular strip with a size of 530×70 mm (adapted for optimal irradiation of the human neck). On the basis of installed 84 LEDs (14 groups of 6 LEDs in the group). Each group of LEDs is connected in series in a chain. The LEDs are equidistant at a distance of 18 mm from each other. Permanent magnets with special holders are mounted on LEDs. Technical parameters and characteristics of LEDs and magnets are the same as in the device «Barva-CNS/PH».

The photon-magnetic matrices of A. Korobov-V. Korobov «Barva-Laryngologist/FM» (Fig. 2) are powered either from a battery (for example, Power Bank) or from an adapter that converts a network alternating current of 220 V, 50 Hz to a direct current of 14 V.

In Fig. 3 shows a photo of the «Barva-CNS/FM» apparatus and the «Barva-Laryngologist/FM» matrix mounted on a mannequin in the working position.



Fig. 2. Photon-magnetic matrix A. Korobov-V. Korobov «Barva-Laryngologist/FM»

The “Laser and Health” Corporation of the “Barva-Laryngologist/FM” matrix produces three standard sizes: 480 × 70 mm (“S”), 530 × 70 mm (“M”) and 580 × 70 mm (“L”).

Flexible photon-magnetic matrices A. Korobov-V. Korobov “Barva-Flex/24FM”

One of the most versatile personal medical devices for light therapy, developed by us and produced by Laser and Health Corporation, are the flexible photon-magnetic matrices of A. Korobov-V. Korobov “Barva-Flex/24FM” the design of which is described in detail in [29]. The inclusion of these matrices in the composition of the phototherapeutic hardware complex for the treatment and prevention of diseases of the brain is due to their ability to have a normalizing effect on the immune, endocrine, central and peripheral nervous systems. Such tactics of treatment, prevention and rehabilitation gives the fastest and most stable result.



Fig. 3. Apparatus Korobov-Posokhov “Barva-CNS/FM” and matrix A. Korobov-V. Korobov “Barva-Laryngologist/FM”

A distinctive feature of photon matrices is that they have a flexible base. This allows the matrices to repeat the shape of that part of the human body to which they are applied, which ensures the most efficient transmission of LED radiation without reflecting losses at the air-skin interface.

The basic version of the matrix, shown schematically in Fig. 4, 5 contains 24 LEDs, located equidistantly in 4 rows of 6 LEDs in each row. Special matrices have an arrangement of 3 × 8 and 2 × 12 LEDs (to illuminate the spine and paravertebral zones).

The photon matrix “Barva-Flex” is a plate 1 with two lugs 2 and 3, designed for attaching elastic belts that allow fixing the matrix on the patient’s body. The matrix is made of hypoallergenic medical rubber and does not cause irritation of the skin. The power supply of the LEDs 4 is supplied from the power source using a cable 5 with a connector 6 (Fig. 4).

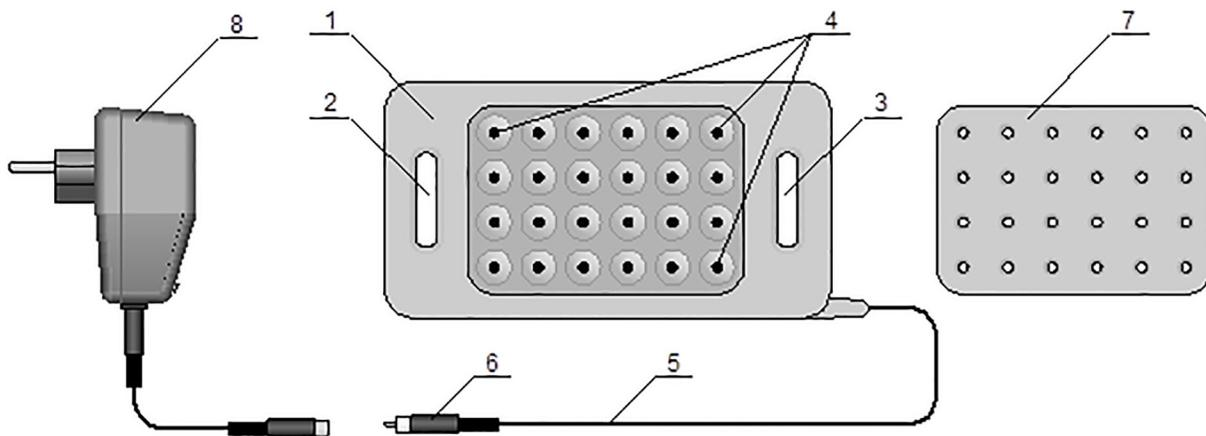

Fig. 4. Schemes of the photon and magnetic matrices “Barva-Flex/24FM”



Fig. 5. Photon matrices A. Korobov-V. Korobov “Barva-Flex/24FM”

If necessary, the combined effect of electromagnetic radiation in the infrared and visible parts of the spectrum with a constant magnetic field on the photon matrix is set the magnetic matrix “Barva-Flex/Mag” 7 (Fig. 4).

The main technical data of the photon matrix “Barva-Flex” and the magnetic matrix “Barva-Flex/Mag” are given in Table 1.

The observance of sanitary and hygienic requirements is ensured through the use of disposable transparent plastic bags for food of appropriate sizes, which

from a specially designed two-channel microprocessor pulse control unit “Barva MPB-2S/80”.

The pulsed control unit “Barva MPB-2S/80” ensures the operation of photon matrices in continuous, pulsed or scanning modes (scanning is performed according to the modulation frequency of the luminous flux). The control unit contains a timer that provides the dosing of exposure for the duration of exposure. Two flexible photon-magnetic matrices can be connected to the control unit at the same time.

When the control unit operates in continuous

Table 1

Technical data of the photon and magnetic matrices “Barva-Flex”

Parameter name	Units	Value
The number of LEDs in the photon matrix	pieces	24
Radiation power of each LED	mWt	5
Supply voltage	V	14
Overall dimensions of the basic version of the photon matrix “Barva-Flex”, not more	mm	190×98×15
The number of ring magnets in the magnetic matrix	pieces	24
Magnetic induction of each magnet	mTl	200
Overall dimensions of the magnetic matrix “Barva-Flex/Mag”, not more	mm	120×80×7

are worn on the matrix. In case of contamination, the surface of the matrix can be treated with a solution of washing powder and disinfected with a 70% solution of ethyl alcohol.

The placement of photon matrices in relation to the patient’s body is distant, contact and contact with compression. In the distant mode of irradiation, the matrix is located at some distance from the body, as a result of which 5–10% of light is reflected from its surface. In the case of distant use of matrices, the latter can be hardened in special holders one or several pieces to ensure the possibility of covering large surfaces, for example, extensive burns. With the contact method of irradiation, almost all of the light is absorbed by the tissues of the body, in which it is distributed according to the laws of nonlinear optics due to tissue heterogeneity. In this case, the photon matrix is fixed on the desired part of the patient’s body, either with the help of an elastic tape, or with the help of “Velcro”.

When the tissues are compressed by the photon matrix, the greatest penetration depth is achieved for light of a given wavelength. In addition, due to the compaction of tissues, the degree of radiation divergence decreases, i.e. his dissipation. Compression of tissues is provided either by the patient’s body itself (lie down on the matrix) or by fixing the matrix with pressure bandages.

The flexible photon-magnetic matrices of A. Korobov-V. Korobov “Barva-Flex/24FM” are powered either from a battery (for example, Power Bank) or from an adapter that converts a network alternating current of 220 V, 50 Hz to a direct current of 14 V, or

mode, the radiation from the phototherapeutic device’s LEDs will be continuous, and the radiation power will be maximum. In the pulsed and scanning modes at any modulation frequency, the duty cycle of the output voltage of the control unit will be 2 (the pulse duration is half the period), and the average radiation power of the phototherapy device will be two times less than in continuous mode.

The inclusion of photon-magnetic matrices A. Korobov-V. Korobov “Barva-Flex/FM” into the phototherapy hardware complex for the treatment and prevention of diseases of the central nervous system is due to the high efficiency of their use for many years for the treatment and prevention of cardiovascular diseases, including myocardial infarction and stroke [30]; for the rehabilitation of post-infarction and post-stroke conditions, as well as for the normalization of high or low blood pressure [31,32]. The timely, during the first two hours after a heart attack or stroke, the use of the “Barva-Flex/FM” photon-magnetic matrix increases the likelihood of a favorable outcome of the treatment of these diseases by at least 80%, as the rheological parameters of the blood normalize under the action of light.

In addition, flexible photon-magnetic matrices are used with high efficiency for the treatment and prevention of respiratory diseases [33,34,35], diseases of the gastrointestinal tract [36,37,38], diseases of the musculoskeletal system [39,40,41], infectious diseases [42,43,44] and many others. This implies the expediency of using the “Barva-Flex/FM” flexible photon-magnetic matrices for treating of patients with diseases of the central nervous system in comorbid conditions.

Experience of using the phototherapeutic hardware complex in the treatment of vascular diseases of the cerebrum

Below are the data of practical application of the above-mentioned devices in the Novoushytsky Territorial Center for Social Services (Khmelnitsky region, Ukraine) [45].

Example 1. Patient Svetlana K., born on 1966.

Diagnosis: discirculatory encephalopathy.

Phototherapy: the patient received 14 treatment sessions using the “Barva-CNS/PH” apparatus. Procedures were carried out daily for 15 minutes in fractional doses (5 minutes irradiation, 5 minutes break). The patient noted improvement on the third day after the start of treatment.

Example 2. Patient Lidia K., born on 1936.

Diagnosis: discirculatory disease with hypertension; chronic insufficiency of cerebral circulation II st.

Phototherapy: the patient received 14 daily treatment sessions with the help of the “Barva-CNS/PH” apparatus. The patient notes improved sleep, reduced headache.

Example 3. Patient Antonina G., born on 1952.

Diagnosis: osteochondrosis of the cervical spine with severe pain; chronic insufficiency of cerebral circulation II st.

Phototherapy: the patient received 14 daily treatment sessions using the “Barva-CNS/PH” apparatus and the “Barva-Laryngologist/PH” matrix. The patient notes improvement in general condition, reduction of headache and neck pain.

The results of complex treatment with the involvement of phototherapy devices allow us to conclude that the positive effect of phototherapy in vascular diseases of the brain.

Experience of using phototherapeutic hardware complex for the rehabilitation of post-stroke conditions (Gorodotsky territorial center of social services, Khmelnytsky region, Ukraine) [46,47]

Example 1. Patient Evgenia F., born on 1951, pensioner, invalid of group II 3/3.

Diagnosis: condition after suffering ischemic stroke, hypertensive disease III st., angina pectoris 2 st.

Infractions: headaches, blinking in eyes, dizziness.

The treatment was carried out using the “Barva-CNS/PH” photon-magnetic apparatus Korobov-Posokhov according to a technique developed by the authors of the apparatus (seven daily procedures lasting 10-15 minutes) and the photon-magnetic matrix A. Korobov-V. Korobov “Barva-Laryngologist/FM” (fourteen daily procedures lasting 15-30 minutes).

Treatment result: flicker in the eyes disappeared, dizziness disappeared and headaches decreased.

Example 2. Patient Vladimir P., born on 1954, pensioner.

Diagnosis: condition after suffering a hemorrhagic stroke (July 2017), left-sided hemiparesis, thalamic pain syndrome.

Complaints: sensitivity in the left upper and lower extremities is impaired, the muscle tone of the left upper and lower extremities is reduced, constant, intermittently burning pains in the left extremities and in the left half of the body, in the left half of the face; the patient moves with the help of crutches.

The treatment was carried out for two weeks (daily) with the help of the devices listed above according to the procedures given in the instructions for the devices.

Results: the patient’s condition is satisfactory, reduced severity of pain by 50%, the sensitivity of the left lower and upper extremities has improved, the muscle tone has decreased, the patient moves with the help of a stick.

Example 3. Patient Valery S., born on 1973, unemployed, disabled person of group I.

Diagnosis: sustained effects of ischemic stroke (2016), right hemiparesis, aphasia.

Complaints: lack of free movements of the right upper and lower extremities, sensitivity in the right upper and lower extremities, periodic headaches.

The treatment was carried out with photon matrices “Barva-Flex/FM24”, “Barva-TsNS”, “Barva-Laryngologist” according to the methods given in the instructions for the devices.

The result of the treatment: the patient’s condition is satisfactory, the sensitivity of the lower limbs has improved, the number and duration of headaches has decreased.

Successful treatment of discirculatory encephalopathy with the help of phototherapy complex (case from practice) [48]

Under our supervision there is a patient of 72 years, suffering for many years with coronary artery disease, atherosclerotic cardiosclerosis, grade III hypertension, chronic hepatitis, small-focal pancreatic fibrosis, saline diathesis, diffuse pneumosclerosis. Since June 2012, the patient has been experiencing transient ischemic attacks (TIA) in the vertebro-basilar basin, clinically manifested by headaches, dizziness, nausea and vomiting, aggravated by a change in body position. In the neurological status – symptoms of damage to the brain stem and cerebellum.

In February 2014 (after the next TIA) a spiral computed tomography of the brain was performed. Identified multiple foci in the brain with a diameter of 10 mm, located subcortical, moderate external and internal subatrophic hydrocephalus. Taking into account the fact that neuro-ophthalmologic examination revealed signs of CSF in the form of blurred visual nerve disk boundaries and congestion of the retinal vein veins, the secondary nature of the pathological foci in the brain was not excluded.

The patient, on her own initiative, spent almost 7 to 10 five-minute light therapy sessions for 7 months using a Korobov-Posokhov polychrome photon matrix “Barva-CNS/HR”, which ensured transcranial light effects on the surface layers of the brain. Simultane-

ously with the transcranial light exposure, the patient performed a transcutaneous luminescence of the carotid arteries using radiation from the photon matrix A. Korobov-V. Korobov "Barva-Laryngologist/HRP". The duration of each procedure was 10–15 minutes.

During this time, the general condition of the patient improved progressively. In the neurological status, almost complete regression of pathological neurological symptoms is noted.

In April 2014, MRI in the white matter of the frontal and parietal lobes was determined by multiple foci ranging in size from 3 to 10 mm, hyperintense on T2VI and FLAIR. In addition, a decrease in the mp-signal at T2 GRE from leptomeningeal membranes of the right parietal region and convexital regions of the left cerebellar hemisphere was determined; expansion of the lateral and third ventricles.

In the control neurological examination in October 2014, the presence of microsymptomatology characteristic of dyscirculatory encephalopathy was noted. With SCT and MRI (1.5 T), no focal changes in the brain substance were detected. At the same time, the presence of external-internal subatrophic hydrocephalus is noted. Thus, in dynamics, neuroimaging techniques showed regression of foci in the white matter of the brain.

Conclusions

1. A phototherapy apparatus complex has been developed for the prevention, treatment and rehabilitation of vascular, inflammatory, degenerative, post-traumatic and other brain diseases that are difficult to treat with drugs, including pharmacoresistant pain syndromes. The phototherapeutic hardware complex includes three devices: the modified photon-magnetic apparatus Korobov-Posokhov "Barva-CNS/FM", the photon-magnetic matrices A. Korobov-V. Korobov "Barva-Laryngologist/FM" and flexible photon-magnetic matrices A. Korobov-V. Korobov "Barva-Flex/24FM".

2. The main indications for phototherapy with the help of phototherapeutic hardware complex, in our opinion, can be:

- acute and chronic circulatory disorders of the brain: acute ischemic strokes, transient cerebral circulatory disorders (including in terms of emergency care), cerebral arteriosclerosis, cerebral vascular atherosclerosis, dyscirculatory atherosclerotic and hypertensive encephalopathy; effects of ischemic and hemorrhagic strokes;

- neurodegenerative diseases of the brain: parkinsonism, Alzheimer's disease, Wilson-Konovalov disease, etc.;

- acute traumatic brain injury and its consequences;

- acute and chronic inflammatory diseases of the brain (arachnoiditis, encephalitis, meningoenphalitis);

- headaches of various genesis;

- neuropathy, neuralgia and neuritis of cranial nerves;

- neurosis and neurosis-like states, sleep disorders, jet lag;

- chronic fatigue syndrome;

- diabetic, hypertensive and atherosclerotic angiopathy of the retina;

- osteochondrosis of the upper cervical spine;

- residual effects and consequences of ischemic and hemorrhagic strokes;

- preoperative preparation and postoperative rehabilitation of patients with the consequences of previously transferred neurological and neurosurgical pathology.

3. The presented clinical observations obtained using the developed phototherapeutic hardware complex for the treatment and prevention of diseases of the brain indicate high efficacy and safety of long-term low-intensity phototherapy in patients with dyscirculatory encephalopathy, with suffered ischemic and hemorrhagic strokes, with hypertensive disease.

4. Comprehension of the described observations naturally leads to the conclusion that it is necessary to conduct detailed basic research on the study of the laws and mechanisms of action of low-intensity electromagnetic radiation of different spectral ranges and a constant magnetic field on the regeneration of the nervous tissue of the brain and peripheral nerves.

References

1. Boonswang NAb, Chicchi M, Lukachek A, Curtiss D. A new treatment protocol using photobiomodulation and muscle /bone/ joint recovery techniques having a dramatic effect on a stroke patient's recovery: a new weapon for clinicians. *BMJ Case Reports*. 2012. DOI:10.1136/bcr.08.2011.4689.
2. Sapon NA, Guk AP, Nikiforova AN, et al. Stroke. The realities and needs of providing neurosurgical care in Ukraine. *Ukr. neyrohirurgich. jurnal [Ukr. neurosurg. journal]*. 2013;4:43-8. (in Russian)
3. Samosyuk IZ, Samosyuk NI, Fedorov SN. Transcranial methods of physiotherapy in the medical rehabilitation of post-stroke patients *Praktichna angiologiya. [Practical angiology]*. 2010;5,6(34,35). (in Russian)
4. Lampl Y. Laser treatment for stroke. *Expert Rev Neurotherapy*. 2007;7:961-5.
5. Lampl Y, Ziviv JA, Fisher M. Infrared therapy for ischemic stroke: a new treatment strategy. *Stroke*. 2007;38:1843-9.
6. Hashmi JT, Huang Y, Sharma BZ, Naeser MA, Hamblin MR. Role of Low-Level Laser Therapy in Neurorehabilitation. *PM R. Author manuscript; available in PMC* 2011 Dec 1. *PM R*. 2010 December. 2 (12 Suppl 2): S292–S305. doi:10.1016/j.pmrj.2010.10.013.
7. Alz.org, 2016 Disease Facts and Figures.
8. *Neurology* March 5, 2014 [Epub ahead of print].
9. *Time Magazine* March 5, 2014.
10. Lim L. *The Potential of Treating Alzheimer's disease with Intranasal Light Therapy*. Toronto: Medic Lights Research Inc. 2013.

11. Hennessy M, Hamblin MR. Photobiomodulation and the brain: a new paradigm. *J Opt.* 2017 January;19(1): 013003–doi:10.1088/2040-8986/19/1/013003.
12. Maksimovich IV. Dementia and Cognitive Impairment Reduction after Laser Transcatheter Treatment of Alzheimer's Disease. *World J Neurosci.* 2015; 5.
13. Berman MH, Halper JP, Nichols TW, Jarrett H, Lundy A, Huang JH. Photobiomodulation with Near Infrared Light Helmet in a Pilot, Placebo Controlled Clinical Trial in Dementia Patients Testing Memory and Cognition. *J Neurol Neurosci.* 2017; 8(1): doi:10.21767/2171-6625.1000176.
14. Naeser MA, Zafonte R, Krengel MH, Martin PI, Frazier J, Hamblin MR, Knight JA, Meehan WP 3rd, Baker EH. Significant improvements in cognitive performance post-transcranial, red/near-infrared light-emitting diode treatments in chronic, mild traumatic brain injury: open-protocol study. *J Neurotrauma.* 2014;31:1008–17.
15. Naeser MA, Martins PI, Ho MD, Krengel MH, Bogdanova Y, Knight JA, Yee MK, Zafonte R, Frazier J, Hamblin MR, Koo BB. Transcranial, red/nearinfrared light-emitting diode therapy to improve cognition in chronic traumatic brain injury. *Photomed Laser Surg.* 2016;34(12):610–26.
16. Wu Q, Huang Y-Y, Dhital S, et al. Low level laser therapy for traumatic brain injury. *SPIE Proc.* 2010;7552:755206–8.
17. Maksimenko VA. Tipovyye narusheniya perifericheskogo krovoobrascheniya i mikrotsirkulyatsii. Uchebnoe posobie [Typical disorders of peripheral circulation and microcirculation. Study guide]. Blagoveschensk; 2013. (in Russian)
18. Litvitskiy PF. Patofiziologiya: ucheb. dlya vuzov [Pathophysiology: studies. for universities]. 4th ed., Moscow: GEOTAR-Media Publ; 2007. 496 p. (in Russian)
19. Maslova MG, Chertok VM, editors. Nizkoenergeticheskie lazery v eksperimente i klinike [Low-energy lasers in experiment and clinic]. Vladivostok: Izdatelstvo Dalnevostochnogo. universiteta Publ.; 1990. 248 p. (in Russian)
20. Kozlov VI, Buylin VA, Samoylov NG, Markov II, Skobelkina OK, editors. Osnovyi lazernoy fizio- i refleksoterapii [Basics of laser physio- and reflexotherapy]. Samara-Kiev; 1993. 216 p. (in Russian)
21. Gotovskiy YUV, Vyisheslavtsev AP, Kosareva LB, et al. Tsvetovaya svetoterapiya [Color light therapy]. Moscow: IMEDISA Publ; 2001. 432 p. (in Russian)
22. Konev SV, Volotovskiy ID. . Fotobiologiya [Photobiology]. Minsk: : Izdatelstvo BGU im. V.I.Lenina Publ; 1979. 383 p. (in Russian)
23. Vladimirov YuA, Osipov AN, Klebanov GI. Photobiological basis of therapeutic use of laser irradiation. *Biohimiya [Biochemistry].* 2004;69(1):103–13. (in Russian)
24. Kaminskiy AV. The use of laser radiation as a stimulating factor of proliferative processes in bone grafting defects. In: . Materialy XXIII Mejdunarodnoy nauchno-prakticheskoy konferentsii. Primenenie lazerov v meditsine i biologii [Proceedings of the XXIII International Scientific and Practical Conference. The use of lasers in medicine and biology]; 2005 May 25–28; Nikolaev. Kharkov: NPMBK "Laser and Health" Publ; 2005, p. 31–32. (in Russian)
25. Tondiy LD, Korobov AM. The use of the Korobov photon matrix "Barva-Flex / K" to stimulate physiological measures to protect the body. In: Materialy XVI Mejdunarodnoy nauchno-prakticheskoy konferentsii. Primenenie lazerov v meditsine i biologii [Materials of the XVI International Scientific and Practical Conference. The use of lasers in medicine and biology]; 2001 Sept 25–28; Theodosius. Kharkov: NPMBK Laser and Health Publ; 2001, p. 28-29. (in Russian)
26. Posohov NF, Kozyr EV, Korobov AM, Chernenkov VG, Serbinenko IA. The Korobov-Posokhov apparatus for phototherapy of diseases of the central nervous system "Barva-CNS". *Fotobiologiya i Fotomeditsina [Photobiology and Photomedicine].* 2007;5(3,4):109-15. (in Russian)
27. Ulaschik VS, editor et al. Minsk: : Belaruskaya navuka Publ; 2015. 379 p. (in Russian)
28. Korobov AM. About photoluminescence of biological objects under the action of low-intensity electromagnetic radiation of the visible spectrum. In: Materialy XXXXI Mejdunarodnoy nauchno-prakticheskoy konferentsii. Primeneniya lazerov v meditsine i biologii [Proceedings of the XXXXI International Scientific Practical Conference. The use of lasers in medicine and biology]; 2014 May 28-31; Kharkiv. Kharkiv: NPMBK Laser and Health Publ; p. 8-11. (in Russian)
29. Korobov AM, Korobov VA. Photon-magnetic matrices Korobov A. - Korobov V. "Barva-Flex/FM24". *Fotobiologiya i Fotomeditsina [Photobiology and Photomedicine].* 2012;9(1,2):132-42. (in Russian)
30. Grigorova IA, Eskin AR, Nekrasova NA. The rationale for the use of the matrix "Barva-Flex" in patients with dyscirculatory encephalopathy. In: Materialy XXV Mejdunarodnoy nauchno-prakticheskoy konferentsii. Primenenie lazerov v meditsine i biologii [Proceedings of the XXV International Scientific and Practical Conference. The use of lasers in medicine and biology]; 2006 May 24–28; Lutsk. Kharkiv: NPMBK Laser and Health Publ; 2006, p. 20–1. (in Russian)
31. Tondiy LD, Lesnaya TA, Zhuravlev VA, et al. Experience of using the Korobov Barva-Flex photon matrices to normalize blood pressure. In: Materialy XXVI Mejdunarodnoy nauchno-prakticheskoy konferentsii. Primenenie lazerov v meditsine i biologii [Proceedings of the XXVI International Scientific and Practical Conference. The use of lasers in medicine and biology]; 2006 Oct 11–14; Yalta. Kharkov: NPMBK Laser and Health Publ; 2006; p. 37–8. (in Russian)
32. Tondiy LD, Lesnaya TA, Zhuravlev VA, et al. The role of phototherapy in the rehabilitation of post-infarction patients. In: Materialy XXVIII Mejdunarodnoy nauchno-prakticheskoy konferentsii. Primenenie lazerov v meditsine i biologii [Proceedings of the XXVIII International Scientific and Practical Conference. The use of lasers in medicine and biology]; 2007 October 21–24; Yalta. Kharkov: NPMBK Laser and Health Publ; 2007, p. 53–5. (in Russian)
33. Gorbunova EM, Zasimskaya VA. Application of phototherapy methods in the complex sanatorium-resort treatment of patients with chronic obstructive pulmonary diseases. In: Materialy XXX Mejdunarodnoy nauchno-prakticheskoy konferentsii. Primenenie lazerov v meditsine i biologii [Proceedings of the XXX International Scientific and Practical Conference. The use of lasers in medicine and biology]; 2008 Oct 8–11; Yalta. Kharkov: NPMBK Laser and Health Publ; 2008, p. 165–6. (in Russian)
34. Poteyko PI, Korobov AM, Korobov VA. The effectiveness of magnetic laser therapy in patients with pulmonary tuberculosis according to acupuncture diagnostics. In: Materialy XXVII Mejdunarodnoy nauchno-prakticheskoy

- konferentsii. Primenenie lazerov v meditsine i biologii [Proceedings of the XXVII International Scientific and Practical Conference. The use of lasers in medicine and biology]; 2007 Apr 18–21; Kharkov. Kharkov: NPMBK Laser and Health Publ; 2007. p. 53–4. (in Russian)
35. Gradil GI, Kozko VN, Chorna TT, Merkulova NF, Mogilenets EI. Study of non-monochromatic infrared and visible radiation effectiveness in the complex treatment of community-acquired pneumonia in infectious disease hospital. In: Materialy XXXVII Mejdunarodnoy nauchno-prakticheskoy konferentsii. Primenenie lazerov v meditsine i biologii [Proceedings of the XXXVII International Scientific Practical Conference. The use of lasers in medicine and biology]; 2012 Aug 24–29; Helsinki. Kharkov: VN Karazin KhNU Publ; 2012, p. 11. (in Russian)
36. Ashurov ShE, Baybekov IM. Morphological substantiation of the choice of types and methods of phototherapy in the complex treatment and prevention of perforation of gastroduodenal ulcers. In: Materialy XXXXI Mejdunarodnoy nauchno-prakticheskoy konferentsii. Primenenie lazerov v meditsine i biologii [Proceedings of the XXXXI International Scientific Practical Conference. The use of lasers in medicine and biology]; 2014 May 28–31; Kharkov. Kharkov: VN Karazin KhNU Publ; 2014, p. 54–5. (in Russian)
37. Baybekov IM, Kabulov MK, Butaev AKh. The possibilities of using phototherapy in the treatment of the main complications of peptic ulcer disease (morphological aspects). In: Materialy XXXXI Mejdunarodnoy nauchno-prakticheskoy konferentsii. Primenenie lazerov v meditsine i biologii [Proceedings of the XXXXI International Scientific and Practical Conference. The Use of Lasers in Medicine and Biology]; 2014 May 28–31; Kharkov. Kharkov: VN Karazin KhNU Publ, 2014, p. 55–6. (in Russian)
38. Scherbatska OO. Effectiveness of the Korobov photon matrix Korobov Barva-Flex/ JIK with corrective power systems. In: Materialy XXVIII Mejdunarodnoy nauchno-prakticheskoy konferentsii. Primenenie lazerov v meditsine i biologii [Proceedings of the XXVIII International Scientific and Practical Conference. Use of Lasers in Medicine and Biology]; 2007 Oct 21–24; Yalta. Kharkov: NPMBK Laser and Health Publ; 2007; p. 42–3. (in Russian)
39. Baklikov OL, Zabelin VG, Chernyaev AL. Laser therapy of spinal osteochondrosis, accompanied by spondylolisthesis with severe pain syndrome. In: Materialy XXV Mejdunarodnoy nauchno-prakticheskoy konferentsii. Primenenie lazerov v meditsine i biologii [Proceedings of the XXV International Scientific and Practical Conference. Application of lasers in medicine and biology]; 2006 May 24–28; Lutsk. Kharkiv: NPMBK Laser and Health Publ; 2006; p. 10. (in Russian)
40. Zhuravleva LV, Fedorov VA, Alexandrova NK. Application of phototherapy in patients with articular syndrome. In: Materialy XXXVIII Mejdunarodnoy nauchno-prakticheskoy konferentsii. Primenenie lazerov v meditsine i biologii [Proceedings of the XXXVIII International Scientific and Practical Conference. The Use of Lasers in Medicine and Biology]; 2012 Oct 3–6; Yalta. Kharkov: VN Karazin KhNU Publ; 2012; p. 30–1. (in Russian)
41. Tondiy LD, Kas IV, Tondiy OL. The use of photon matrices Korobov “Barva-Flex” in the treatment of chronic pain syndrome in patients with vertebral osteochondrosis. In: Materialy XXI Mejdunarodnoy nauchno-prakticheskoy konferentsii. Primenenie lazerov v meditsine i biologii [Proceedings of the XXI International Scientific and Practical Conference. Application of lasers in medicine and biology]; 2004 May 26–29; Odessa. Kharkov: NPMBK Laser and Health Publ; 2004; p. 62–3. (in Russian)
42. Zhigarev YuA. Laser therapy of encephalitis of herpetic etiology. In: Materialy XVII Mejdunarodnoy nauchno-prakticheskoy konferentsii. Primenenie lazerov v meditsine i biologii [Proceedings of the XVII International Scientific and Practical Conference. Application of lasers in medicine and biology]; 2002 May 21–23; Kharkov. Kharkov: NPMBK Laser and Health Publ; 2002; p. 32–3. (in Russian)
43. Zhigarev YuO. Prospects for low-intensity laser imaging in the complex neuroinfection. In: Materialy XXV Mejdunarodnoy nauchno-prakticheskoy konferentsii. Primenenie lazerov v meditsine i biologii [Proceedings of the XXV International Scientific and Practical Conference. Application of lasers in medicine and biology]; 2006 May 24–28; Lutsk. Kharkov: NPMBK Laser and Health Publ; 2006; p. 28–30. (in Russian)
44. Muliar OS. Prevention of acute respiratory viral infection in the minds of the child sanatorium using light. In: Materialy yubileynoy XX Mejdunarodnoy nauchno-prakticheskoy konferentsii. Primenenie lazerov v meditsine i biologii [Proceedings of the jubilee XX International Scientific and Practical Conference. Application of lasers in medicine and biology]; 2003 Oct 8–11; Yalta. Kharkov: NPMBC Laser and Health Publ; 2003; p. 53. (in Ukrainian)
45. Kovbasyuk DV, Chepela NV, Danilchuk AO, Prisyazhnyuk NV. Experience of using photon matrices in the complex treatment of vascular diseases of the brain. In: Materials XLIX International Scientific and Practical Conference. Application of lasers in medicine and biology and 2nd Gamaleia’s Readings; 2018 Oct 3–7; Hajduszoboszlo. Kharkov: Petrov Publ; 2018; p. 122–4. (in Ukrainian)
46. Filipovska DI, Neduraieva IV, Kosman VA, Shevchenko NI. Experience of light treatment of cerebral circulatory disorders in the conditions of the territorial social service center. In: Materialy XLVIII Mejdunarodnoy nauchno-prakticheskoy konferentsii. Zastosuvannya lazeriv v meditsine i biologii [Materials XLVIII International Scientific and Practical Conference. Application of lasers in medicine and biology]; 2018 May 24–25; Kharkiv. Kharkiv: Petrov Publ; 2018; p. 98–100. (in Ukrainian)
47. Zakutiy MM, Marchuk TA, Filipovska DI. Improving the technology of light therapy of the cerebral blood circulation disorders in the conditions of the territorial social service center. In: Materials XLIX International Scientific and Practical Conference. Application of lasers in medicine and biology and 2nd Gamaleia’s Readings; 2018 Oct 3–7; Hajduszoboszlo. Kharkiv: Petrov Publ; 2018, p. 24–6. (in Ukrainian)
48. Posokhov NF, Korobov AM, Makarov VN, Vorobyev VV, Kostyukovskaya AE, Nazarchuk AG, et al. Successful treatment of dyscirculatory encephalopathy using the Korobov-Posokhov photon matrix Barva-CNS/PH (case study). In: Materialy XLII Mijnarodnoi naukovoprakticheskoy konferentsii. Zastosuvannya lazeriv u meditsini ta biologii [Materials XLII International Scientific and Practical Conference. Application of lasers in medicine and biology]; 2014 Des 11–13; Yaremche. Kharkiv: Petrov Publ; 2014; p. 43–5. (in Russian)

INSTRUCTION TO AUTHORS

Photobiology and Photomedicine is an international scientific and practical peer-reviewed journal devoted to experimental and theoretical research in the field of clinical photomedicine, photobiology and experimental photomedicine, physical and technical outlines of photobiology and photomedicine.

Articles are published in Ukrainian, Russian or English.

Material of the article is submitted to the editors office to a USB flash drives or e-mail, in the following structure:

- the text of the article;
- illustrations of articles with separate graphic files;
- high-quality portrait photographs of authors (**photos inserted in Word are not accepted!**).

The text of the article should be typed in 11 pt, Times New Roman, with a single line spacing. Margins on the pages: top and bottom – 2 cm; left – 3 cm; right – 2 cm.

Required structural elements of the article:

1. UDC
2. Title of article
3. Information about the authors: initials and surname, academic degree, academic rank, position, work-place (organization name, address), contact number, e-mail address, ORCID
4. Annotation and keywords
5. The main text of the article
6. References

Requirements to the text of the article

The title of article should be short, informative and reflect the content of the work.

The annotation should have a volume of 1,000–1,200 phonetic symbols. It is based on the type of abstracts in abstract journals and reflects the essence of experiments, the main results and their interpretation. The abstract should not contain ballast words, introductory phrases and non-informative expressions.

The section “**Introduction**” should contain a statement of the problem in its general form and its connection with important scientific or practical tasks; a brief analysis of recent research and publications in which the solution to this problem was initiated, the identification of specific outstanding issues to which this article is devoted, and the formulation of the purpose of the work. In other words, the introduction should answer the question: what is known in this area; what remains unknown; what is the task of this work.

The section “**Methodology**” should contain information about objects of the research, experimental conditions, analytical methods, devices and reagents. This section also provides information about retries of experiments, methods of statistical analysis of results.

In the section “**Results**” it is necessary to describe the detected effects. The presentation of the results should reflect common factors that follow from the received data.

The purpose of the section “**Discussion**” is the generalization and interpretation of the results, the analysis of cause-effect relationships between the detected effects. The obtained information should be compared with the available literature and show its novelty. The discussion should conclude with the answer to the question posed in the introduction.

References (list of reference links) and designation of quotations in the text are made in Vancouver style. The designation of quotations in the text is given in square brackets in Arabic numerals; consecutive numbering is used (in the order of mention in the text). If the surname of the author of the quoted work is indicated in a paraphrase or a quotation inside the line, the designation of quotation is placed immediately after the last name. If the author's surname is not specified in the text, then designation of quotation is put at the end of the quoted text after the punctuation marks. If the source is mentioned in the text again, it should be assigned the same number. When quoting several sources at the same time, it is necessary to list each number in brackets, with a comma or dash without gap.

Example: ... navigation controlled laser interstitial thermal therapy method. [11,16,18-20]

The bibliographic description of the list of reference links

If the publication contains from *one to six authors*, the reference should list them all with a comma. If authors are *more than six*, it is necessary to list six authors with a comma and to note “et. al.” The reference should reduce the number of pages, where possible, for example, if the quotation is placed on pages 123-126, then the reference is 123-6. If the publication has a DOI, then it should be specified after the URL. It is necessary to reduce the names of the months in the dates of the treatment/publication, etc. The names of the journals should be decreased.

In English-language articles where the list of references is given in English, a bibliographic description of non-English sources (Russian, Ukrainian, etc.) is made up of the following rules:

- the surnames and initials of the authors are transliterated;
- title of the article (section of the book): translation into English in square brackets;
- name of the journal (book): transliterated name, then translated into English in square brackets;
- the city of publication of the book: translation into English; name of publishing house: transliteration with the addition of acronym Publ.
- at the end of the bibliographic description, the source language is indicated in parentheses.

Detailed instruction for filling out the references can be found on the journal's website:

www.fnfjournal.univer.kharkov.ua.

Examples of references

1) Article from the journal: Petitti DB, Crooks VC, Buckwalter JG, Chiu V. Blood pressure levels before dementia. *Arch Neurol*. 2005 Jan 12;62(1):112-6.

Немец АЮ, Ваврив ДМ. Взаимодействие высокочастотных и низкочастотных колебаний в синхронизируемом генераторе. *Известия высших учебных заведений. Радиоэлектроника*. 2015 Янв 8;58(12):53-61.

2) Book: Carlson BM. *Human embryology and developmental biology*. 4th ed. St. Louis: Mosby; 2009. 541 p.

3) Materials of conferences: Grassby AJ. Health care in the multi-cultural society. In: Walpole R, editor. *Rural Health. Proceedings of the Rural Health Conference of the Royal Australian College of General Practitioners*; 1978; Melbourne. Melbourne, AU: The Royal Australian College of Practitioners; 1979. p. 49-50.

4) Patent: Pagedas AC, inventor; Ancel Surgical R&D Inc., assignee. Flexible endoscopic grasping and cutting device and positioning tool assembly. United States patent 20020103498. 2002 Aug 1.

5) Article from the Russian-language journal. Sigal VL, Bidnenko VN. [Mechanism of destruction of tumor tissue with local hyperthermia]. *Vestnik novyih meditsinskih tehnologiy* [Herald of new medical technologies]. 2000;7(4):105-6. (in Russian)

Structural elements

Formulas and symbols mentioned in the text of the article should be typed in the formula editor Math Type Equation. Each formula should be a separate object, the font of all formulas is equal. Numbering of formulas is mandatory – in parentheses, from the right side of the text borders.

All illustrations and tables should have a title (for pictures – bottom, for the tables – top), they should be placed in appropriate places in the text of the article and be in sequence numbered.

Pictures are provided additionally with separate graphic files: drawings, diagrams, schemes, etc. submitted in **eps**, **ai** or **cdr** formats; photographs are submitted in **tiff** or **jpg** formats with a resolution of at least 300 dpi, with image sizes ranging from 80 mm to 170 mm wide.

Terms and designation of technical parameters should be used in accordance with the norms of the State Standard, and measurement units – in the international system of units (SI).

Editorial preparation of the article

An article that is supplied to the editorial office, is registered and sent to a scientific reviewer who signs the article for publication. If there are comments, the article is returned to the authors for revision.

The corrected version should be returned by the author to the editorial office together with the answer to the comments.

The editorial office reserves the right to correct and reduce the manuscript, as well as to return to the authors works that do not correspond to the journal's profile and requirements of the editorial office.

ІНСТРУКЦІЯ ДЛЯ АВТОРІВ

Фотобіологія та Фотомедицина — це міжнародний науково-практичний рецензований журнал, присвячений експериментальним та теоретичним дослідженням в області клінічної фотомедицини, фотобіології та експериментальної фотомедицини, фізико-технічних основ фотобіології та фотомедицини.

Статті публікуються українською, російською або англійською мовами.

Матеріал статті до редакції подається на USB-флеш-накопичувачах або електронною поштою, у наступному складі:

- текст статті;
- ілюстрації статті окремими графічними файлами;
- якісні портретні фотографії авторів (**фотографії, вставлені в Word, не приймаються!**).

Текст статті має бути набраний шрифтом 11 pt, Times New Roman, з одинарним міжрядковим інтервалом. Поля на сторінках: верхнє і нижнє — 2 см; ліве — 3 см; праве — 2 см.

Обов'язкові структурні елементи статті:

1. УДК
2. Заголовок статті
3. Відомості про авторів: ініціали та прізвище, науковий ступінь, вчене звання, посада, місце роботи (назва організації, адреса), контактний телефон, адреса електронної пошти, ORCID
4. Анотація та ключові слова
5. Основний текст статті
6. Посилання

Вимоги до тексту статті

Назва статті має бути короткою, інформативною і відображати зміст роботи.

Анотація повинна мати обсяг 1000–1200 фонетичних знаків. Вона будується на кшталт рефератів в реферативних журналах і відображає суть експериментів, основні результати та їх інтерпретацію. Анотація не повинна містити баластні слова, вступні фрази і неінформативні вирази.

Розділ **«Вступ»** повинен містити постановку проблеми в загальному вигляді та її зв'язок із важливими науковими чи практичними завданнями; короткий аналіз останніх досліджень і публікацій, в яких започатковано розв'язання даної проблеми, виділення конкретних невирішених питань, яким присвячується означена стаття, формулювання мети роботи. Іншими словами, вступ повинен відповідати на питання: що відомо в даній області; що залишається невідомим; яка задача даної роботи.

Розділ **«Методика»** повинен містити відомості про об'єкти дослідження, умови експериментів, аналітичні методи, прилади та реактиви. У цьому ж розділі подаються відомості про повторення експериментів, методи статистичного аналізу результатів.

У розділі **«Результати»** необхідно описати виявлені ефекти. Виклад результатів повинен відображати закономірності, які випливають з отриманих даних.

Завданням розділу **«Обговорення»** є узагальнення та інтерпретація результатів, аналіз причинно-наслідкових зв'язків між виявленими ефектами. Отриману інформацію необхідно порівняти з наявними літературними даними і показати її новизну. Обговорення повинно завершуватися відповіддю на питання, поставлене у вступі.

Посилання (список використаних джерел) та позначення цитування в тексті слід оформлювати за Ванкуверським стилем. Позначення цитування в тексті подається у квадратних дужках арабськими цифрами; застосовується наскрізне нумерування (у порядку згадування в тексті). Якщо прізвище автора цитованої праці вказано в парафразі чи цитаті всередині рядка, позначення цитування ставиться одразу після прізвища. Якщо ж прізвище автора не вказано в тексті, то позначення цитування ставиться наприкінці цитованого тексту після розділових знаків. Якщо джерело згадується у тексті знову, йому необхідно присвоїти той самий номер. При цитуванні кількох джерел одночасно, необхідно перерахувати кожен номер у дужках, через кому або тире без пробілів.

Приклад: ... navigation controlled laser interstitial thermal therapy method. [11,16,18-20]

Правила бібліографічного опису для списку посилань

Якщо в публікації зазначено *від одного до шести авторів*, у посиланні необхідно перерахувати їх усіх через кому. Якщо *авторів більше шести*, необхідно перерахувати шістьох авторів через кому та вказати «та ін.». У посиланні необхідно скорочувати число сторінок, де це можливо, наприклад, якщо цитату розміщено на сторінках 123-126, то в посиланні вказується 123-6. Якщо в публікації є DOI, то його необхідно вказати після URL. Необхідно скорочувати назви місяців у датах звернення/публікації тощо. Назви журналів необхідно зазначати скорочено.

В англomовних статтях, де список посилань (References) подається англійською мовою, бібліографічний опис неанглomовних джерел (рос., укр. та ін.) складається за такими правилами:

- прізвища та ініціали авторів транслітеруються;
- назва статті (розділу книги): переклад англійською мовою у квадратних дужках;
- назва журналу (книги): транслітерована назва, потім переклад англійською мовою у квадратних дужках;
- місце видання книги: переклад англійською мовою; назва видавництва: транслітерація з додаванням скорочення Publ.
- у кінці бібліографічного опису в круглих дужках вказується мова джерела.

З детальнішою інструкцією щодо оформлення посилань можна ознайомитись на сайті журналу: www.fnfjournal.univer.kharkov.ua.

Приклади посилань

1) Стаття з журналу: Petitti DB, Crooks VC, Buckwalter JG, Chiu V. Blood pressure levels before dementia. Arch Neurol. 2005 Jan 12;62(1):112-6.

Немец АЮ, Ваврив ДМ. Взаимодействие высокочастотных и низкочастотных колебаний в синхронизируемом генераторе. Известия высших учебных заведений. Радиоэлектроника. 2015 Янв 8;58(12):53-61.

2) Книга: Carlson BM. Human embryology and developmental biology. 4th ed. St. Louis: Mosby; 2009. 541 p.

3) Матеріали конференцій: Grassby AJ. Health care in the multi-cultural society. In: Walpole R, editor. Rural Health. Proceedings of the Rural Health Conference of the Royal Australian College of General Practitioners; 1978; Melbourne. Melbourne, AU: The Royal Australian College of Practitioners; 1979. p. 49-50.

4) Патент: Глухов ОЗ, Хархота ГІ, Агурова ІВ, Прохорова СІ, винахідники; Донецький ботанічний сад НАН України, патентовласник. Спосіб використання галофітів для демінералізації едафотопів техногенних земель. Патент України № 83384. 2013 Вер 10.

5) Стаття з російськомовного журналу: Sigal VL, Bidnenko VN. [Mechanism of destruction of tumor tissue with local hyperthermia]. Vestnik novyih meditsinskih tehnologiy [Herald of new medical technologies]. 2000;7(4):105-6. (in Russian)

Структурні елементи

Формули та символи, що згадуються в тексті статті, повинні бути набрані в редакторі формул Math Type Equation. Кожна формула повинна бути окремим об'єктом, шрифт всіх формул одноманітний. Обов'язкова нумерація формул — у круглих дужках, з правого краю границь тексту.

Всі ілюстрації і таблиці повинні мати назви (для рисунків — знизу, для таблиць — зверху), вони повинні розташовуватися у відповідних місцях тексту статті і бути послідовно пронумеровані.

Рисунки подаються додатково окремими графічними файлами: креслення, діаграми, схеми і т. п. подаються в **eps**, **ai** чи **cdr** форматах; фотографії подаються в **tiff** чи **jpg** форматах з роздільною здатністю не менше ніж 300 dpi, розміром зображення від 80 мм до 170 мм завширшки.

Терміни і позначення технічних параметрів слід вживати відповідно до норм Держстандарту, а одиниці вимірювання — в міжнародній системі одиниць (СИ).

Редакційна підготовка статті

Стаття, яка надходить до редакції, реєструється і направляється науковому рецензенту, який підписує статтю до друку. При наявності зауважень статтю повертають авторам на доопрацювання.

Виправлений варіант автор повинен повернути до редакції разом з відповіддю на зауваження.

Редакція залишає за собою право виправляти та скорочувати рукопис, а також повертати авторам роботи, які не відповідають профілю журналу і вимогам редакції.

ИНСТРУКЦИЯ ДЛЯ АВТОРОВ

Фотобиология и Фотомедицина — это международный научно-практический рецензируемый журнал, посвященный экспериментальным и теоретическим исследованиям в области клинической фотомедицины, фотобиологии и экспериментальной фотомедицины, физико-технических основ фотобиологии и фотомедицины.

Статьи публикуются на украинском, русском или английском языках.

Материал статьи в редакцию подается на USB-флэш-накопителях или электронной почтой, в следующем составе:

- текст статьи;
- иллюстрации статьи отдельными графическими файлами;
- качественные портретные фотографии авторов (**фотографии, вставленные в Word, не принимаются!**).

Текст статьи должен быть набран шрифтом 11 pt, Times New Roman, с одинарным междустрочным интервалом. Поля на страницах: верхнее и нижнее — 2 см; левое — 3 см; правое — 2 см.

Обязательные структурные элементы статьи:

1. УДК
2. Заголовок статьи
3. Сведения об авторах: инициалы и фамилия, ученая степень, ученое звание, должность, место работы (название организации, адрес), контактный телефон, адрес электронной почты, ORCID;
4. Аннотация и ключевые слова
5. Основной текст статьи
6. Литература

Требования к тексту статьи

Название статьи должно быть кратким, информативным и отражать содержание работы.

Аннотация должна иметь объем 1000–1200 фонетических знаков. Она строится по типу рефератов в реферативных журналах и отражает суть экспериментов, основные результаты и их интерпретацию. Аннотация не должна содержать балластные слова, вводные фразы и неинформативные выражения.

Раздел **«Введение»** должен содержать постановку проблемы в общем виде и ее связь с важными научными и практическими задачами; краткий анализ последних исследований и публикаций, в которых начато решение данной проблемы, выделение конкретных нерешенных вопросов, которым посвящена статья, формулировку цели работы. Иными словами, вступление должно отвечать на вопросы: что известно в данной области; что остается неизвестным; какая задача данной работы.

Раздел **«Методика»** должен содержать сведения об объектах исследования, условия экспериментов, аналитические методы, приборы и реактивы. В этом же разделе приводятся сведения о повторении экспериментов, методы статистического анализа результатов.

В разделе **«Результаты»** необходимо описать выявленные эффекты. Изложение результатов должно отражать закономерности, вытекающие из полученных данных.

Задачей раздела **«Обсуждение»** является обобщение и интерпретация результатов, анализ причинно-следственных связей между выявленными эффектами. Полученную информацию необходимо сравнить с имеющимися литературными данными и показать ее новизну. Обсуждение должно завершаться ответом на вопрос, поставленный во введении.

Литература (список использованных источников) и обозначения цитирования в тексте следует оформлять по Ванкуверскому стилю. Обозначение цитирования в тексте подается в квадратных скобках арабскими цифрами; применяется сквозная нумерация (в порядке упоминания в тексте). Если фамилия автора цитируемой работы указано в парафразе или цитате внутри строки, обозначение цитирования ставится сразу после фамилии. Если же фамилия автора не указана в тексте, то обозначение цитирования ставится в конце цитируемого текста после знаков препинания. Если источник упоминается в тексте снова, ему необходимо присвоить тот же номер. При цитировании нескольких источников одновременно, необходимо перечислить каждый номер в скобках, через запятую или тире без пробелов.

Пример: ... navigation controlled laser interstitial thermal therapy method. [11,16,18-20]

Правила библиографического описания для списка литературы

Если в публикации указано *от одного до шести авторов*, в ссылке необходимо перечислить их всех через запятую. Если *авторов более шести*, необходимо перечислить шесть авторов через запятую и указать «и др.». В ссылке необходимо сокращать число страниц, где это возможно, например, если цитату размещено на страницах 123-126, то в ссылке указывается 123-6. Если в публикации есть DOI, то

его необходимо указать после URL. Необходимо сокращать названия месяцев в датах обращения / публикации т. п. Названия журналов необходимо указывать сокращенно.

В англоязычных статьях, где список ссылок (References) подается на английском языке, библиографическое описание неанглоязычных источников (рус., укр. и др.) составляется по следующим правилам:

- фамилии и инициалы авторов транслитерируются;
- название статьи (главы книги): перевод на английский язык в квадратных скобках;
- название журнала (книги): транслитерированное название, затем перевод на английский язык в квадратных скобках;
- место издания книги: перевод на английский язык; название издательства: транслитерация с добавлением сокращения Publ.
- в конце библиографического описания в круглых скобках указывается язык источника.

С подробной инструкцией по оформлению ссылок можно ознакомиться на сайте журнала: www.fnjournal.univer.kharkov.ua.

Примеры ссылок

1) Статья из журнала: Petitti DB, Crooks VC, Buckwalter JG, Chiu V. Blood pressure levels before dementia. Arch Neurol. 2005 Jan 12;62(1):112-6.

Немец АЮ, Ваврив ДМ. Взаимодействие высокочастотных и низкочастотных колебаний в синхронизируемом генераторе. Известия высших учебных заведений. Радиоэлектроника. 2015 Янв 8;58(12):53-61.

2) Книга: Carlson BM. Human embryology and developmental biology. 4th ed. St. Louis: Mosby; 2009. 541 p.

3) Материалы конференций: Grassby AJ. Health care in the multi-cultural society. In: Walpole R, editor. Rural Health. Proceedings of the Rural Health Conference of the Royal Australian College of General Practitioners; 1978; Melbourne. Melbourne, AU: The Royal Australian College of Practitioners; 1979. p. 49-50.

4) Патент: Глухов ОЗ, Хархота ГІ, Агурова ІВ, Прохорова СІ, винахідники; Донецький ботанічний сад НАН України, патентовласник. Спосіб використання галофітів для демінералізації едафотопів техногенних земель. Патент України № 83384. 2013 Вер 10.

5) Статья из русскоязычного журнала: Sigal VL, Bidnenko VN. [Mechanism of destruction of tumor tissue with local hyperthermia]. Vestnik novyih meditsinskih tehnologiy [Herald of new medical technologies]. 2000;7(4):105-6. (in Russian)

Структурные элементы

Формулы и символы, упоминаемые в тексте статьи, должны быть набраны в редакторе формул Math Type Equation. Каждая формула должна быть отдельным объектом, шрифт всех формул однообразен. Обязательна нумерация формул — в круглых скобках, с правого края границ текста.

Все иллюстрации и таблицы должны иметь названия (для рисунков — снизу, для таблиц — сверху), они должны располагаться в соответствующих местах текста статьи и быть последовательно пронумерованы.

Рисунки подаются дополнительно отдельными графическими файлами: чертежи, диаграммы, схемы и т. п. подаются в **eps**, **ai** или **cdr** форматах; фотографии подаются в **tiff** или **jpg** форматах с разрешением не менее 300 dpi, размером изображения от 80 мм до 170 мм в ширину.

Термины и обозначения технических параметров следует употреблять в соответствии с нормами Госстандарта, а единицы измерения — в международной системе единиц (СИ).

Редакционная подготовка статьи

Статья, которая поступает в редакцию, регистрируется и направляется научному рецензенту, который подписывает статью в печать. При наличии замечаний статью возвращают авторам на доработку. Исправленный вариант автор должен вернуть в редакцию вместе с ответом на замечания.

Редакция оставляет за собой право исправлять и сокращать рукопись, а также возвращать авторам работы, которые не соответствуют профилю журнала и требованиям редакции.

Наукове видання

Фотобіологія та Фотомедицина

24 '2018

Міжнародний науково-практичний журнал

(Англійською, українською, російською мовами)

Комп'ютерне верстання *О.М. Бойкачова*

Відповідальний за випуск *К.В. Русанов*

Підписано до друку 31.05.2018. Формат 60×84/8. Папір офсетний.

Друк ризографічний.

Ум. друк. арк. 10,01. Обл.-вид. арк. 14,91.

Тираж 100 пр. Зам. № Безкоштовно.

61022, Харків, майдан Свободи, 4
Харківський національний університет імені В.Н. Каразіна
Видавництво

Надруковано: Харківський національний університет імені В.Н. Каразіна
61022, Харків, майдан Свободи, 4, тел. +380-057-705-24-32
Свідоцтво суб'єкта видавничої справи ДК № 3367 від 13.01.09