

UDC 621.384.6.

BEAM DYNAMICS IN OUTPUT CHANNELS FROM RECIRCULATOR SALO**I.S. Guk, S.G. Kononenko, F.A. Peev, A.S. Tarasenko***National Science Centre "Kharkov Institute of Physics and Technology"**Academicheskaja str. 1, Kharkov, Ukraine, 61108**E-mail: guk@kipt.kharkov.ua*

Received 26 November 2012, accepted 24 January 2013

Optimization of recirculator SALO magnetic structure allowed to refine essentially parameters of electron beams in input points of output channels in the basic observational halls. Parameters of a beam along a trajectory of a motion and on an exit of the basic channels are given. Calculations are spent taking into account non-linear fields of dipole and quadrupole recirculator magnets.

KEY WORDS: electron, recirculator, dipole magnet, quadrupole lens, SALO.

ДИНАМІКА ПУЧКА В КАНАЛАХ ВИВОДА ИЗ РЕЦИРКУЛЯТОРА SALO**И.С. Гук, С.Г. Кононенко, Ф.А. Пеев, А.С. Тарасенко***Национальный научный центр «Харьковский физико-технический институт»**ул. Академическая 1, 61108, Харьков, Украина*

Оптимизация магнитной структуры рециркулятора SALO позволила существенно улучшить параметры пучка электронов в точках выпуска частиц в основные экспериментальные залы. В работе приведены параметры пучка вдоль траектории движения и на выходе основных каналов вывода пучка из рециркулятора. Расчёты проведены с учетом нелинейных составляющих полей дипольных и квадрупольных магнитов рециркулятора.

КЛЮЧЕВЫЕ СЛОВА: электрон, рециркулятор, дипольный магнит, квадруполь, SALO.

ДИНАМІКА ПУЧКА В КАНАЛАХ ВИВОДУ З РЕЦИРКУЛЯТОРА SALO**І.С. Гук, С.Г. Кононенко, Ф.А. Пеев, О.С. Тарасенко***ННЦ «Харківський фізико-технічний інститут» НАН України**вул. Академічна 1, 61108, м. Харків, Україна*

Оптимізація магнітооптичної структури рециркулятора SALO дозволила суттєво поліпшити параметри пучка електронів в точках виводу часток в основні експериментальні зали. В роботі приведені параметри пучка вздовж траєкторії руху і на виході основних каналів виводу пучка з рециркулятора. Розрахунки проведені з урахуванням впливу нелінійних компонентів магнітного поля дипольних і квадрупольних магнітів рециркулятора.

КЛЮЧОВІ СЛОВА: електрон, рециркулятор, дипольний магніт, квадруполь, SALO.

Project recirculator SALO, developed in KIPT, provides the withdrawal of the electron beam in several experimental areas [1, 2]. Of greatest interest is the consideration of the motion of particles in the channels intended for nuclear physics research [2, 3], as the requirements for the beam on these channels, the strongest. Characteristic of the beams on these channels will be fairly frequent change of the electron energy, which in turn may require adjustment of the position and size of the beam on the target. Prediction of the behaviour of beams in the channels is also important for the development of the equipment needed for physical research [4]. The work main task is research of the electron beams movement along the basic channels and research possibilities of management by these beams on an exit of channels.

As shown in [5, 6], the parameters of the beam in the recirculator can have a significant impact nonlinear components of dipole and quadrupole magnets. Beam transport channels contain a sufficiently large number of dipoles and quadrupoles. Therefore the characteristics of the beam can be changed on these channels under the influence of the same factors. Study of the motion of the particles was performed using the program MAD X [7], by tracking particles through a magnetic system of channels. The structure of the magnetic systems of beam channels [3, 8] is the dipole magnets of the first recycling ring and the dipole magnets and quadrupoles of the second recirculator ring [2, 6]. The values of sextupole field component of the dipole magnets of the first ring recycling were taken from [9]. In this publication, they were measured on the prototype magnets to be used in the recirculator SALO. Dipole magnets of the second ring recycling and transportation channels are not produced. Because they are like armor, naturally assume that sextupole field component of these magnets will not exceed the values measured for the magnets to the first ring. [9] Octupole component value of the quadrupole lenses was calculated based on data from the literature [10]. These data have been used in numerical simulations of particle dynamics in the channels. Sextupole component is taken into account in the description of the dipole. Octupole component were simulated thin lens on the entrance and exit of the quadrupole. The drawings are in the distribution used in the simulation of motion 3000 particles through magnetic channel structure.

Magneto-optical systems all considered channels are consistent with achromatic requirement. Parameters for all of the magnetic elements have been optimized to meet the specified requirements.

CHANNELS A, B, C

In the channels A, B and C can be derived a beam with an energy of 60 to 750 MeV [1-3, 6]. For beam forming on channels A and B (see Fig. 1) is used first recycling ring dipole magnet 12M1, four quadrupoles A2J1-A2J4 and four dipole magnets A3M1-A3M3, B3M1. Beam passes into the channel C when dipole A3M2 is off. Beam can be directed into the channel A (using a magnet A3M3) or channel B (using a magnet B3M1) when you turn on the magnet. In the area between the dipole magnets A2M1 and A3M2 beam moves in the concrete protection thickness of 6 meters, between the target hall where you want to place a recirculator, and Hall SP-103 spectrometer, where the supposed location of the main units using a maximum energy of 730 MeV.

Beam with an energy of 270 MeV (a single passage of the accelerating structure) can be displayed in these rooms with the magnetic system of the injection tract and magnets that are part of the magnetic system of channels [6]. To produce a beam with an energy of up to 490 MeV is necessary to use a magnetic system of the first ring of recycling. For maximum energy used magnetic system of the second ring of recycling. The beam will be three times the accelerating structure. Dynamics of changes in the cross section of the beam from the entrance to the transport channel (before magnet 12M1) to magnet A2M3 in the channel A at the maximum energy of 730 MeV is shown in Fig. 2. The distance is measured from the entrance to the magnet 12M1.

In Fig. 3 in Figure 4 shows the distribution of particles in phase space x, x' and y, y' at the output of channel A on the target at a distance of 23.175 m from the output for the same energy.

Distribution of the particle density at the target at the same point in Fig. 5.

Density distribution of the particles on targets located on channels B and C, will be similar to those described for channel A.

Ports A, B and C are designed for experiments with beams of polarized and non-polarized electrons. Installing a free electron laser is available on the channel C [1, 2].

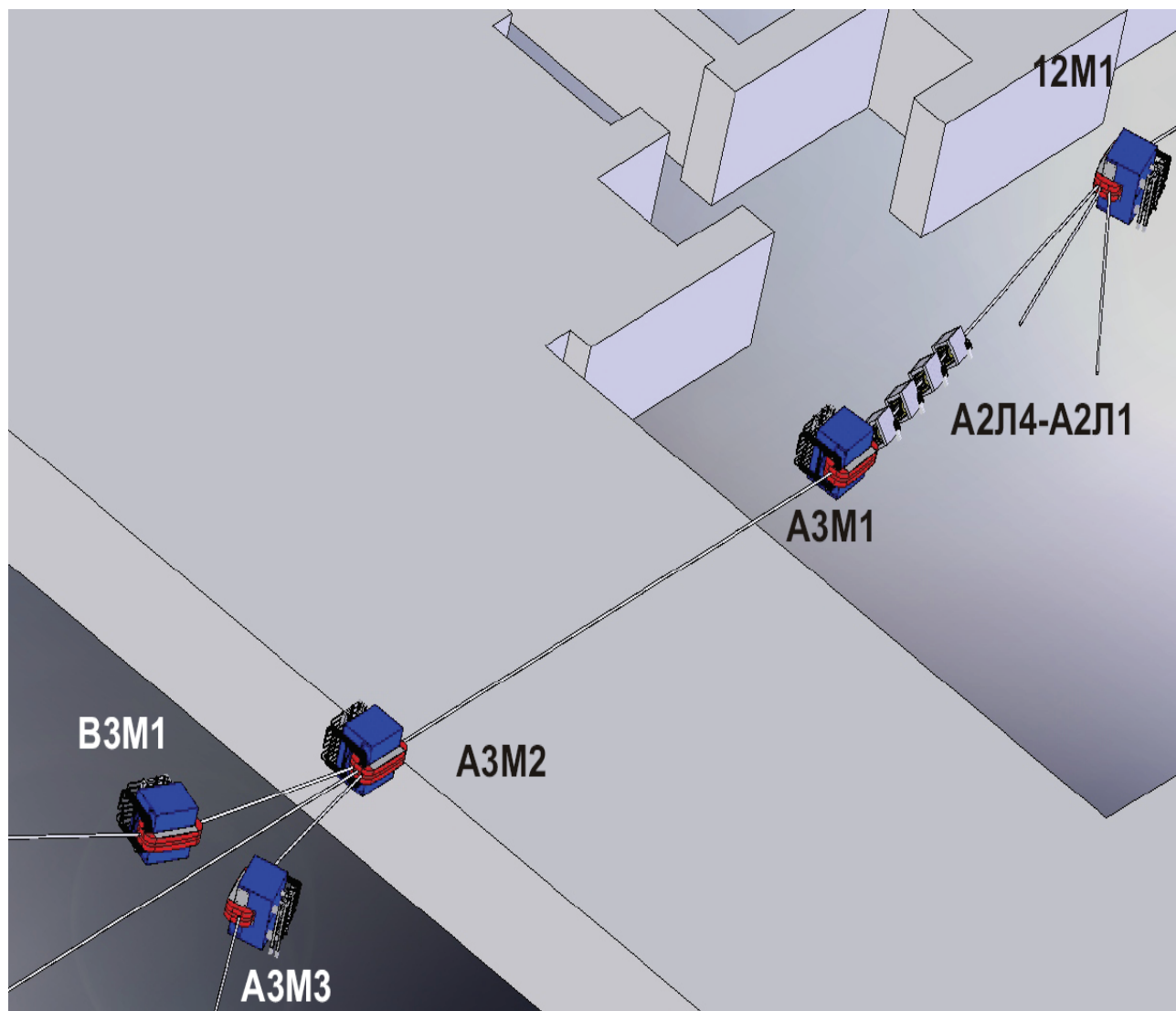

Fig. 1. Arrangement of magnets and quadrupoles on channels A, B, C

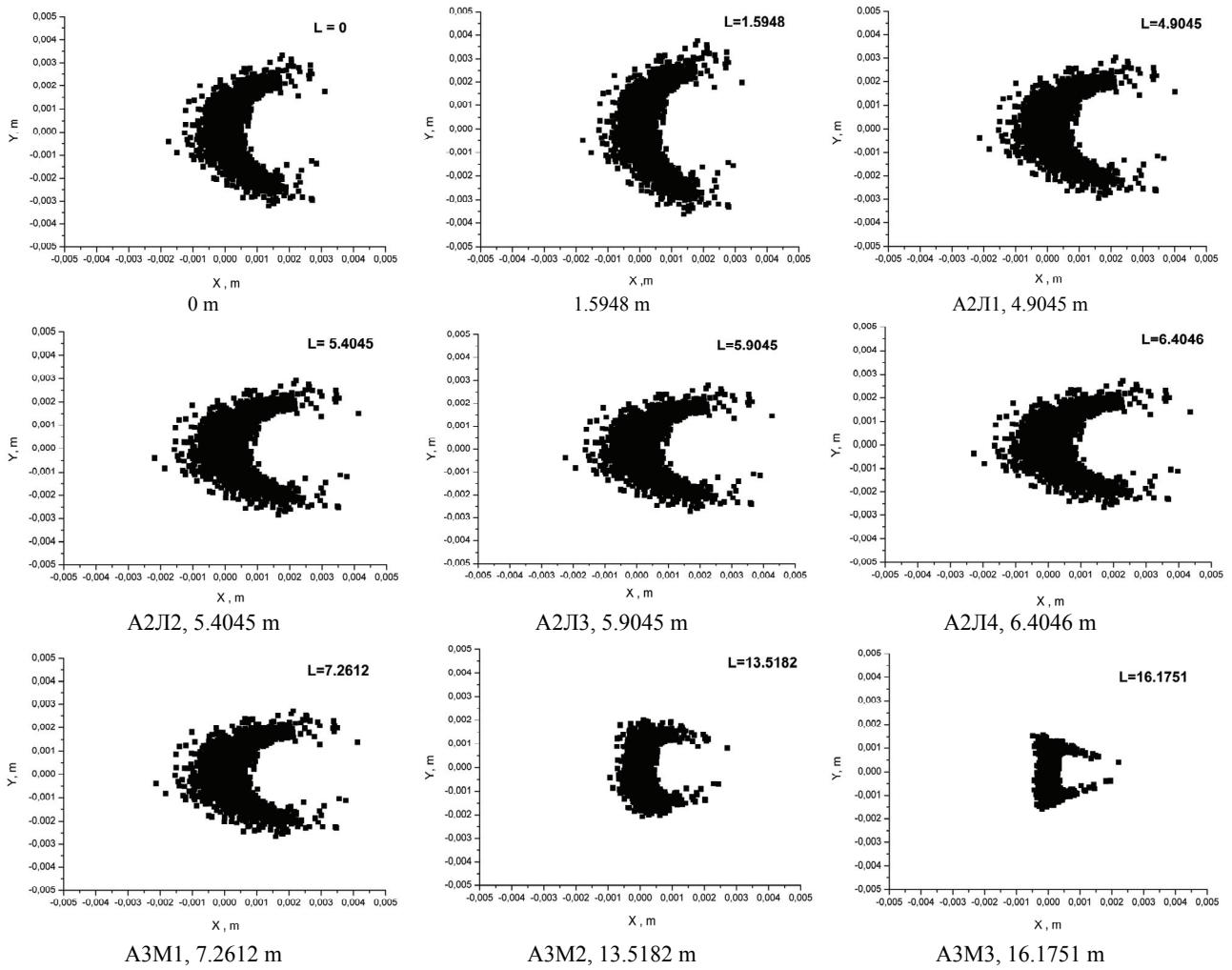

Fig. 2. Electron density distribution in the beam cross section along the trajectory of the channel A

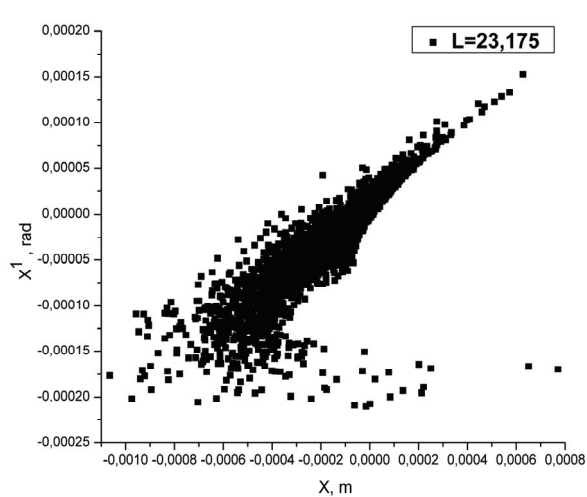

Fig.3. The distribution of particles in the phase space x, x' on target for channel A

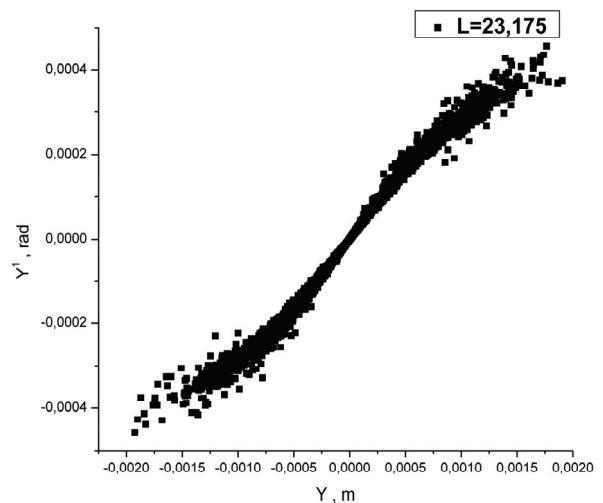

Fig.4. The distribution of particles in the phase space y, y' on target for channel A

The density distribution of the particles in Fig. 5 was obtained by taking into account all the nonlinearities of the magnetic elements channel A, on Fig. 5b off octupole components of quadrupoles, and on Fig. 5c off sextupole components of the dipole magnets. We see that only they affect the distribution of electrons in the beam in this channel.

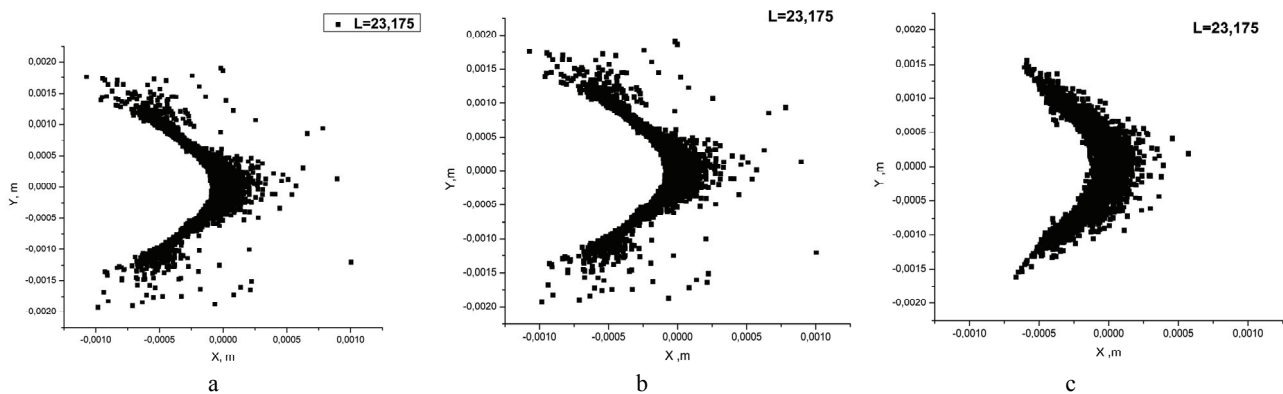

Fig. 5. The distribution of the particle density at the target output channel A
 a - all nonlinearities are include, b - octupole components are switched off, c - all nonlinearities are switched off

CHANNEL D

Electrons with a maximum beam energy of 260 MeV can be output in the D-channel after a single passage through the recirculator accelerating structure. At double the maximum of the beam energy can be increased up to 500 MeV [6]. The dipole magnet of the first recycling ring 12M6, five quadrupole lenses of the second recycling ring - 22J19-22J12 and 23J13, two dipole magnets 23M1D and 23M2D and five quadrupole lenses 23J1D-23J5D (Fig. 6) can be used for output and beam formation at the target on the channel. The design of the 23M1D and 23M2D magnets similar construction of the second recycling ring magnets, and used on the channel quadrupole lenses are similar to the first and second recycling rings lens [2,3,6,8]. Modes of all elements of the magneto-optical channel system selected so as to achieve the system achromatism on output channel MD target at a distance of 59.82 m from the entrance of the magnet 12M6.

D channel to be used for work on the beams of electrons and photons.

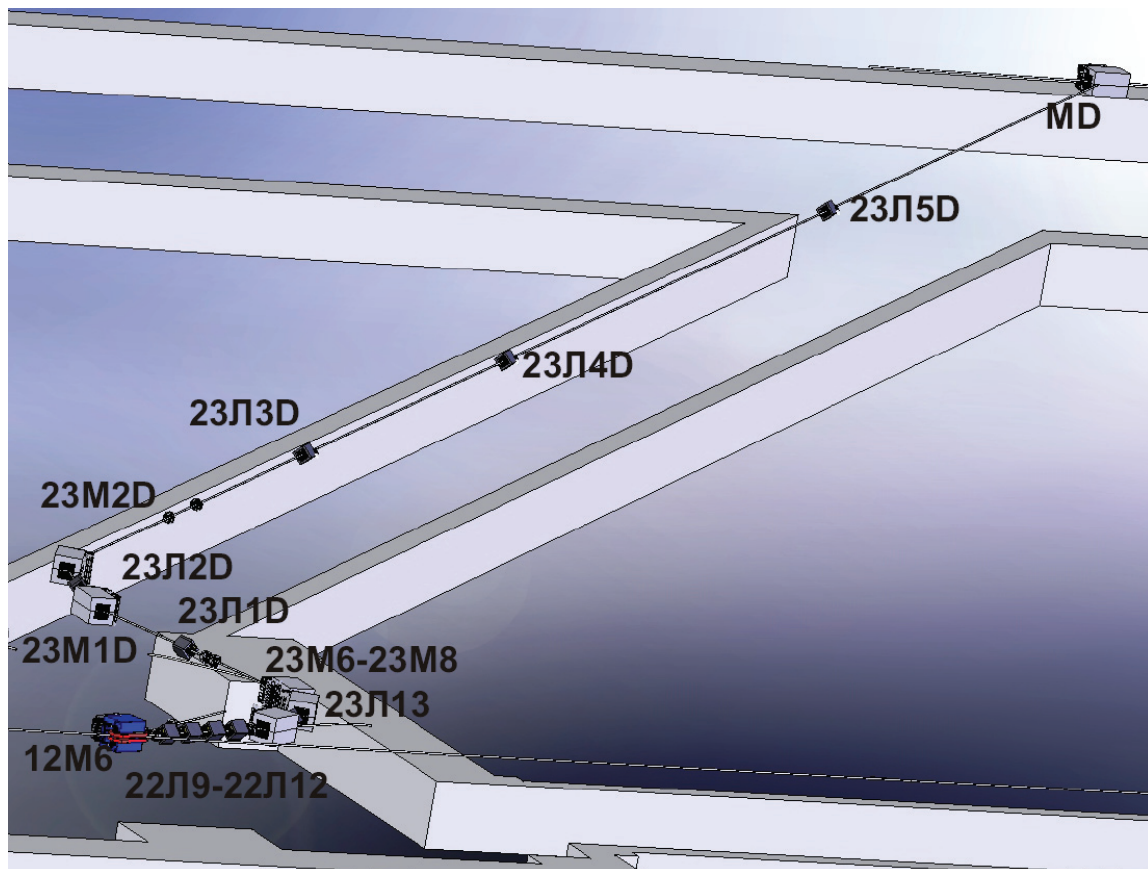

Fig. 6. Arrangement of magnets and quadrupoles on channel D

The dynamics of electron density distribution in the cross section of the beam and the beam size along the transport channel are shown in Fig. 7.

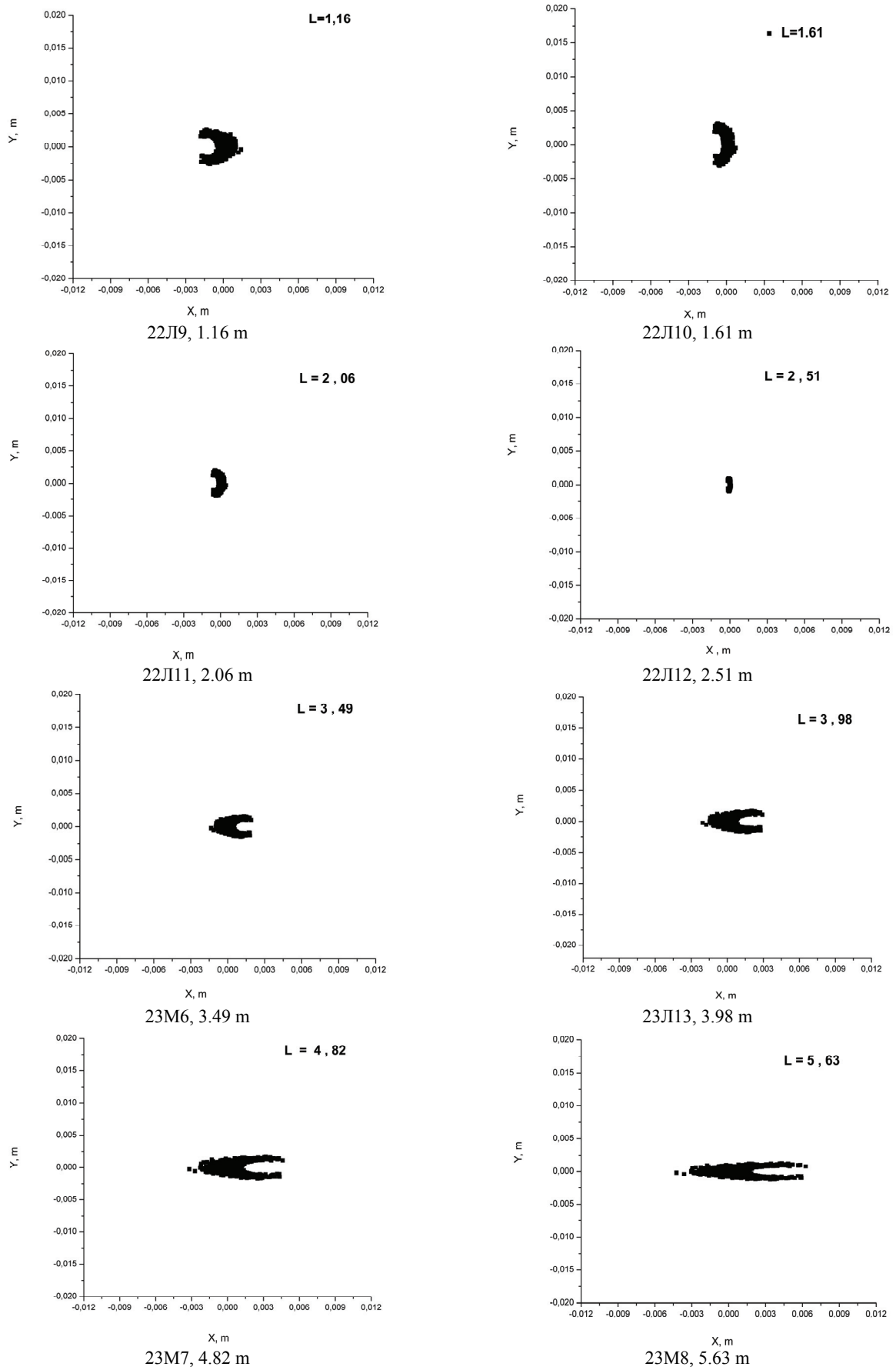

Fig. 7. Electron density distribution in the beam cross section along the trajectory of the channel D

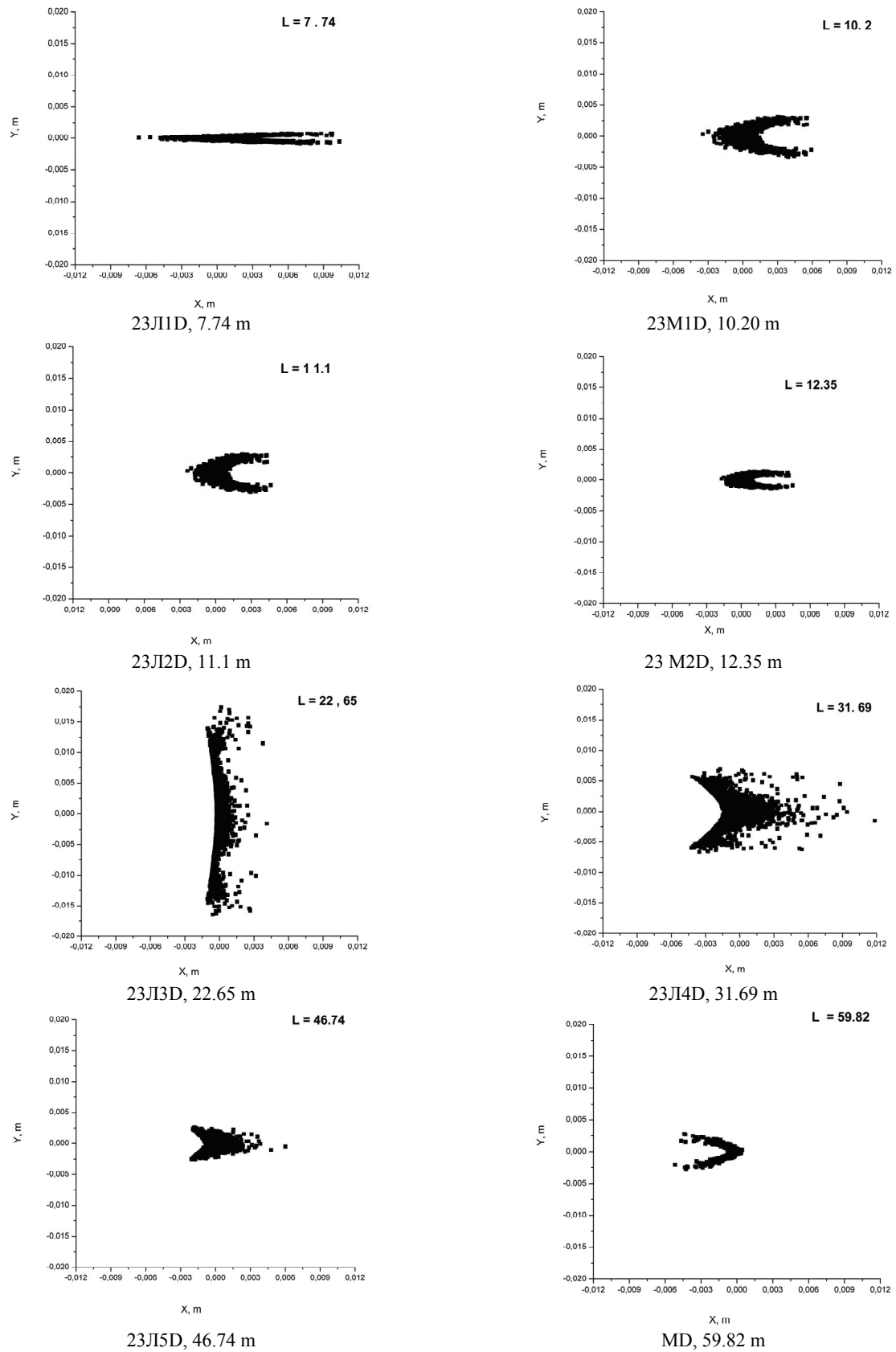

Fig. 7(Continued). Electron density distribution in the beam cross section along the trajectory of the channel D

Shown in Fig. 7 distribution was obtained by optimizing the structure of the magneto-optical recirculator system. The density distribution of the beam in phase space x, x' and y, y' at the entrance to the dipole magnet 12M6 shown in Fig. 8 and Fig. 9. Modeling the movement was carried out for the energy 493 MeV. The density distribution of the particles in the beam cross section at this point is shown in Fig. 10.

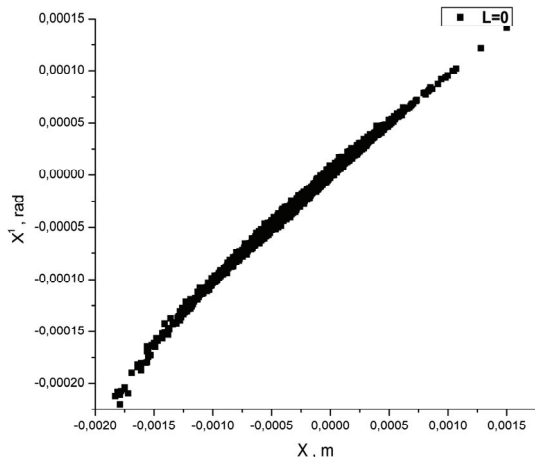

Fig. 8. The distribution of particles in the phase space x, x' at the entrance to the magnet 12M6

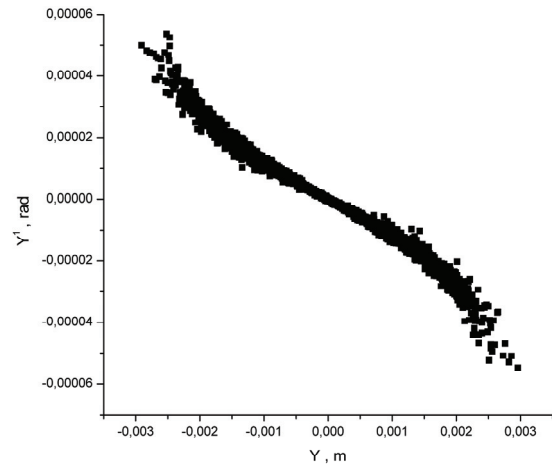

Fig. 9. The distribution of particles in the phase space y, y' at the entrance to the magnet 12M6

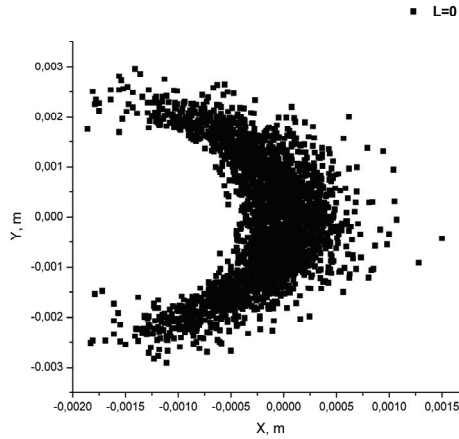

Fig. 10. The density distribution of the electron beam at the entrance to the magnet 12M6

The cross-sections shown in Fig. 7 in the sequence performed at the same scale charts, which gives the opportunity to observe the evolution of the beam, and come to the conclusion that at the selected vertical and horizontal aperture of the magnetic elements of the channel: dipoles, quadrupoles, correctors, beam losses along the path will be negligible.

Influence of nonlinear field components of the dipoles and quadrupoles on channel D on the transverse dimensions of the beam and the density of electrons in the beam at the output of the channel shows Fig. 11. In Fig. 11a shows the results of the tracking of particles with non-linear components of the field, in Fig. 11b octupole components quadrupoles are zero. In Fig. 11c additional sextupole field components of the dipoles are zero also.



Рис. 11. The distribution of the particle density on the target of the D channel output

a - all nonlinearities are include, b - octupole components are switched off, c - all nonlinearities are switched off

Apparently, octupole components of quadrupoles to make minor changes in the density distribution of the beam, while the sextupole components dipoles fivefold increase vertical size and twice the horizontal size.

Dimensions of the beam at the output can be changed by the lens, located at the end of the channel. Since the density distribution of the beam, resulting in tuning achromatic channel mode (see Fig. 12) is transformed into the distribution shown in Fig. 13 when the field gradient in the 23J15D lens alter from -0.0723 to 0.09 T m. Using a larger

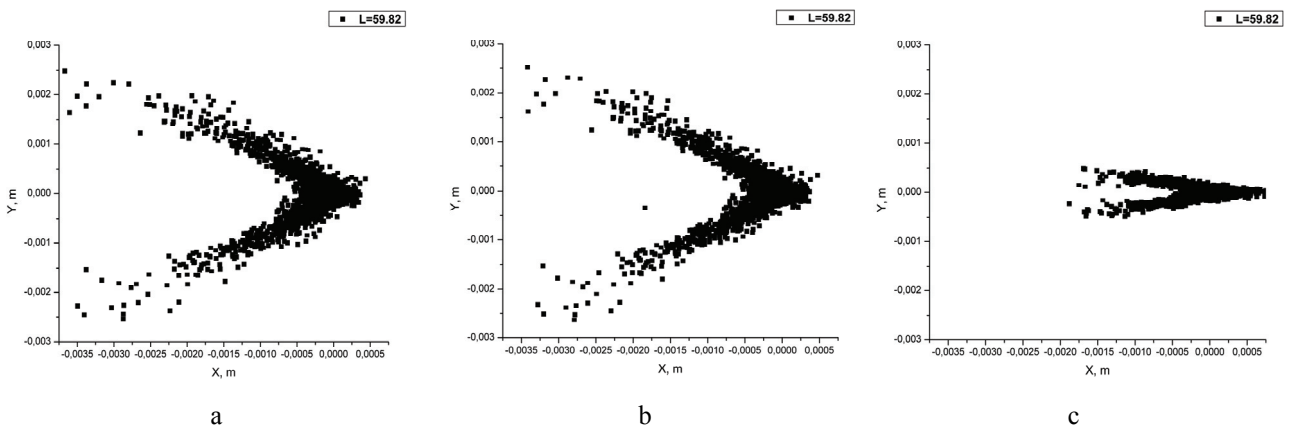
number of lenses allows for more fine-tuning the parameters of the beam on the target.

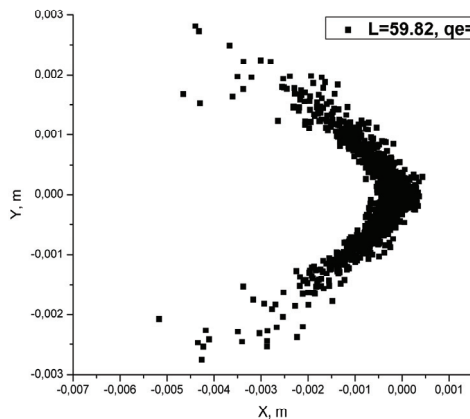

Fig. 12. The density distribution of the electron beam at the output of the channel D the field gradient in the 23J15D lens is -0.0723 T m

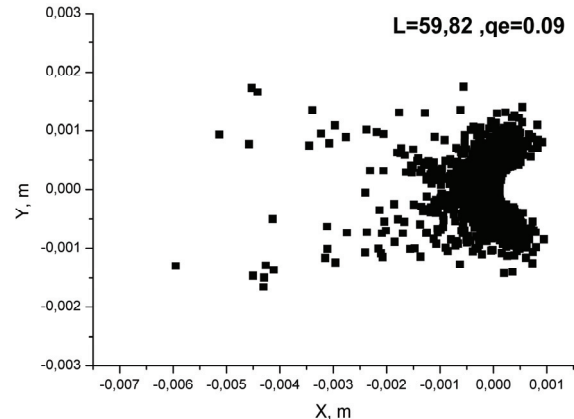

Fig. 13. The density distribution of the electron beam at the output of the channel D the field gradient in the 23J15D lens is equal 0.09 T m

CHANNEL EFEL

EFEL channel suppose to use to work with beams of electrons and photons up to an energy of 500 MeV. General view of the magnetic system EFEL channel is shown in Fig. 14. In a channel beam with an energy of 240 MeV can be derived using the first five magnets of the first recycling ring and magnets are turned off in the second semi-ring [6]. To focus and adjust the position of the beam is necessary to use quadrupoles and correctors, located on the first arch of the first ring - 22J15 – 22J18 and 2K3, 2K4 [6]. Beam with a maximum energy of up to 490 MeV is displayed in the channel when turned off magnets second arch of the second ring of recycling. Beam in this channel can be formed by four quadrupoles 22J19 – 22J12 belonging to the second recycling ring, and four quadrupoles J1E – J4E on the channel, and two dipole magnets 23M1E 23M2E set on the channel (the second ring magnet 23M6 off). Correction of the beam can be achieved correctors following the magnet 12M6 and 22J12 lens. To output beam transmitted accelerating structure only once, with energies up to 240 MeV, the magneto-optical elements can also be used to form the beam after the magnet 12M6. The transverse distribution of particles for energy 493 MeV at the entrance to the canal in front of the magnet 12M6 similar to that shown in Figures 7, 8 and 9.

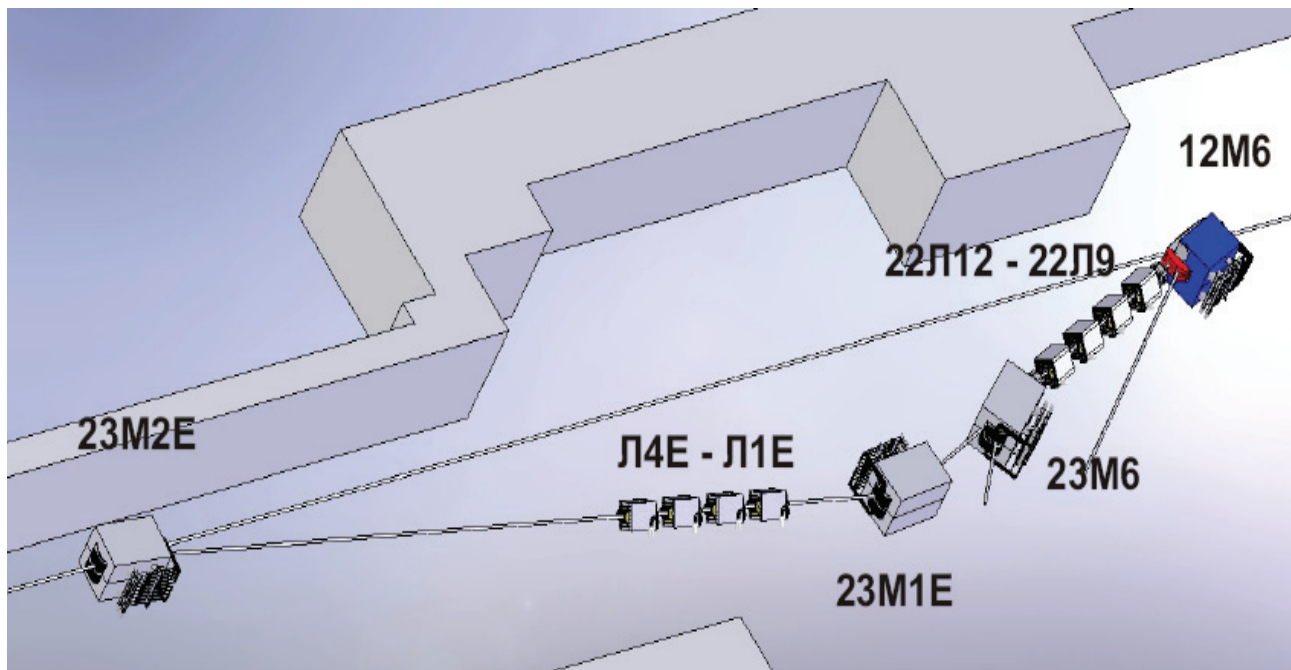

Fig. 14. Arrangement of magnets and quadrupoles on channel EFEL

In Fig. 15a shows the distribution of the particle density at the target MD, calculated on the basis of non-linear components of the dipole and quadrupole magnets. In Fig. 15b and Fig. 15c - when you turn off octupole field components quadrupoles and sextupole components of the dipole magnets, respectively.

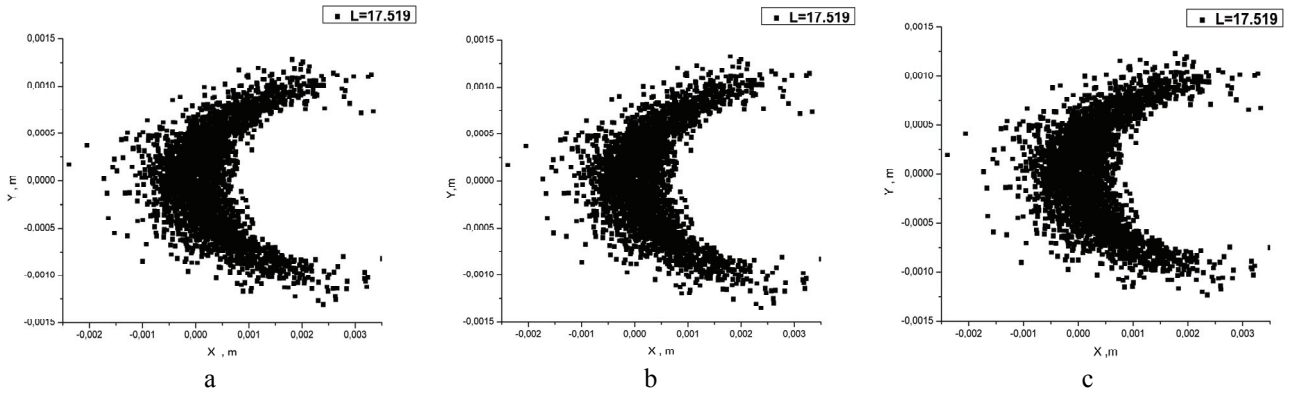

Fig. 15. The distribution of the particle density on the target of the EFEL channel output
 a - all nonlinearities are include, b - octupole components are switched off, c - all nonlinearities are switched off

It can be seen that, as the channel D, the main influence on the size of the beam on the target MD, located at a distance of 17.519 meters from the entrance to the magnet 12M6, has sextupole component of the dipole magnets used for beam forming in the channel, however, in contrast to the D, changing the size of the beam is small.

The cross section of the beam along the channel for the energy 493 MeV is shown in Fig. 16.

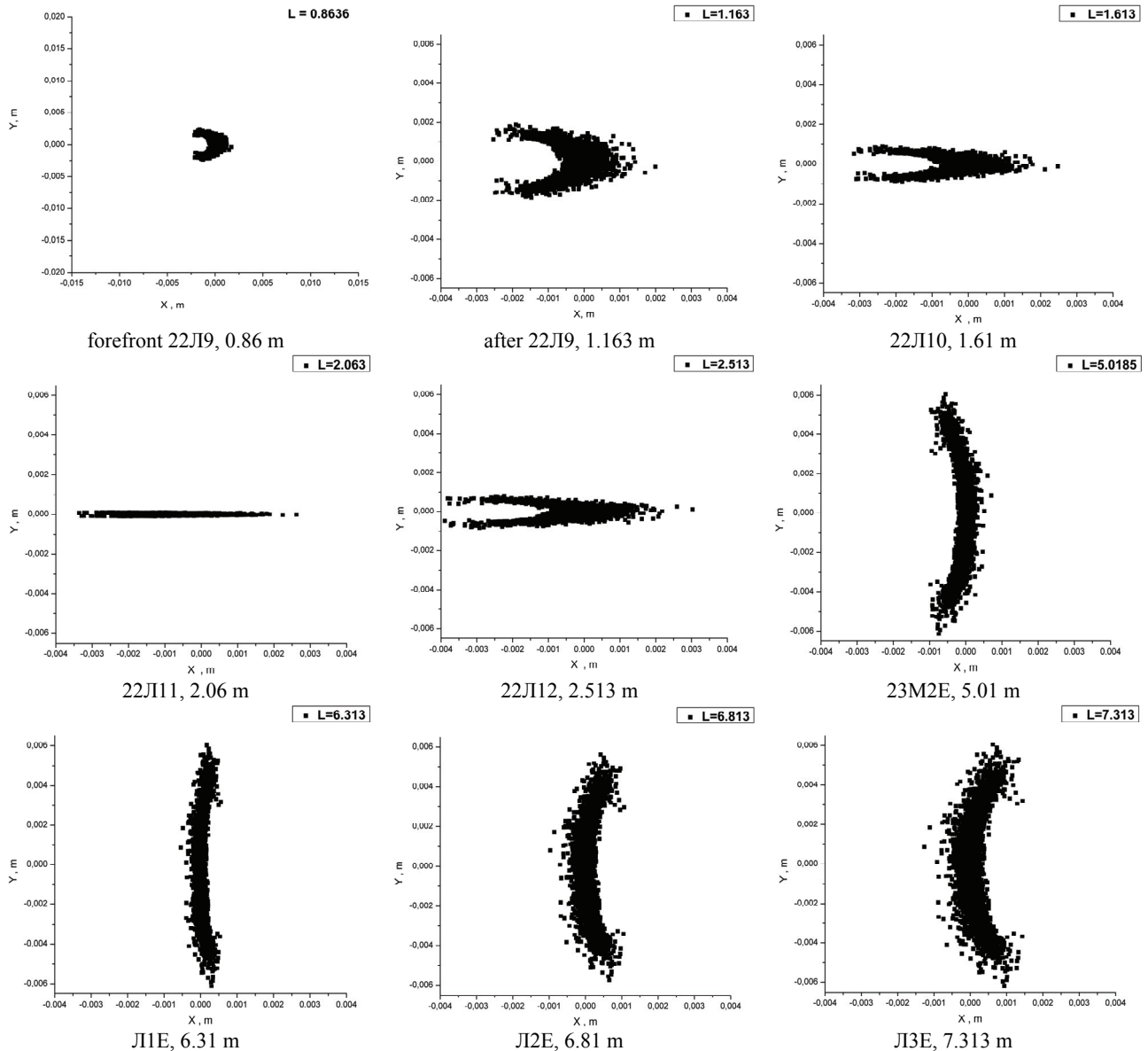

Fig. 16. Electron density distribution in the beam cross section along the trajectory of the EFEL channel

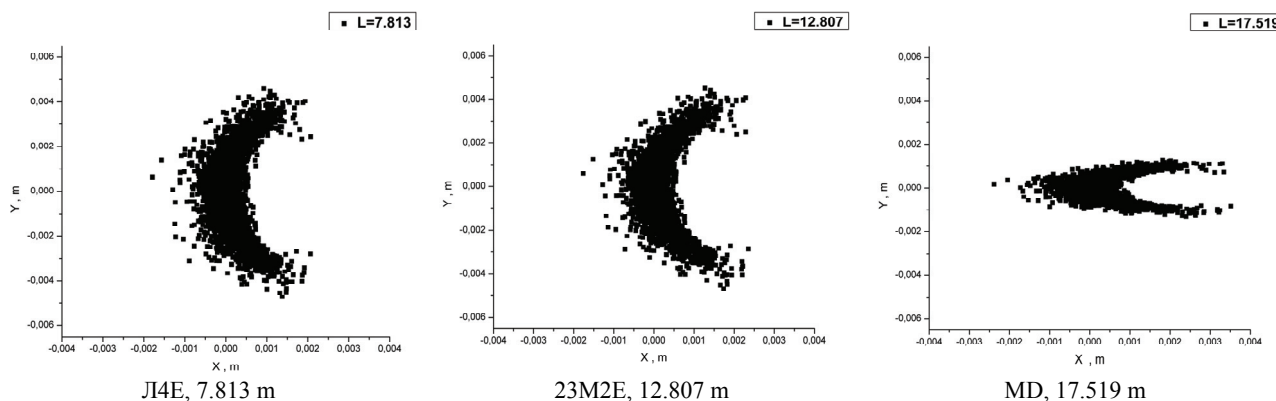

Fig. 16(Continued). Electron density distribution in the beam cross section along the trajectory of the EFEL channel

Shown in Fig. 16 in the same scale cross sections make it easy to trace the horizontal and vertical beam sizes are small enough in magnetic elements and will not result in a substantial loss in transit through the channel.

CONCLUSION

Output channels of electrons in the main experimental facilities differ both in length and structure magneto-optical system. This is primarily due to the placement of recirculator in the current targets hall linear accelerator LU 2000 [1-3]. Selected options in the beam transport channels provide minimal loss of electrons along the trajectory and the required size on the target. Common to all channels is a small effect of octupole components of the quadrupole lenses on the density distribution of the particles, the main contribution to the increase in size and density changes make sextupole components of the dipole magnets. Available on channels quadrupole lenses let you change the size of the beam on the target in a wide range and provide a change in the parameters of the beam when alter the experimental conditions and recirculator tuning.

REFERENCES

1. Arkatov Yu.M., Dovbnja A.N., Glamazdin A.V., Guk I.S., Kononenko S.G., van der Weil M., Botman J.I.M., Peev F.A., Tarasenko A.S. "SALO" project. – National Science Center Kharkov Institute of Physics Technology, Kharkiv, 2005. – 104 p.
2. Dovbnja A. N., Guk I. S., Kononenko S. G., Peev F. A., Tarasenko A. S., Botman J. I. M. Accelerating complex for basic researches in the nuclear physics. // Proceedings of the 2-nd International Conference "Current Problems in Nuclear Physics and Atomic Energy", June 9 to June 15, 2008, Kyiv, Ukraine, Kyiv, 2009. – P. 790-795.
3. Dovbnja A.N., Ganenko V.B., Guk I.S., Kononenko S.G., Tarasenko A.S. The electron beam lines from SALO recirculator to physical installation // The Journal of Kharkov National University, №784, physical series "Nuclei, Particles, Fields", Issue 4/36/. – 2007. - P. 74 - 78.
4. Khvastunov V.M., Denyak V.V. High-resolution spectrometer for "SALO"-project // Problems of atomic science and technology. Series "Nuclear Physics Investigations". 2001. - № 3 (55). – 2011. - P. 83-86.
5. Guk I.S., Kononenko S.G., Tapasenko A.S. Investigation of the effect of non-linear parameters of dipole and quadrupole magnets on the beam parameters in recirculator SALO // Problems of atomic science and technology. Series "Nuclear Physics Investigations" No 3 (79). – 2012. - P. 137-141.
6. Guk I.S., Kononenko S.G., Tapasenko A.S., Peev F.A. The basic summaries of working out of recirculator SALO magneto-optical system. // The Journal of Kharkov National University physical series "Nuclei, Particles, Fields". – 2012, №1017. - Issue 3/55/. - P. 107-116.
7. <http://mad.home.cern.ch/mad/>
8. Dovbnja A.N., Guk I.S., Kononenko S.G., Koval'ev G.G., Mytsykov A.Y., Peev F.A. Draft design of recirculator SALO magnetic system // The Journal of Kharkov National University, physical series "Nuclei, Particles, Fields". – 2007, №784. - Issue 4/36/. – P.3 – 14.
9. Boling Xi, Botman J.I.M., Timmermans C.J., Hagedoorn H.L.. Design study of storage ring EUTERPE // Nucl. Instr. and Meth. – 1992. – Vol.B68. - P. 101.
10. Guk I.S., Dovbnja A.N., Kononenko S.G., Peev F.A., Tarasenko A.S. Aberrations of Magneto-optical System of SALO Recirculator // Physics of Particles and Nuclei Letters. – 2010. - Vol. 7, №7. –P. 1–4.



Guk Ivan Semenovich, Ph.D., senior scientific researcher NSC KIPT

Scientific interests: framing of large accelerating complexes, beam dynamics in accelerators, synchrotron radiation, powerful sources of neutrons and electrons. The author and the co-author more than 120 papers and 2 books



Kononenko Stanislav Grigor'evich, senior scientific researcher NSC KIPT
Scientific interests: beam dynamics in accelerators, powerful sources of neutrons and electrons
The author and the co-author more than 110 papers and 2 books



Peev Fedor Andreevich, scientific researcher NSC KIPT
Scientific interests: framing of large accelerating complexes, powerful sources of neutrons and electrons
The author and the co-author more than 90 papers and 2 books



Tarasenko Alexander Sergeevich, senior scientific researcher NSC KIPT
Scientific interests: beam dynamics in accelerators, synchrotron radiation, powerful sources of neutrons and electrons
The author and the co-author more than 110 papers and 2 books